

REV.	DESCRIPTION	NAME	DATE
A	NEWS ISSUE		

Note:

1. Material:
 - 1.1 Housing: LCP
 - 1.2 Contact: C7025, t=0.20mm
AU plating 3U" on contact area.
50 U" Tin plating on solder area.
 - 1.3 Shell: Zinc Alloy.
50U" NI or Sn plating over all.
2. ELECTRICAL:
 - 2-1: CURRENT RATING:
VBUS AND GND CONTACTS RATED AT 1.5A
PARALLELED FOR A TOTAL OF 3A;
 - 2-2: INITIAL CONTACT RESISTANCE : 40 MEGOHMS
 - 2-3: DIELECTRIC WITHSTANDING VOLTAGE:
100V AC MIN;
- 3: MECHANICAL CHARACTERISTICS:
 - 3-1: MATING FORCE: 5~20N
 - 3-2: UNMATING FORCE: 8~20N (INITIAL),
6~20N (AFTER 10000 CYCLES)
 - 3-3: FREQUENCY: 200 ± 50 CYCLES / HOUR, 5000 CYCLES
 - 3-4: OPERATING TEMPERATURE ; -40° ~ 80° .
- 4: WATERPROOF: IPX7.

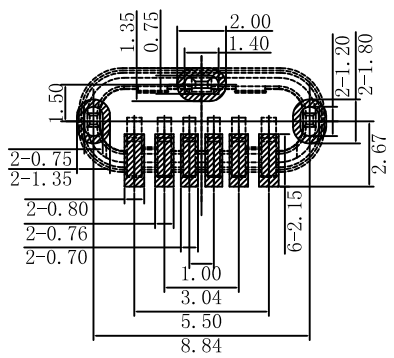
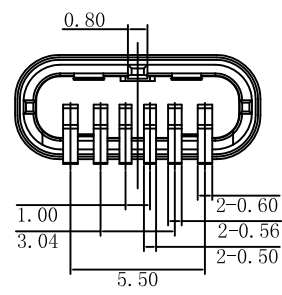
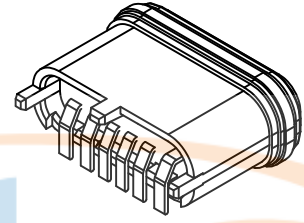
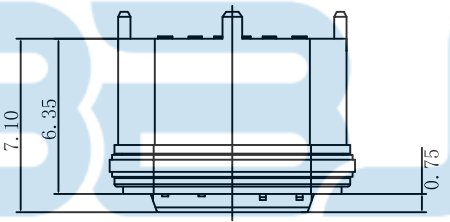
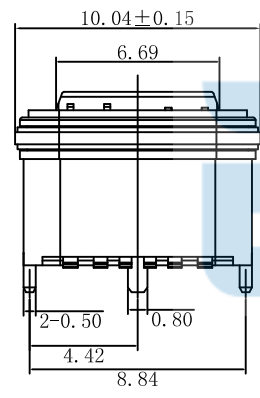

USB TYPE-C PIN ASSIGNMENTS

PIN NUMBER	A1	A2	A3	A4	A5	A6	A7	A8	A9	A10	A11	A12
SIGNAL NAME					CC1				VBUS			GND
PIN NUMBER	B12	B11	B10	B9	B8	B7	B6	B5	B4	B3	B2	B1
SIGNAL NAME	GND			VBUS				CC2				

TOLERANCE UNSPECIFIED
 X. ±0.50 X.° ± 2°
 .X ±0.30 .X° ± 1°
 .XX ±0.10 .XX° ± 0.5°
 .XXX ±0.05

BBJconn Technology Co., Ltd.
深圳市步步精科技有限公司

TITLE: TYPE-C 6P 防水母座 180度 H=6.35 舌片外漏0.75 立式贴片 SMT 缩口式 IPX7 粉末冶金

DRAWN/ DATE	设计 TSP	SIZE: A4	UNIT: MM.	PART. NO:	UC.01.63-1W-0007
CHECKED/ DATE	审核 LYX	SCALE: 1:1	PROJECTION	REV.:	版本
APPROVED/ DATE	核准 LJP	DWG. PATH	0482-1	SHEET:	页码

RECOMMEND P.C.B LAYOUT (COMPONENT SIDE)
 TOLERANCE FOR PCB LAYOUT IS ± 0.05



REV.	DESCRIPTION	NAME	DATE
A	NEWS ISSUE		

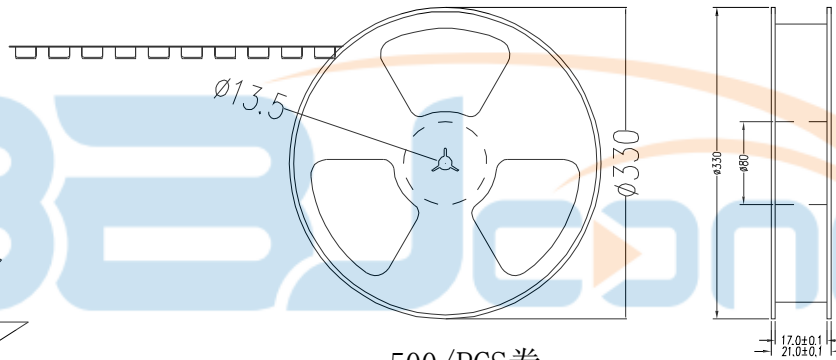
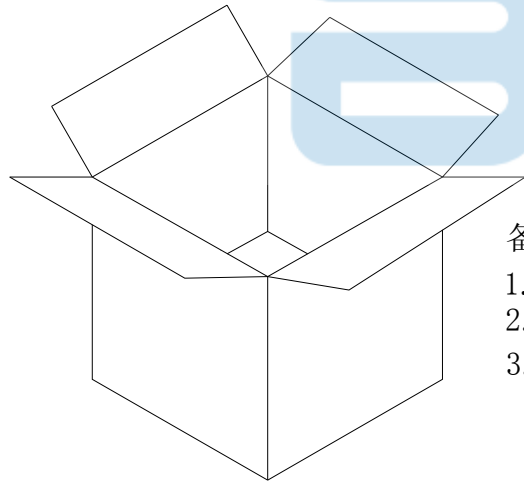
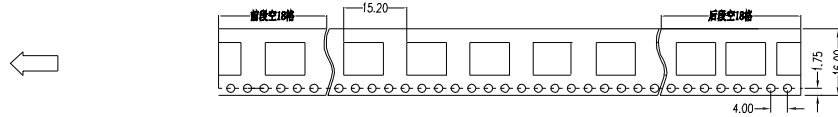
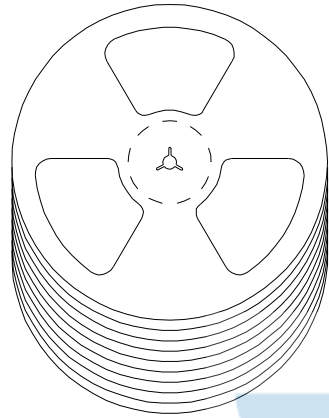

500/PCS卷

备注:

1. 包装数量: 500/PCS/卷, 10卷/箱或15卷/箱。
2. 包装袋长度: 每卷前后各空10-20个空格, 中间包装。
3. 材质:
 - 载体: 聚丙烯 (PS), 阻抗 $10^{6-9} \Omega$
 - 上带: 聚乙烯 (PET), 阻抗 $10^{6-11} \Omega$
 - 卷盘: 聚苯乙烯。

纸箱规格: 345*345*23MM
纸箱规格: 345*345*35MM



TOLERANCE UNSPECIFIED		深圳市步步精科技有限公司 TITLE: TYPE-C 6P 防水母座 180度 H=6.35 舌片外漏0.75 立式贴片 SMT 缩口式 IPX7 粉末冶金					
.0	±0.35						
.00	±0.25	DRAWN/ DATE	设计 TSP	SIZE: A4	UNIT: MM.	PART. NO:	UC.01.63-1W-0007
.000	±0.15	CHECKED/ DATE	审核 LYX	SCALE: 1:1	PROJECTION	REV.:	版本
X.°	±2.00°	APPROVED/ DATE	核准 LJP	DWG. PATH	0482-1	SHEET:	页码
CUSTOMER DRAWING							