

REV.	ECN NO	CONTENT	DATE	ENGINEER
AO		Initial release	/	TSP

- Notes:
- Coplanarity : 0.08Max before IR, 0.10Max after IR.
 - Tongue position : 0.08Max before reflow, 0.12Max after reflow.
 - Packaging type: carrier tape.
 - Dimension marked ★ should be checked by QC and process.
Marked ▽ Should also check the CPK (CPK>=1.33) data.
 - No burrs are allowed on the contact area and solder tail area,
the maximum allowed stamping burrs is 0.05mm unless otherwise specified.

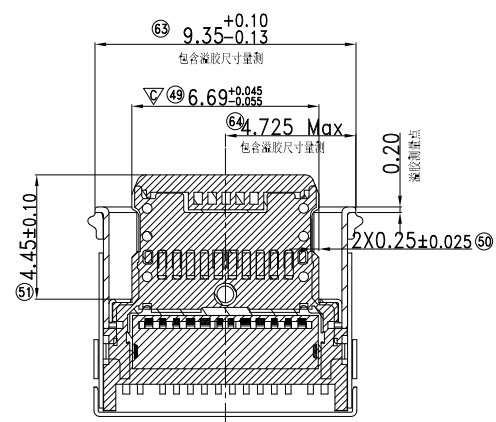
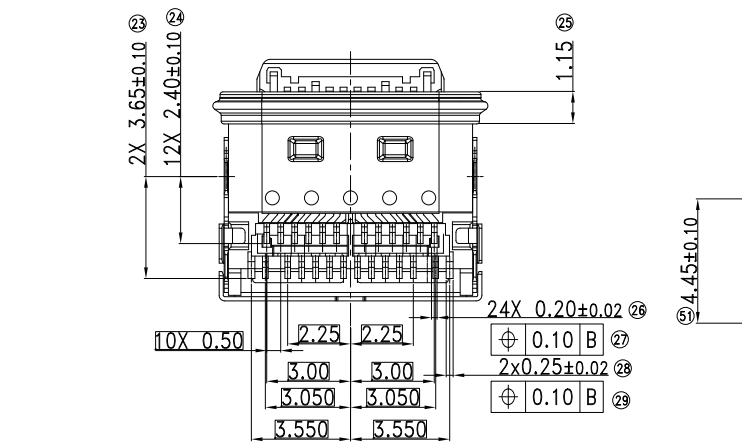
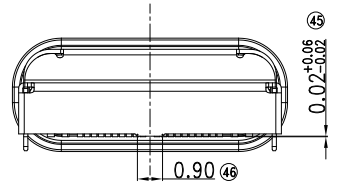
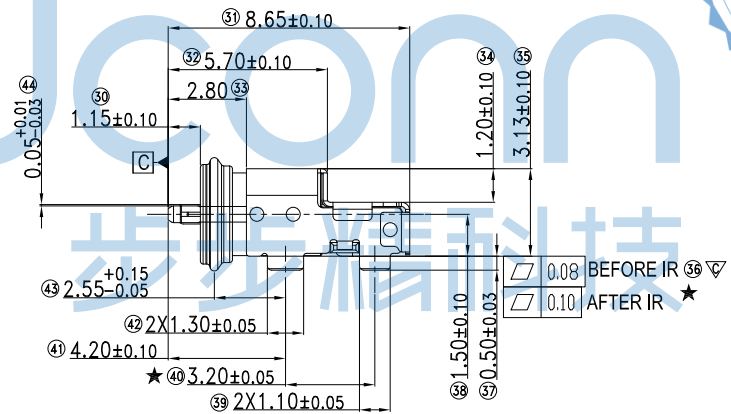
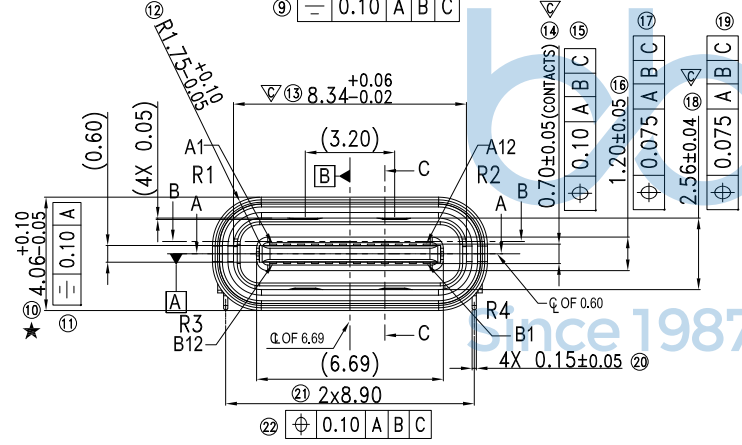
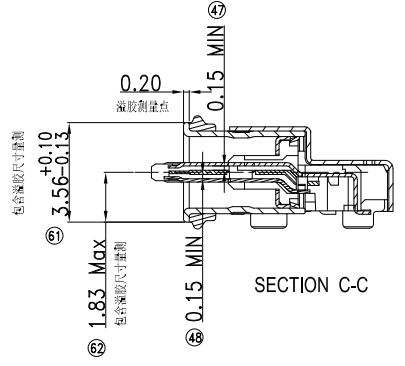
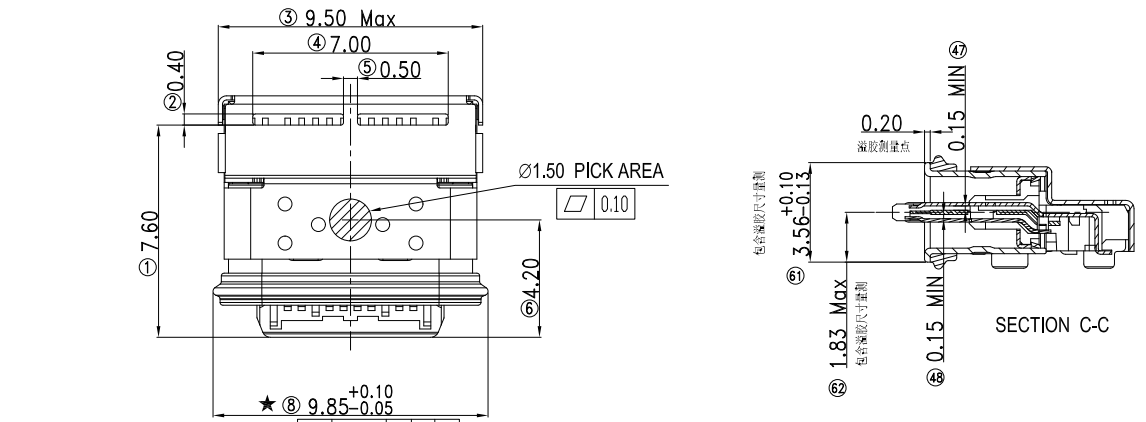

ITEM	DESCRIPTION	Q'TY	MATERIAL	FINISH
8	LIM	1	CHN-IMS-50-A/B	BLACK
7	SMALL SHELL	1	SUS304-1/2H	NICKEL: 50U" MIN
6	MAIN SHELL	1	SUS304-1/2H	NICKEL: 50U" MIN
5	SUB-SHELL	1	SUS304-H	SOLDER NICKEL: 50U" MIN
4	TOP TERMINAL	1	NKE012-EH	MATING SIDE:30u" AU MIN; INCLUDING SIDE AND BOTTOM SIDE: GOLD FLASH; SOLDER TAIL:GOLD FLASH, 50u" NICKEL OVERALL.
3	BOTTOM TERMINAL	1	NKE012-EH	MATING SIDE:30u" AU MIN; INCLUDING SIDE AND BOTTOM SIDE: GOLD FLASH; SOLDER TAIL:GOLD FLASH, 50u" NICKEL OVERALL.
2	MID PLATE	1	SUS301-1/4H	SOLDER NICKEL: 50U" MIN
1	MAIN HOUSING	1	PA46 HFX31S	BLACK

THIS DOCUMENT IS THE SOLE PROPERTY OF BBJconn Technology Co., Ltd. Corporation AND SHOULD NOT BE USED IN WHOLE OR IN PART WITHOUT PRIOR WRITTEN PERMISSION.

PDWG.NO: 0523-1

DR. TSP

APPD. JM_Zheng

CHKD. LYX

APPROVED

深圳市步步精科技有限公司

NAME: TYPE-C 24P 防水母座 双壳 板上四脚插 端子双排SMT L=7.50 CH=1.50 舌片外漏1.15 IP68 编带

PJ. NO.: 126-221-240003-U9G

SIZE: A4 DRW NO.:

FINISH: SEE NOTES MAT'L.: SEE NOTES

SCALE: N/A REV.: AO UNIT: mm PAGE: 1/2

REV.	ECN NO	CONTENT	DATE	ENGINEER
A0		Initial release	/	TSP

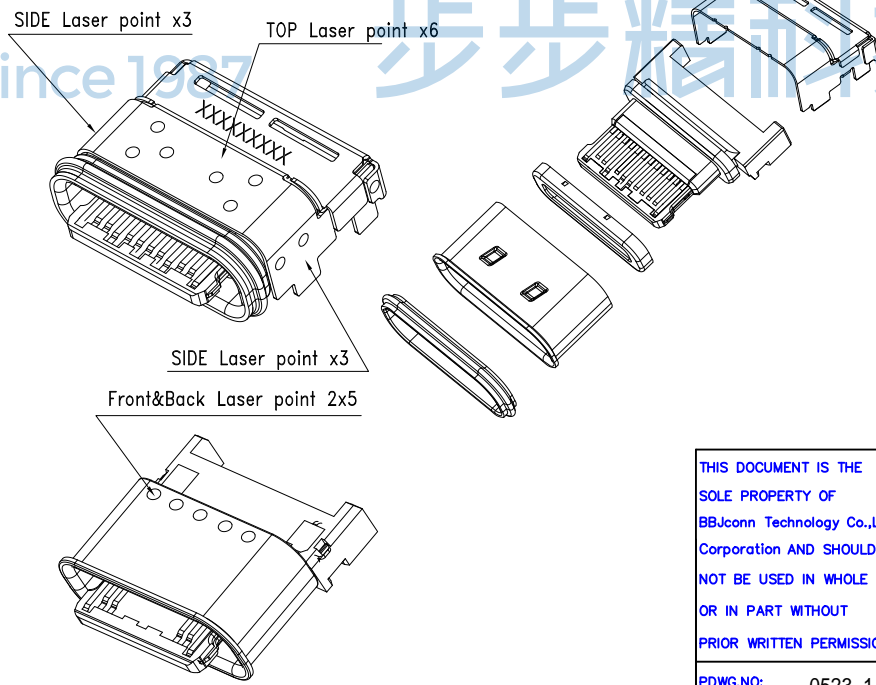
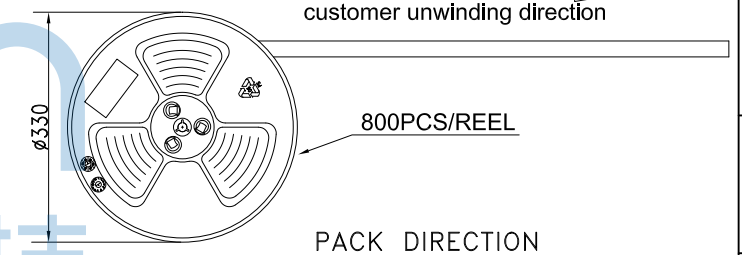
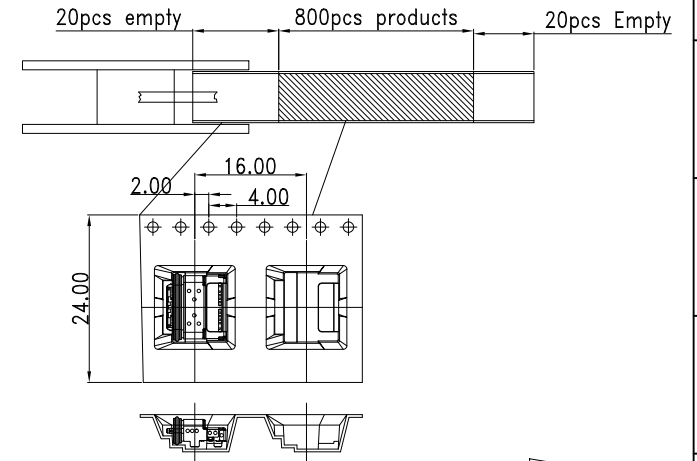
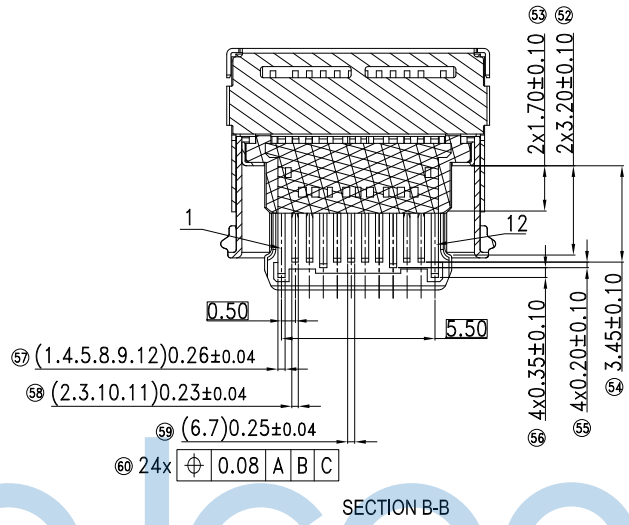
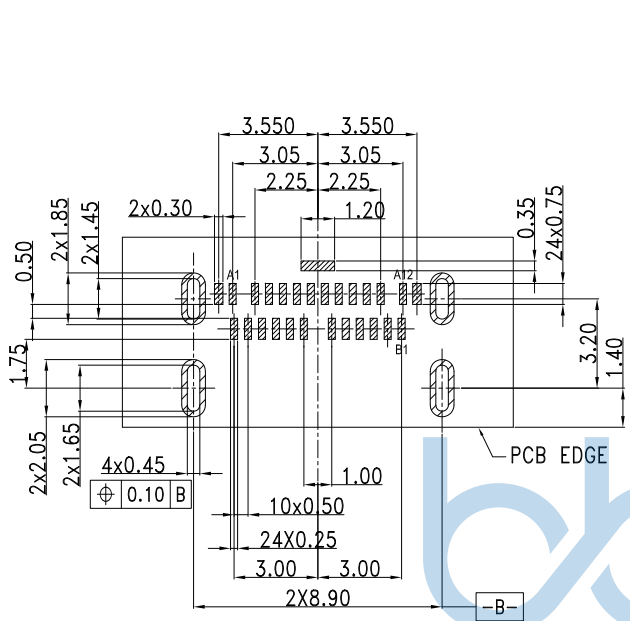

Pin No	Signal Name	Mating Sequence	Pin No	Signal Name	Mating Sequence
A1	GND	First	B12	GND	First
A2	TX1+	Second	B11	RX1+	Second
A3	TX1-	Second	B10	RX1-	Second
A4	Vbus	First	B9	Vbus	First
A5	CC1	Second	B8	SBU2	Second
A6	D+	Second	B7	D-	Second
A7	D-	Second	B6	D+	Second
A8	SBU1	Second	B5	CC2	Second
A9	Vbus	First	B4	Vbus	First
A10	RX2-	Second	B3	TX2-	Second
A11	RX2+	Second	B2	TX2+	Second
A12	GND	First	B1	GND	First
SHFLL	GND		SHFLL	GND	



THIS DOCUMENT IS THE SOLE PROPERTY OF BBJconn Technology Co., Ltd. Corporation AND SHOULD NOT BE USED IN WHOLE OR IN PART WITHOUT PRIOR WRITTEN PERMISSION.		深圳市步步精科技有限公司 .X: ±0.38 .XX: ±0.25 .XXX: ±0.13 X*: ±3* .X*: ±2* .XX*: ±1*		NAME: TYPE-C 24P 防水母座 双壳 板上四脚插 端子双排SMT L=7.50 CH=1.50 舌片外漏1.15 IP68 编带 APPD. JM_Zheng CHKD. LYX DR. TSP PDWG.NO: 0523-1		PJ. NO.: 126-221-240003-U9G SIZE: A4 DRW NO.: FINISH: SEE NOTES MAT'L.: SEE NOTES SCALE: N/A REV.: A0 UNIT: mm PAGE: 2/2	
---	--	---	--	---	--	---	--