

REV	ECN NO	CONTENT	DATE	ENGINEER
A0		INITIAL RELEASE	/	SGF

NOTE:  
 1.MATERIAL SPECIFICATION:See Table;  
 2.PLATING SPECIFICATION:See Table;  
 3.ELECTRICAL CHARACTERISTICS:  
 3-1. VOLTAGE&CURRENT RATING:DC 30V MAX RATED CURRENT:1.5 A  
 3-2. CONTACT RESISTANCE: 30mΩ MAX.  
 3-3. INSULATION RESISTANCE: 1000MΩ MIN.  
 3-4. DIELECTRIC WITHSTAND: 750V AC for 1 MINUTE  
 3-5. OPERATING TEMPERATURE: -55°C~+85°C  
 3-6. Salt Spray 8H Min  
 4.MECHANICAL CHARACTERISTICS:  
 4-1. INSERT FORCE: 35N MAX.  
 4-2. WITHDRAW FORCE:10N MIN INITIAL.  
 5.LIFE TEST: 1500 CYCLES  
 6.OTHER GENERAL SPEC. TO REFER "USB 3.0&USB2.0 SERIES SPEC"  
 7.Packaging type:Blister box.

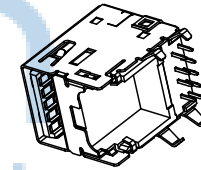

SCALE 2:1

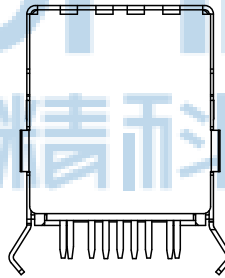
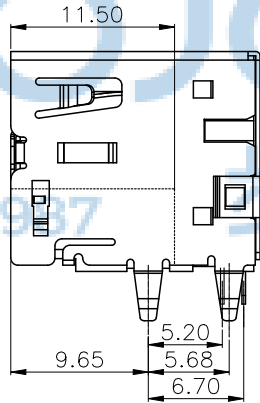
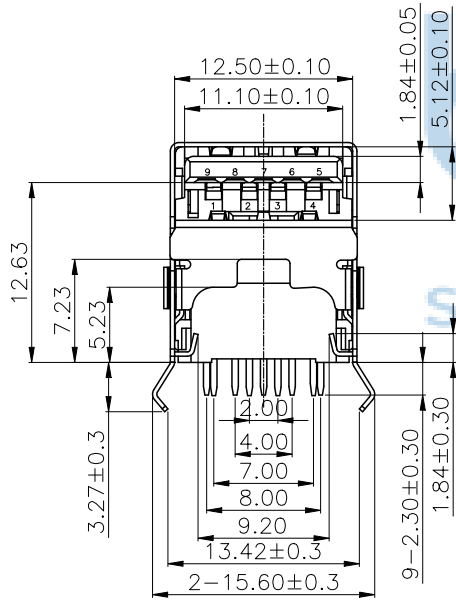
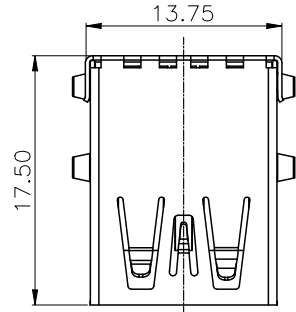
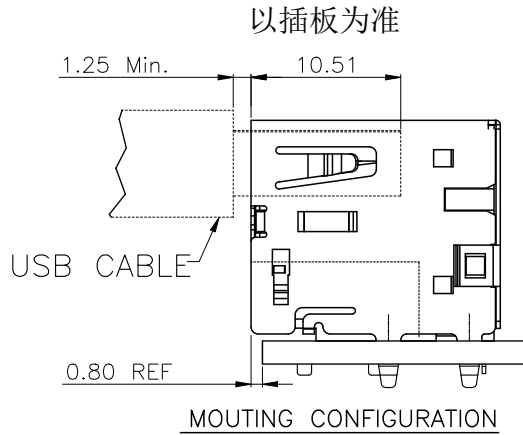
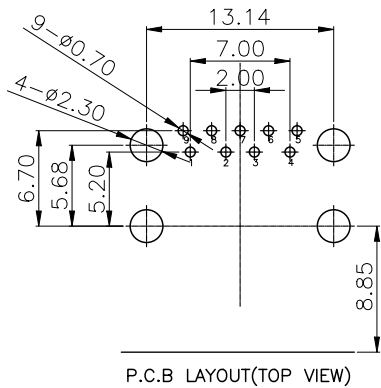

Item	Title	Material	Dispose	Q'TY
1	Shell	SUS430	NI 30U" MIN	1PCS
2	Mid Plate	SUS430	NI 50u" min	1PCS
3	Contact 4pin	C5191	Au Plated on contact area	1SET
4	Contact 5pin	C2680	Nickel underplating over all Tin Plated on solder area	1SET
5	Housing	PA9T	BLACK UL94-V0	1PCS
6	Cover	PA9T	BLACK UL94-V0	1PCS

THIS DOCUMENT IS THE  
 SOLE PROPERTY OF  
 BBJconn Technology Co.,Ltd.  
 Corporation AND SHOULD  
 NOT BE USED IN WHOLE  
 PRIOR WRITTEN PERMISSION.

PDWG NO: 0900-1

<b>BBJconn</b> 深圳市步步精科技有限公司		NAME: USB 3.0 A母 单层 垫高款 90度 DIP 镀金GF 四脚弯插 平口 不锈钢外壳 PA9T黑胶 L=17.50 H=15.44 盒装	
APPD	JM_Zheng	PJ NO: SIZE:A4 DRW NO:	
CHKD	LYX		FINISH:SEE NOTES
DR	SGF	SCALE:N/A	REV:A0 UNIT:mm PAGE:1/2

产品

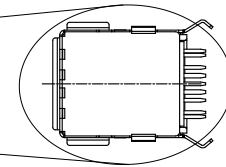
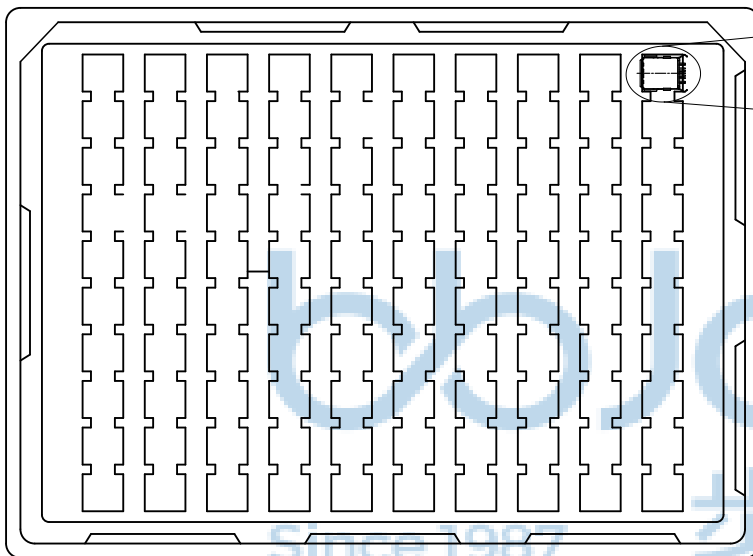

包装说明:

1. 数量: 一盘=100Pcs
2. 每10盘1000PCS叠成一叠, 每一叠配一个上盖, 在每叠产品左上角帖标签, 每叠上下各放一纸板并用透明胶缠紧;
3. 每两叠并排放入纸箱, 每箱2000PCS, 包装过程中注意不可碰伤刮伤产品。
4. 适用料号: 加高U3及特别要求双层USB3.0, 双层USB 2.0
5. 外箱材质A=A.

BOX DIMENSIONS:  
470\*320\*325

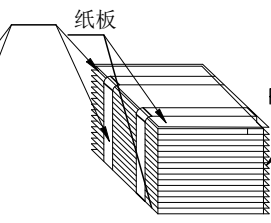
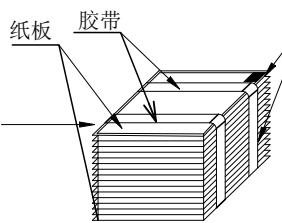
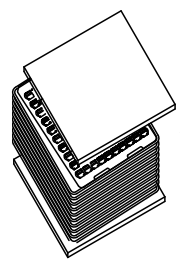

PS TRAY盘

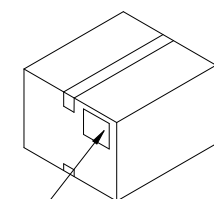
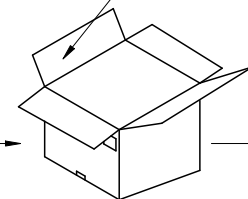

Where the label is affixed

包装示图



100	20	2000 PCS	-- KG	-- KG
PCS/ 盘	盘/ CARTON	QUANTITY	GROSS WEIGHT	NET WEIGHT

THIS DOCUMENT IS THE SOLE PROPERTY OF BBJconn Technology Co.,Ltd. Corporation AND SHOULD NOT BE USED IN WHOLE PRIOR WRITTEN PERMISSION.		<b>深圳市步步精科技有限公司</b>	
PDWG NO: 0900-1		NAME: USB 3.0 A母 单层 垫高款 90度 DIP 镀金GF 四脚弯插 平口 不锈钢外壳 PA9T黑胶 L=17.50 H=15.44 盒装 .X: ±0.38 X': ±3" .XX: ±0.25 .X': ±2" .XXX: ±0.13 .XX': ±1"	
APPD	JM_Zheng	PJ NO: 	
CHKD	LYX	SIZE:A4 DRW NO:	
DR	SGF	FINISH:SEE NOTES MAT'L:SEE NOTES SCALE:N/A REV:AO UNIT:mm PAGE:2/2	