

REV.	ECN NO	CONTENT	DATE	ENGINEER
A0		Initial release	/	TSP

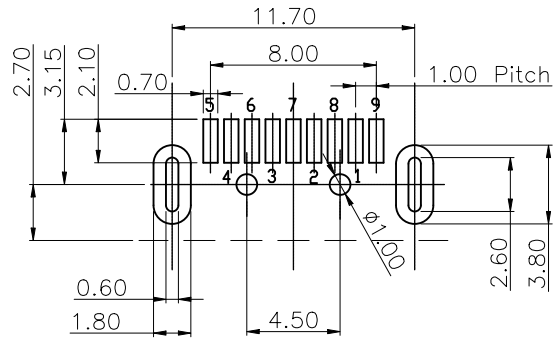

RECOMMENDED P.C.B LAYOUT

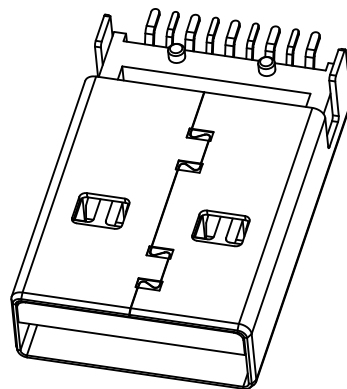
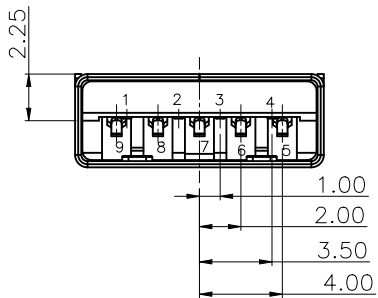
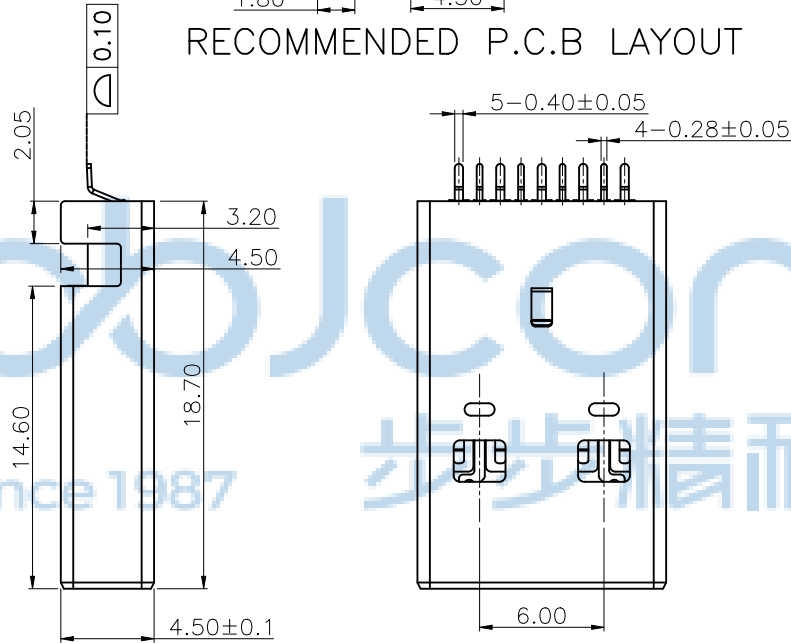
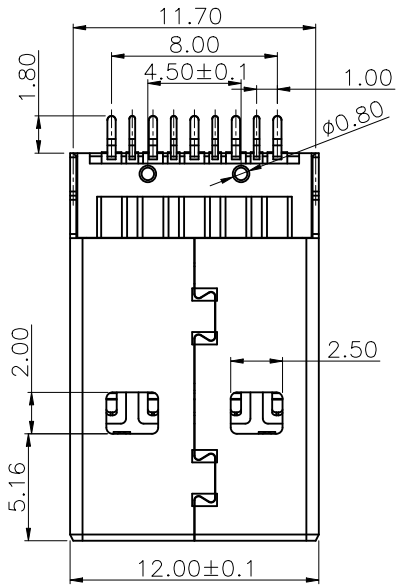

- NoNOTE:
- MATERIAL:
 - INSULATOR:LCP UL 94V-0
 - CONTACT:Copper alloy (T=0.20mm) PLATED Ni50u", Sn80u"Au1~30u"
 - SHELL: SPCC (T=0.30mm) PLATED Ni50u" MIN.
 - ELECTRICAL CHARACTERISTICS:
 - CONTACT RESISTANCE: 30mΩ MAXIMUM
 - CONTACT CURRENT RATING: 1.5 AMPERES
 - DIELECTRIC WITHSTANDING VOLTAGE: 100 V AC R. M. S.
 - INSULATION RESISTANCE 100 MEGOHMS MIN
 - OPERATING TEMPERATURE: -40° C ~ 85° C
 - MECHANICAL CHARACTERISTICS:
 - MATING FORCE: 3.57kgf MAX
 - UNMATED FORCE: 1.02kgf MIN INITIAL/0.82kgf MIN
 - DURABILITY: 1,500 CYCLES



Pin NUMBER	SIGNAL NAME
1	VBUS
2	D-
3	D+
4	GND
5	StdA_SSRX-
6	StdA_SSRX+
7	GND_DRAIN
8	StdA_SSTX-
9	StdA_SSTX+
Shell	Shield

THIS DOCUMENT IS THE SOLE PROPERTY OF BBJconn Technology Co., Ltd. Corporation AND SHOULD NOT BE USED IN WHOLE OR IN PART WITHOUT PRIOR WRITTEN PERMISSION.

PDWG.NO: 0536-1

深圳市步步精科技有限公司

NAME: USB 3.0 公头 90度 L=18.70 沉板1.25 直脚 带柱 平口 LCP蓝胶 铁壳 端子SMT 端子镀金1u 编带

APPD. JM_Zheng

CHKD. LYX

DR. TSP

PJ. NO.: 127-171-090003-P2G

SIZE: A4 DRW NO.:

FINISH: SEE NOTES MAT'L.: SEE NOTES

SCALE: N/A REV.: A0 UNIT: mm PAGE: 1/2

REV.	ECN NO	CONTENT	DATE	ENGINEER
A0		Initial release	/	TSP

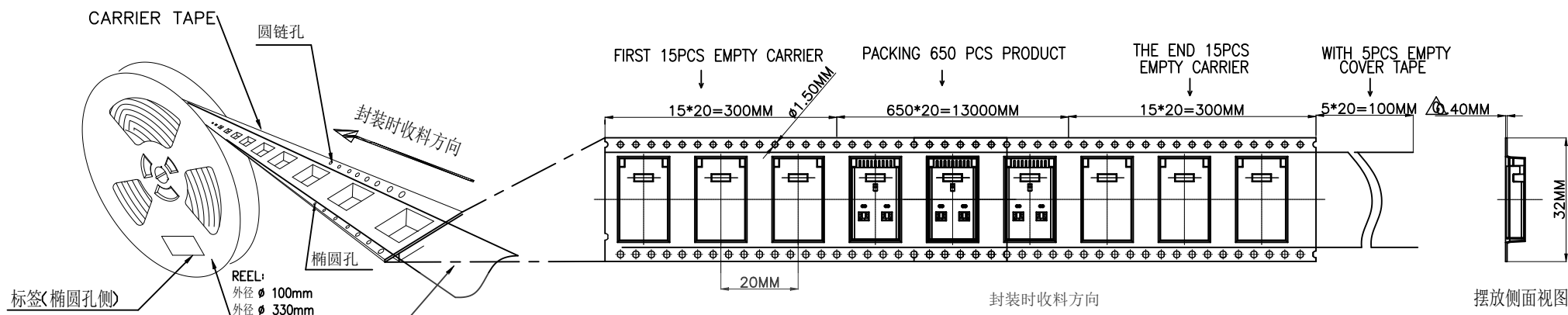

① 每卷650PCS.

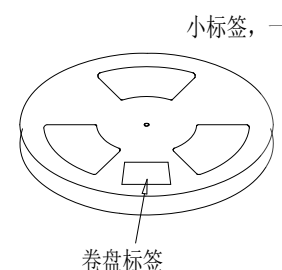

② 在外圈包上1PCS保护带, 贴上卷盘标签

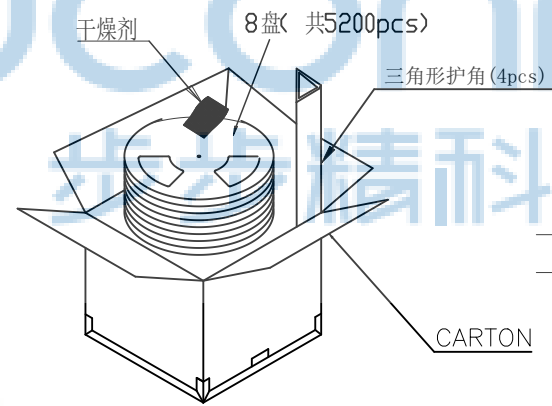

③ 每袋(8盘)装一箱, 即5200PCS/箱, 四周放4PCS三角形护角
如果为尾数箱, 则空间处需加装填充物填实。

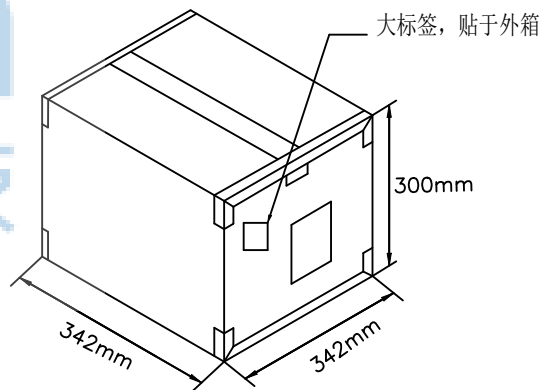

④ 透明胶带封好箱后依图示粘贴各类标签

Notes:

1. 每卷650PCS, 前后各空15PCS. 尾部用美纹胶纸封住.
2. 然后再卷一圈保护带, 保护带最后需留100MM, 用皱纹胶纸将其封住.
3. 每个卷盘贴一张小标签 (按要求填写).
4. 每8卷盘(5200PCS)装入一箱, 然后放入1个干燥剂;
5. 各类标签依照图示粘贴在纸箱侧上方.
6. 产品单重:1.87g, 整箱净重:9.5Kg, 整箱毛重:12Kg.



THIS DOCUMENT IS THE SOLE PROPERTY OF BBJconn Technology Co., Ltd. Corporation AND SHOULD NOT BE USED IN WHOLE OR IN PART WITHOUT PRIOR WRITTEN PERMISSION.		深圳市步步精科技有限公司	
PDWG.NO: 0536-1	DR. TSP	NAME: USB 3.0 公头 90度 L=18.70 沉板1.25 直脚 带柱 平口 LCP蓝胶 铁壳 端子SMT 端子镀金1u 编带	PJ. NO.: 127-171-090003-P2G
APPD. JM_Zheng	CHKD. LYX	SIZE: A4	DRW NO.:
		FINISH: SEE NOTES	MAT'L.: SEE NOTES
		SCALE: N/A	REV.: A0
		UNIT: mm	PAGE: 2/2