

REV.	ECN NO.	CONTENT	DATE	ENGINEER
AO		Initial release	/	TSP

NOTE:

1. MATERIAL:
 - 1.1 INSULATOR:LCP/PBT UL 94V-0
 - 1.2 CONTACT:BRONZE C5191
 - 1.3 SHELL:BRASS C2680/SPCC
2. ELECTRICAL CHARACTERISTICS:
 - 2.1 CONTACT RESISTANCE:30mΩ MAXIMUM
 - 2.2 CONTACT CURRENT RATING:1.5A
 - 2.3 DIELECTRIC WITHSTANDING VOLTAGE:100 V AC R. M. S.
 - 2.4 INSULATION RESISTANCE 100 MEGOHMS MIN
 - 2.5 OPERATING TEMPERATURE:-40° C ~ 85° C
- 3 MECHANICAL CHARACTERISTICS:
 - 3.1 MATING FORCE:3.57kgf MAX
 - 3.2 UNMATED FORCE:1.02kgf MIN AFTER TEST
 - 3.3 DURABILITY MANDATORY:1200 CYCLES
4. PLATING
 - 4.1 TERMINAL:
 - 50u" MIN NICKEL ALL OVER
 - 80u"MIN Tin ON SOLDER AREA
 - (1~30)u"Au ON CONTACT AREA
 - 4.2 SHELL:100u"MIN. NICEL ALL OVER

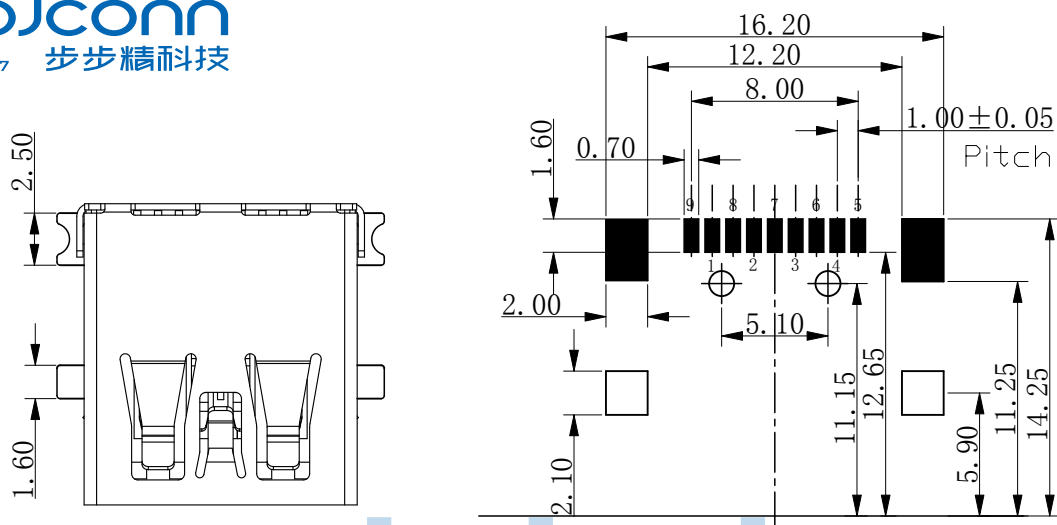

PCB EDGE
RECOMMENDED PCB LAYOUT

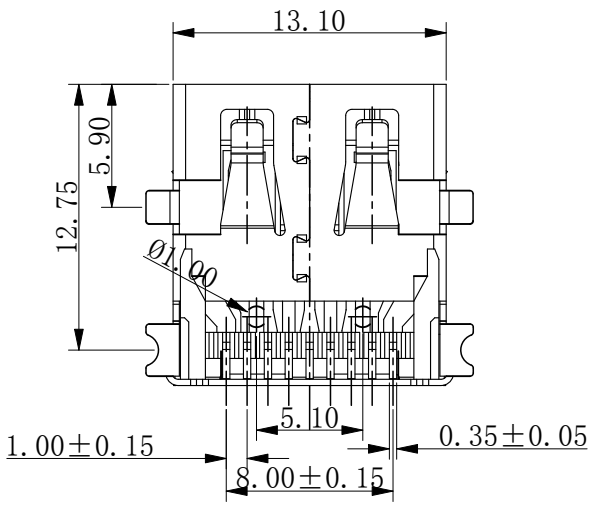
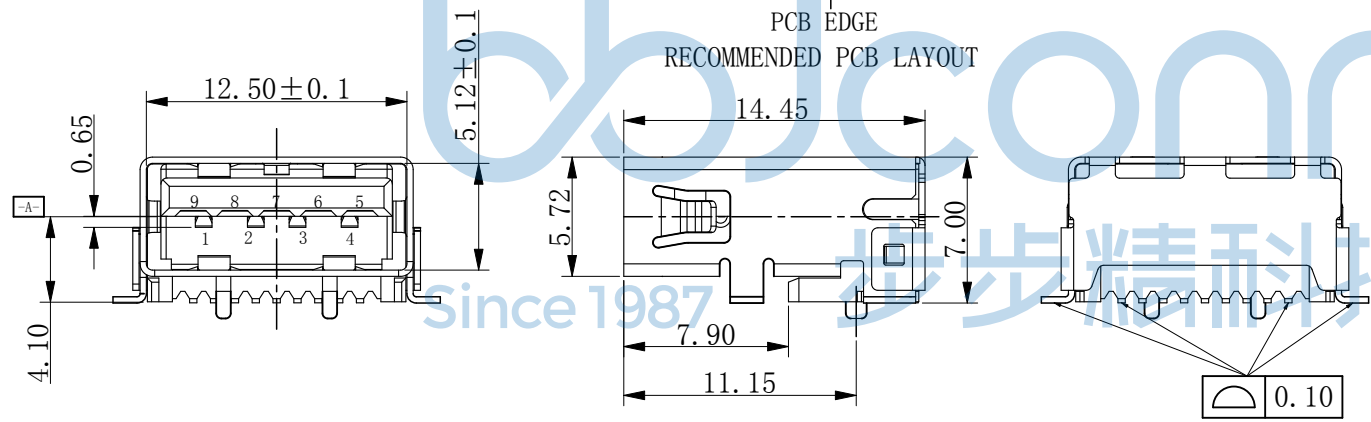

THIS DOCUMENT IS THE SOLE PROPERTY OF BBJconn Technology Co.,Ltd Corporation AND SHOULD NOT BE USED IN WHOLE OR IN PART WITHOUT PRIOR WRITTEN PERMISSION.		深圳市步步精科技有限公司	
PDWG.NO: 0536-1	APPD. JM_Zheng	NAME: USB 3.0 AF 90度 L=14.45 全贴 带柱 端子SMT 平口 LCP蓝胶 铜壳 吸塑盒	
CHKD. LYX	DR. TSP	PJ. NO.: UB.03.22-32-W002	
		SIZE: A4 DRW NO.:	
		FINISH: SEE NOTES MAT'L.: SEE NOTES	
		SCALE: N/A	REV.: AO UNIT: mm PAGE: 1/2

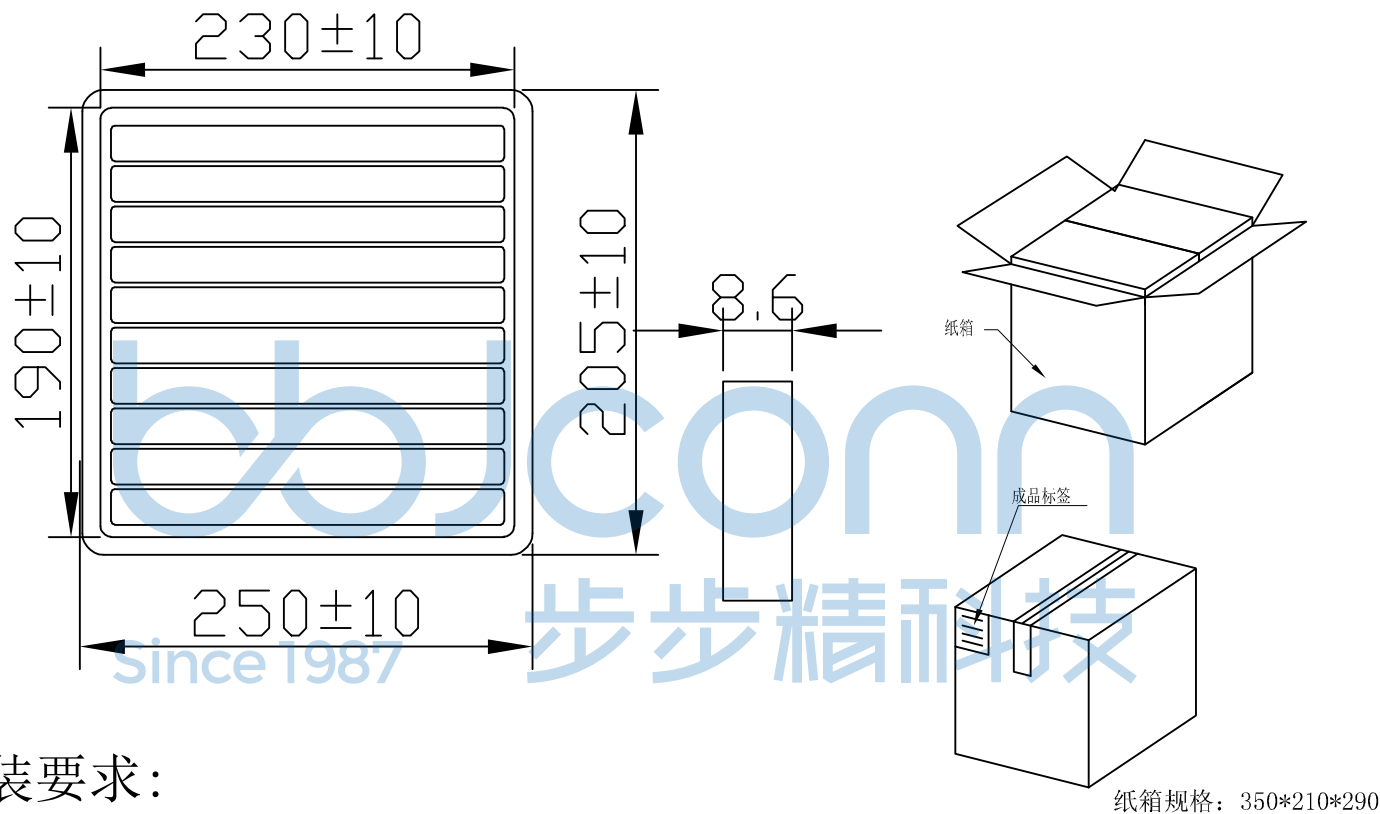

1. 包装要求:

- 1.1 每盒吸塑盒包装100pcs;
- 1.2 每20盘放一箱, 共计2000PCS;
- 1.3 纸箱外贴上标签。

THIS DOCUMENT IS THE SOLE PROPERTY OF BBJconn Technology Co.,Ltd. Corporation AND SHOULD NOT BE USED IN WHOLE OR IN PART WITHOUT PRIOR WRITTEN PERMISSION.		深圳市步步精科技有限公司	
PDWG.NO: 0536-1		.X: ±0.38 .XX: ±0.25 .XXX: ±0.13	X': ±3" .X': ±2" .XX': ±1"
APPD.	JM_Zheng	NAME: USB 3.0 AF 90度 L=14.45 全贴 带柱 端子SMT 平口 LCP蓝胶 铜壳 吸塑盒	
CHKD.	LYX	PJ. NO.: UB.03.22-32-W002	
DR.	TSP	SIZE: A4 DRW NO.:	
		FINISH: SEE NOTES	MAT'L.: SEE NOTES
		SCALE: N/A	REV.: A0
		UNIT: mm	PAGE: 2/2