

REV.	ECN NO.	CONTENT	DATE	ENGINEER
A0				

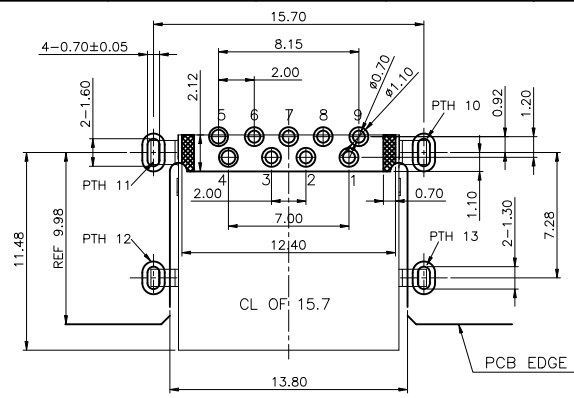

TOLERANCE: ±0.05, THICKNESS: 1.0~1.2mm
RECOMMENDED PCB LAYOUT
(TOP VIEW)
KEEP OUT AREA

- NOTE:
- MATERIAL:
 - INSULATOR: HIGH TEMPERATURE PLASTIC UL 94 V-0; Blue
 - CONTACT: COPPER ALLOY C5191(T=0.20mm)
 - SHELL: SUS201(T=0.30mm)
 - ELECTRICAL CHARACTERISTICS:
 - CONTACT RESISTANCE: 30mΩ Max
 - CONTACT CURRENT RATING: 1.5A
 - DIELECTRIC WITHSTANDING VOLTAGE: 100 V R.M.S.
 - INSULATION RESISTANCE 100 MEGOHMS M
 - OPERATING TEMPERATURE: -55°C ~ 85°C
 - RATE VOLTAGE: 30V DC
 - MECHANICAL CHARACTERISTICS:
 - MATING FORCE: 1.0~2.5 Kgf Min INITIAL; 0.8 Kgf Min AFTERT
 - UNMATED FORCE: 2.0 Kgf Max
 - DURABILITY: 5,000 CYCLES
 - PLATING
 - TERMINAL CONTACT: GOLD PLATING ALL OVER
50u" MIN NICKEL AND 80u" MIN Matte Tin
NICKEL IN SOLDER AREA (SEE TAB)
 - SHELL: 50u" MIN. NICKEL ALL OVER

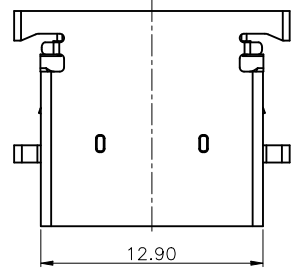
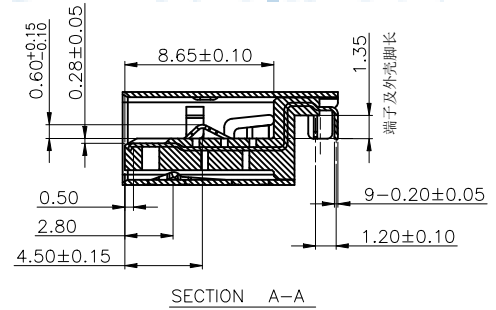
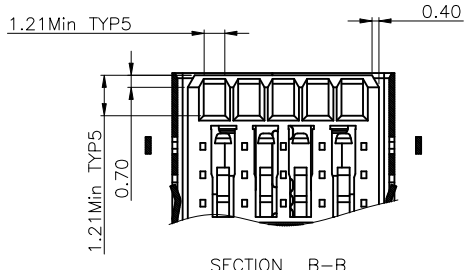
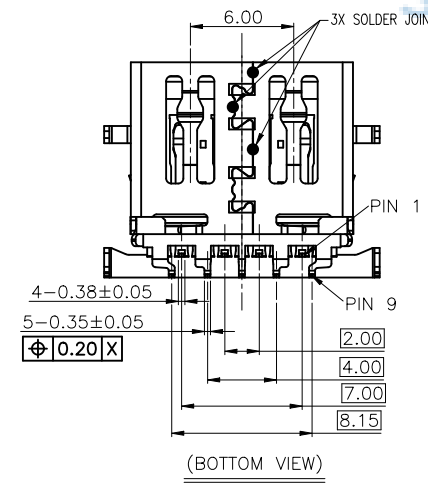
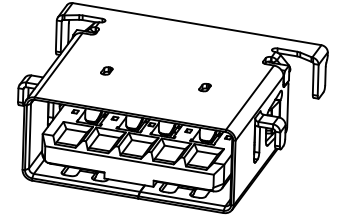
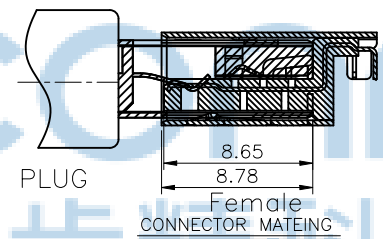
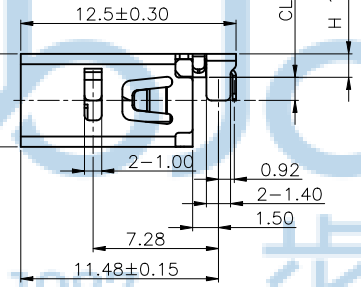
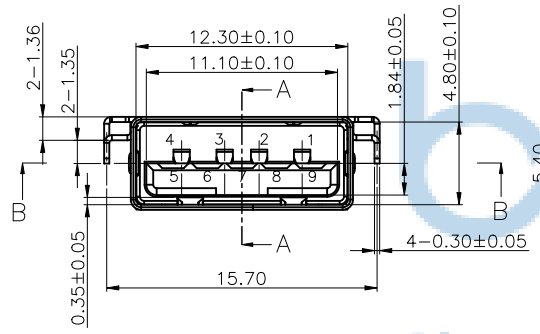

Pin NUMBER	SIGNAL NAME	THIS DOCUMENT IS THE SOLE PROPERTY OF BBJconn Technology Co., Ltd. Corporation AND SHOULD NOT BE USED IN WHOLE OR IN PART WITHOUT PRIOR WRITTEN PERMISSION.
1	VBUS	
2	D-	
3	D+	
4	GND	
5	Std_A_SSRX-	
6	Std_A_SSRX+	
7	GND_DRAIN	
8	Std_A_SSTX-	
9	Std_A_SSTX+	
Shell	Shield	

深圳市步步精科技有限公司

NAME: USB 3.0 AF 90° 反向沉板 沉板4.04 L=12.5 CH=-1.34 直脚 1.35 短款平口 锡脚长1.35 DIP LCP蓝色 不锈钢壳 带焊点

APPD. JM_Zheng

CHKD. TSP

DR. LYX

FINISH: SEE NOTES MAT'L.: SEE NOTES

SCALE: N/A REV.: A0 UNIT: mm PAGE: 1/1



REV.	ECN NO	CONTENT	DATE	ENGINEER
A0				

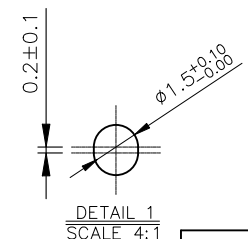
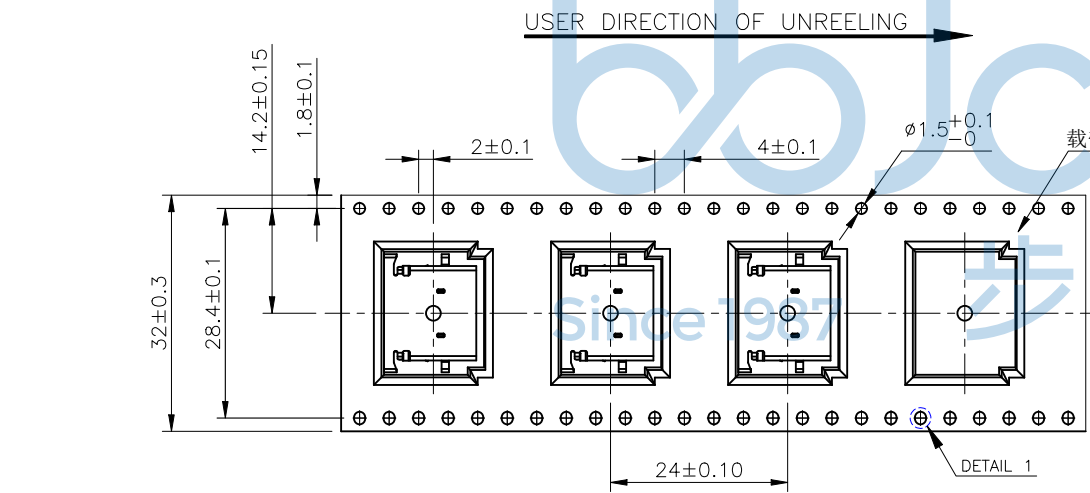
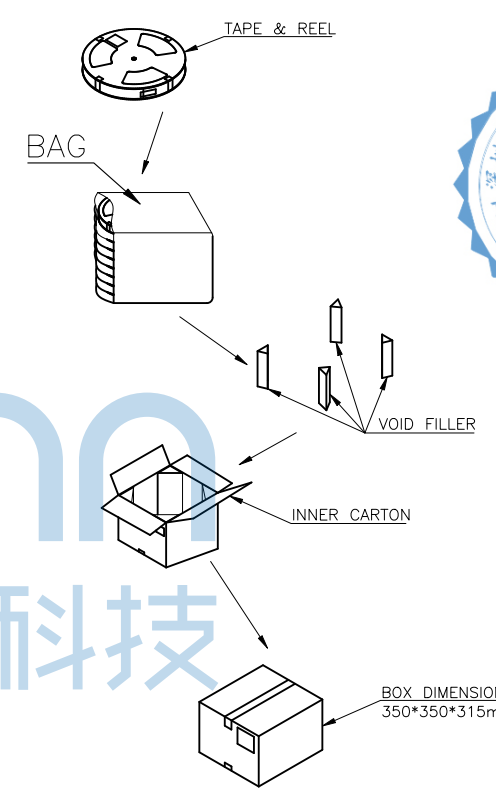
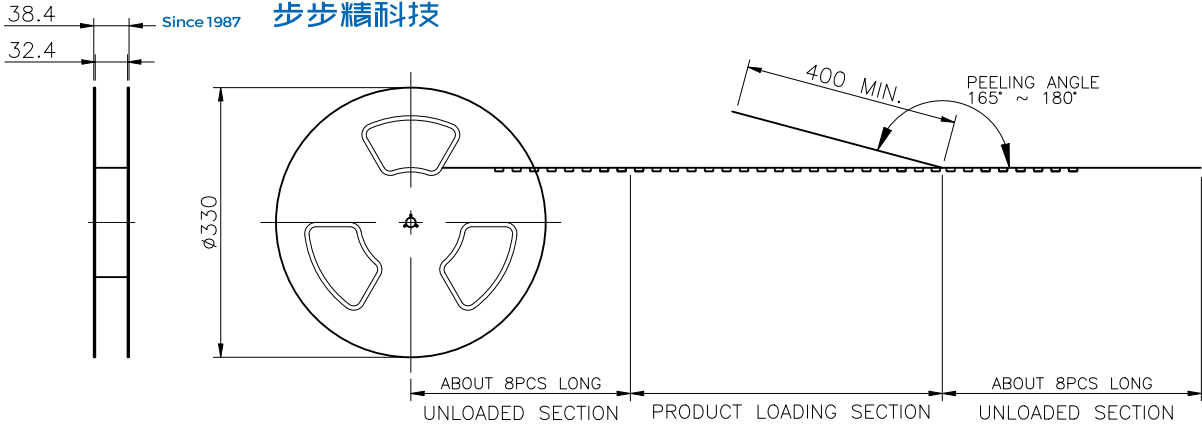

NOTE:

- MATERIAL:**
BOX: FIBREBOARD, CORRUGATED, DOUBLE WALL.
TAPE: POLYSTYRENES, HEAT-RESISTANT TEMPERATURE: 120°C, Transparent color(透明色).
REEL: POLYSTYRENES, HEAT-RESISTANT TEMPERATURE: 70°C, BLUE COLOR.
BAG: POLYETHYLENE, HEAT-RESISTANT TEMPERATURE: 100°C.
- PEELING STRENGTH: 0.1 ~ 1.3 N (10 ~ 130 GRAMS)
- PEELING SPEED: 300 mm/min.
- EACH BAG SHALL BE INCLUDED DESICCANT.



400	8	3200 PCS	-- KG	-- KG	1.26 g
PCS/ REEL	REELS/ CARTON	QUANTITY	GROSS WEIGHT	NET WEIGHT	Single WEIGHT

THIS DOCUMENT IS THE SOLE PROPERTY OF **bbJconn Technology Co., Ltd.**

深圳市步步精科技有限公司

NAME: USB 3.0 AF 90° 反向沉板 沉板4.04 L=12.5 CH=-1.34 直脚 1.35 短款平口 锡脚长1.35 DIP LCP蓝色 不锈钢壳 带焊点

PJ. NO.: UB.03.32-33-W004

SIZE: A4 DRW NO.:

FINISH: SEE NOTES MAT'L.: SEE NOTES

SCALE: N/A REV.: A0 UNIT: mm PAGE: 1/1

APPD.	JM_Zheng	23/05'02
CHKD.	TSP	23/05'02
DR.	LYX	23/05'02

PDWG.NO: 0536-1