

REV.	DESCRIPTION	NAME	DATE
A	NEWS ISSUE		

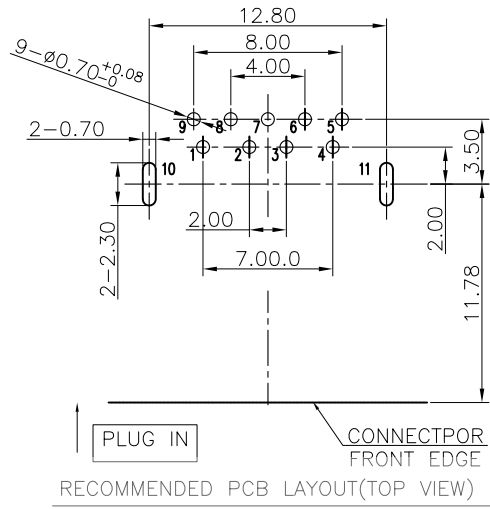

RECOMMENDED PCB LAYOUT(TOP VIEW)
TOLERANCE:±0.03mm
RECOMMEND PCB THICKNESS:t1.6&1.2mm



NOTES:

1. MATERIAL:

- 1.1 HOUSING: HIGH TEMPERATURE THERAL PLASTIC LCP/PBT.
- 1.2 SPRING CONTACT: COPPER ALLOY.
- 1.3 FLAT CONTACT;COPPER ALLOY
- 1.4 SHELL :COPPER ALLOY C2680/SPCC.
- 1.5 COVER:HIGIH TEMPERATURE THERAL PLASTIC.

2. FINISH:

- 2.1 CONTACT: G/F, [50m"] MIN. NICKEL UNDERPLATING OVER ALL.
- 2.2 SHELL: [50m"] MIN. SOLDERABILITY NICKEL UNDERPLATING OVER ALL.

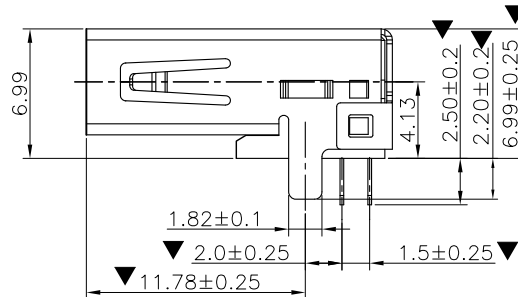
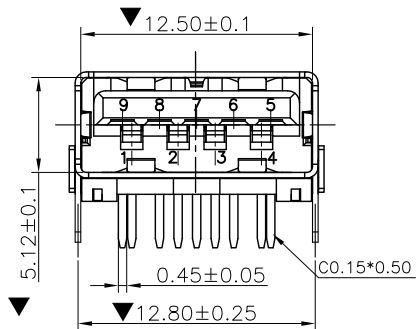
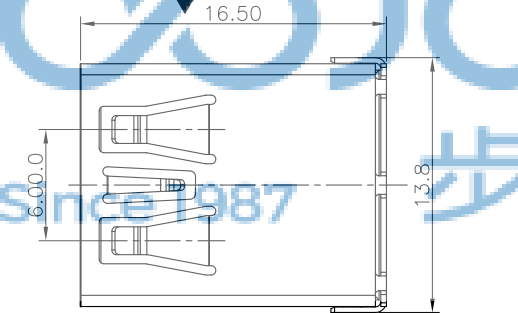
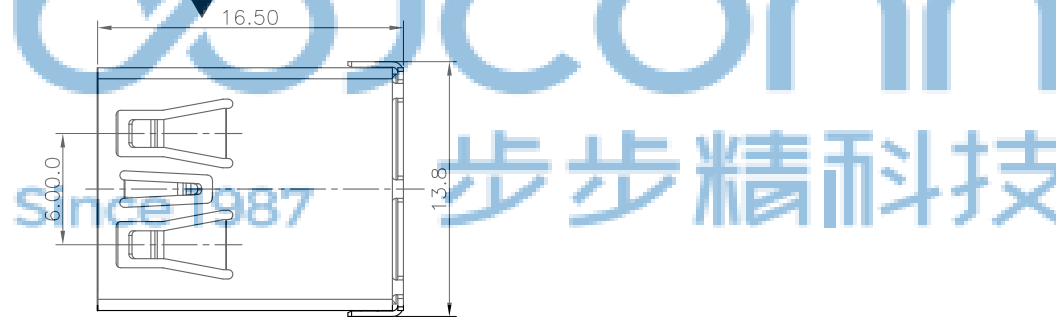
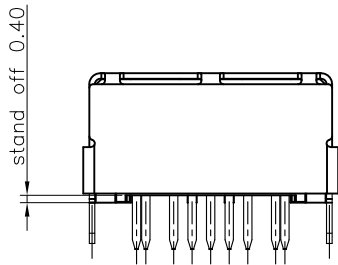
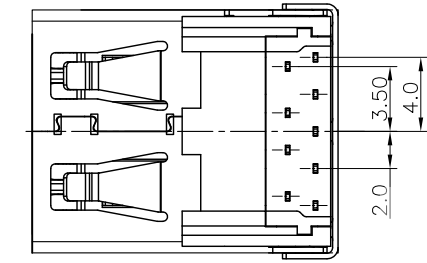

TOLERANCE UNSPECIFIED

.0	±0.35
.00	±0.25
.000	±0.15
X. °	±2.00°

CUSTOMER DRAWING

深圳市步步精科技有限公司

TITLE:
USB 3.0 AF 90度 L=16.50 后两脚插 直脚 端子DIP 平口 PBT蓝胶 铁壳

DRAWN/ DATE	设计 TSP	SIZE:A4	UNIT:MM.	PART. NO: 127-272-090027-P2G	
CHECKED/ DATE	审核 LYX	SCALE: 1:1	PROJECTION		REV.: 版本
APPROVED/ DATE	核准 LJP	DWG. PATH	0536-1		SHEET: 页码

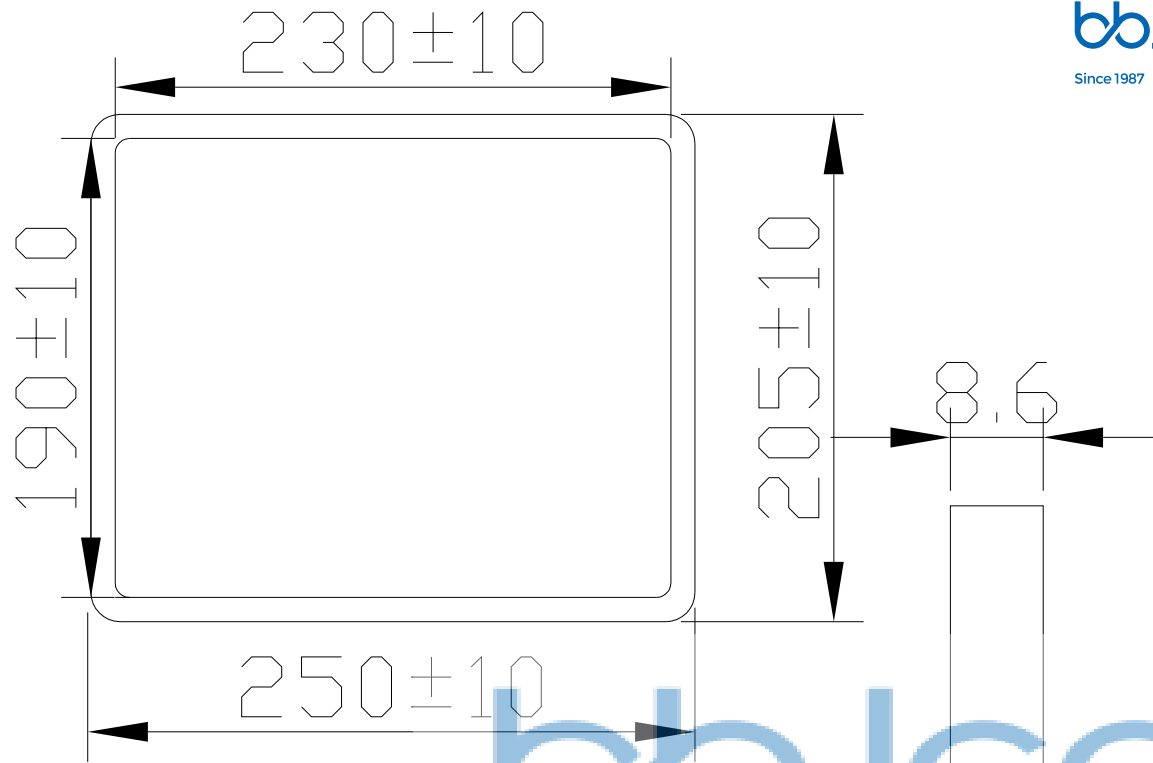

bbJconn
Since 1987 步步精科技

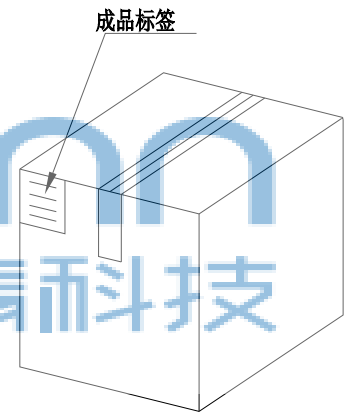
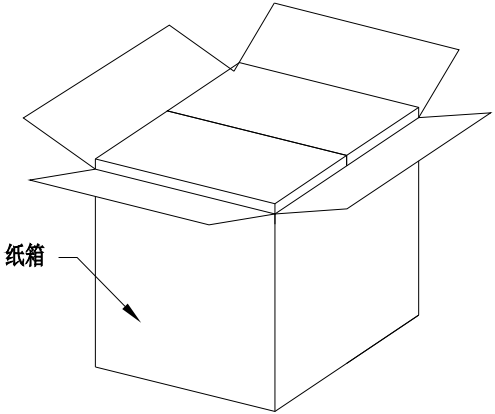

bbJconn
Since 1987 步步精科技

纸箱规格: 350*210*290

1. 包装要求:
- 1.1 每盒吸塑盒包装100pcs;
 - 1.2 每20盘放一箱, 共计2000PCS;
 - 1.3 纸箱外贴上标签



TOLERANCE UNSPECIFIED		深圳市步步精科技有限公司 TITLE: USB 3.0 AF 90度 L=16.50 后两脚插 直脚 端子DIP 平口 PBT蓝胶 铁壳			
.0	±0.35	SIZE: A4	UNIT: MM.	PART. NO: 127-272-090027-P2G	
.00	±0.25	CHECKED/ DATE	SCALE: 1:1	PROJECTION	REV.: 版本
.000	±0.15	APPROVED/ DATE	DWG. PATH	0536-1	SHEET: 页码
X. °	±2.00°	设计 TSP			
CUSTOMER DRAWING		审核 LYX			
		核准 LJP			