

REV.	ECN NO.	CONTENT	DATE	ENGINEER
A0		Initial release	/	SGF

NOTE:

1. MATERIAL:

- 1.1 INSULATOR: HIGH TEMPERATURE PLASTIC UL 94 V-0; BLUE
- 1.2 CONTACT: COPPER ALLOY (T=0.20mm)
- 1.3 SHELL: SUS201 (T=0.30mm)

2. ELECTRICAL CHARACTERISTICS:

- 2.1 CONTACT RESISTANCE: 30mΩ Max
- 2.2 CONTACT CURRENT RATING: 1.5A
- 2.3 DIELECTRIC WITHSTANDING VOLTAGE: 500 V R. M. S.
- 2.4 INSULATION RESISTANCE 1000 MEGOHMS Min

3. MECHANICAL CHARACTERISTICS:

- 3.1 MATING FORCE: 35 N Max
- 3.2 UNMATED FORCE: 10 N Min INITIAL; 8 N Min AFTER TEST
- 3.3 DURABILITY: 5,000 CYCLES

4. PLATING

- 4.1 TERMINAL CONTACT: (SEE TAB) GOLD PLATING ALL OVER
50u" MIN NICKEL AND 100u" MIN MATTE Tin ALL OVER 50u"
MIN NICKEL ON SOLDER AREA
- 4.2 SHELL: 50u" MIN. NICKEL ALL OVER

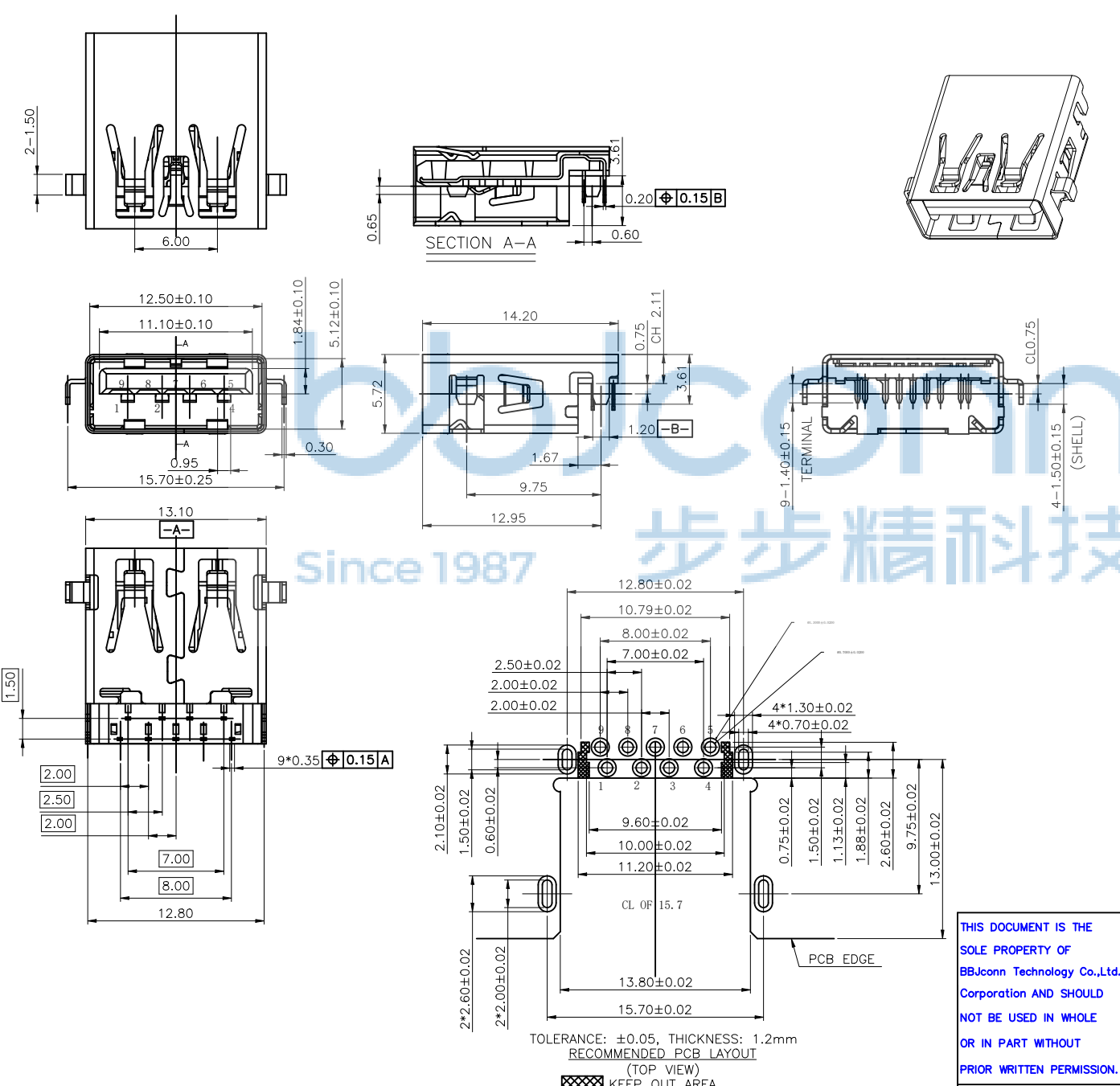

THIS DOCUMENT IS THE SOLE PROPERTY OF BBJconn Technology Co., Ltd. Corporation AND SHOULD NOT BE USED IN WHOLE OR IN PART WITHOUT PRIOR WRITTEN PERMISSION.		深圳市步步精科技有限公司	
.X: ±0.38 X': ±3" .XX: ±0.25 X'': ±2" .XXX: ±0.13 .XX': ±1"		NAME: USB 3.0 A母 90度 四脚插 端子DIP 平口 L=14.2 沉板4.6 CH=2.11 LCP蓝胶 不锈钢外壳 编带	
APPD.	JM_Zheng	PJ. NO.: 127-272-090031-P2G	
CHKD.	LYX	SIZE: A4 DRW NO.:	
PDWG.NO:	0536-1	FINISH: SEE NOTES	MAT'L: SEE NOTES
DR.	SGF	SCALE: N/A	REV.: A0 UNIT: mm PAGE: 1/2

TOLERANCE: ±0.05, THICKNESS: 1.2mm
RECOMMENDED PCB LAYOUT
(TOP VIEW)
KEEP OUT AREA

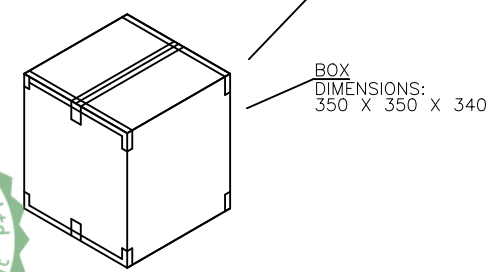
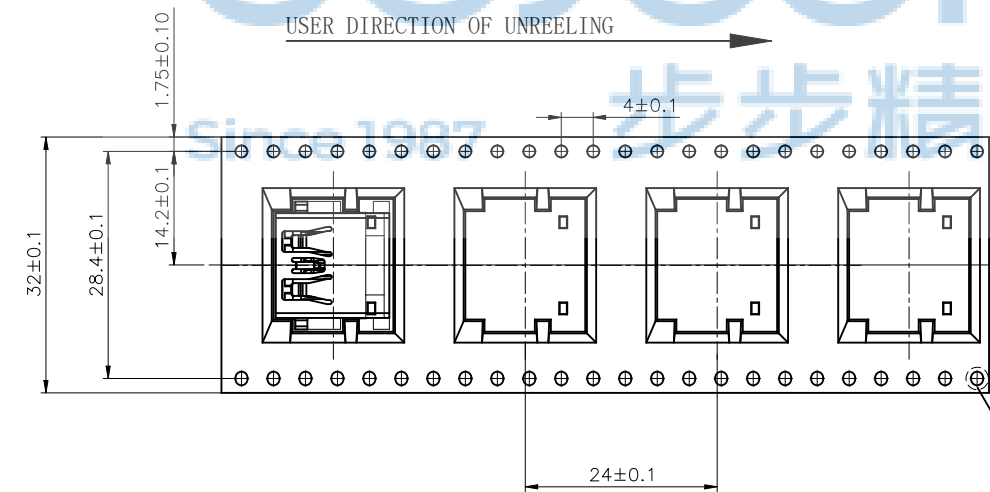
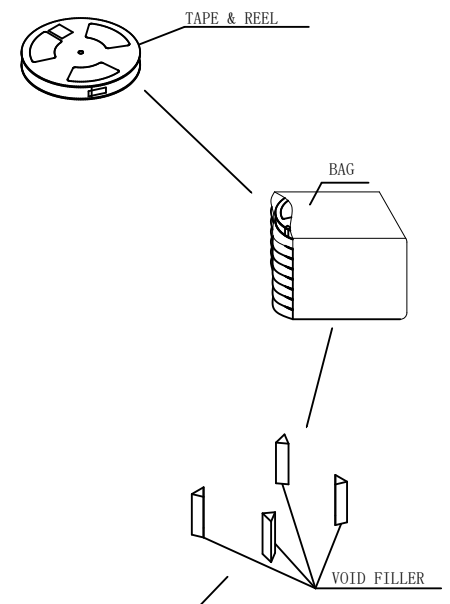
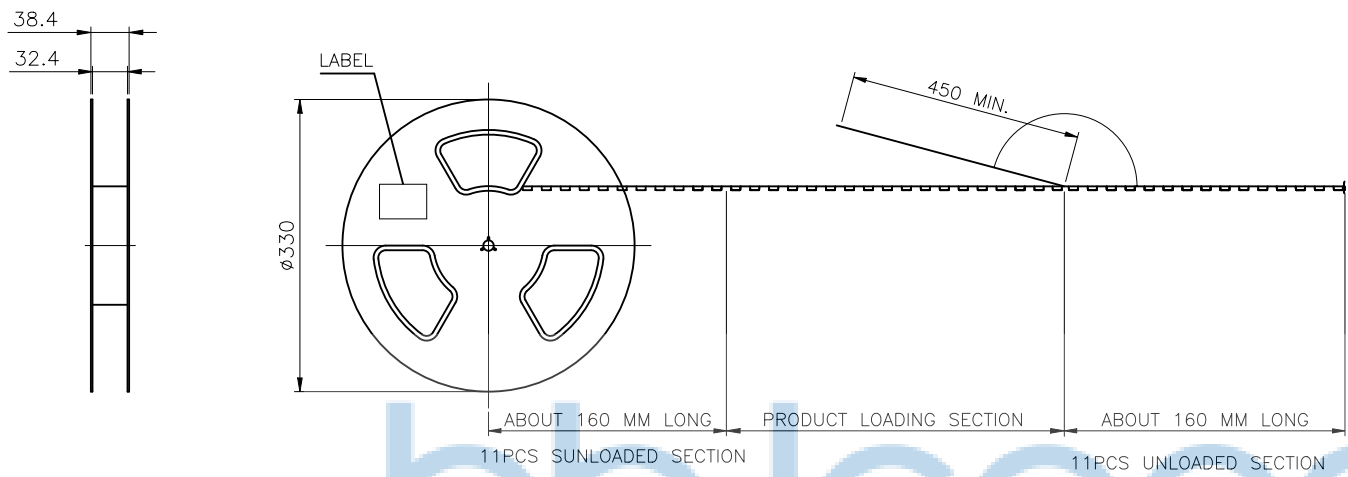

- NOTE:**
- MATERIAL:**
 BOX: FIBREBOARD, CORRUGATED, DOUBLE WALL.
 TAPE: POLYSTYRENES, HEAT-RESISTANT TEMPERATURE: 120° C, BLACK COLOR.
 REEL: POLYSTYRENES, HEAT-RESISTANT TEMPERATURE: 70° C, BLUE COLOR.
 BAG: POLYETHYLENE, HEAT-RESISTANT TEMPERATURE: 100° C.
 - PEELING STRENGTH:** 0.1 ~ 1.3 N (10 ~ 130 GRAMS)
 - PEELING SPEED:** 300 mm/min.
 - EACH BAG SHALL BE INCLUDED DESICCANT.**

450	8	3600 PCS	-- KG	-- KG
REEL	REELS/CARTON	QUANTITY	GROSS WEIGHT	NET WEIGHT

THIS DOCUMENT IS THE SOLE PROPERTY OF BBJconn Technology Co., Ltd. Corporation AND SHOULD NOT BE USED IN WHOLE OR IN PART WITHOUT PRIOR WRITTEN PERMISSION.

PDWG.NO: 0536-1

深圳市步步精科技有限公司

NAME: USB 3.0 A母 90度 四脚插 端子DIP 平口 L=14.2 沉板4.6 CH=2.11 LCP蓝胶 不锈钢外壳 编带

PJ. NO.: 127-272-090031-P2G

SIZE: A4 DRW NO.:

FINISH: SEE NOTES MAT'L.: SEE NOTES

SCALE: N/A REV.: A0 UNIT: mm PAGE: 2/2

APPD.	JM_Zheng
CHKD.	LYX
DR.	SGF