

REV	ECN NO	CONTENT	DATE	ENGINEER
A0		INITIAL RELEASE	/	SGF

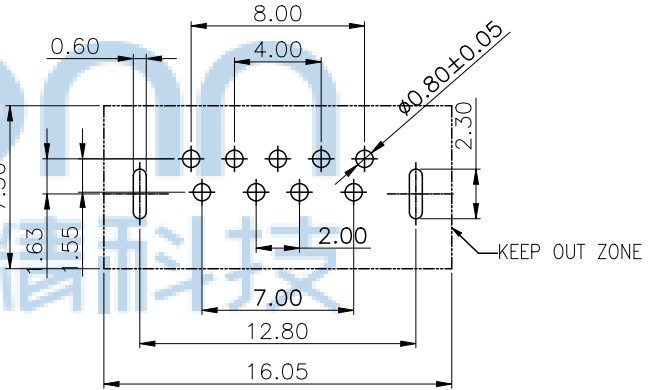

NOTE:
 1.MATERIAL:
 1.1 INSULATOR:HIGH TEMPERATURE PLASTIC
 1.2 CONTACT:BRONZE
 1.3 SHELL:STAINLESS STEEL
 2.ELECTRICAL CHARACTERISTICS:
 2.1 CONTACTRESISTANCE:30mΩ MAX
 2.2 CONTACT CURRENT RATING:1.5A
 2.3 DIELECTRIC WITHSTANDING VOLTAGE:100 V R.M.S.
 2.4 INSULATION RESISTANCE 100 MΩ MIN
 2.5 OPERATING TEMPERATURE:-40°C ~ 85°C
 3 MECHANICAL CHARACTERISTICS:
 3.1 MATING FORCE:3.57kgf MAX
 3.2 UNMATING FORCE:1.02kgf MIN
 3.3 DURABILITY:MANDATORY:1,500 CYCLES
 4.PLATING
 4.1 TERMINAL:
 50u" MIN NICKEL ALL OVER
 120u"MIN Tin ON SOLDER AREA
 (1~30)u"Au ON CONTACT AREA
 4.2 SHELL:50u"MIN.NICEL ALL OVER

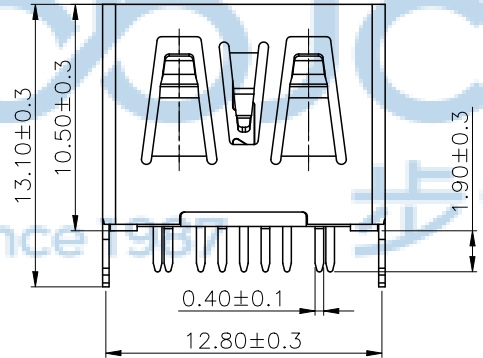
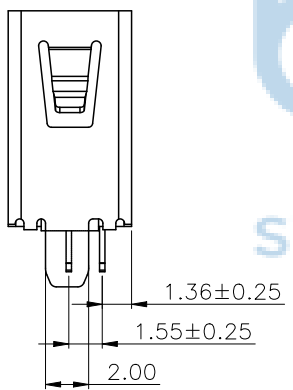
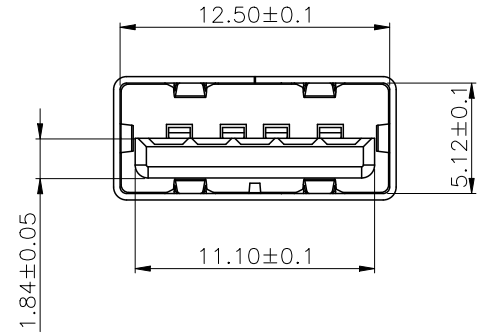

Recommended PCB Layout
 PCB Thickness=1.8±0.1mm

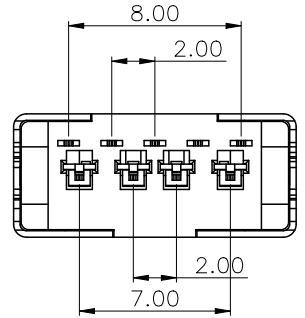

Pin NUMBER	SIGNAL NAME
1	VBUS
2	D-
3	D+
4	GND
5	StdA_SSRX-
6	StdA_SSRX+
7	GND_DRAIN
8	StdA_SSTX-
9	StdA_SSTX+
Shell	Shield



THIS DOCUMENT IS THE SOLE PROPERTY OF BBJconn Technology Co.,Ltd. Corporation AND SHOULD NOT BE USED IN WHOLE PRIOR WRITTEN PERMISSION.

PDWG NO: 0536-1

深圳市步步精科技有限公司

NAME: USB 3.0 AF 180度 H=10.50 直脚 端子DIP 平口 PBT蓝胶 不锈钢外壳 编带

APPD	JM_Zheng	FINISH:SEE NOTES	MAT'L:SEE NOTES
CHKD	LYX	SCALE:N/A	REV:A0
DR	SGF	UNIT:mm	PAGE:1/2

REV	ECN NO	CONTENT	DATE	ENGINEER
AO		INITIAL RELEASE	/	SGF

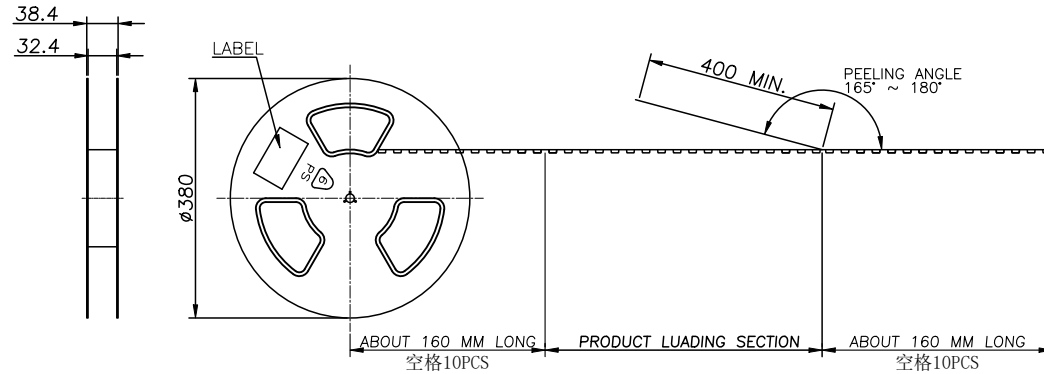

- NOTE:
- MATERIAL:
BOX: FIBREBOARD, CORRUGATED, DOUBLE WALL.
TAPE: POLYSTYRENES, HEAT-RESISTANT TEMPERATURE: 120°C, Transparent COLOR.
REEL: POLYSTYRENES, HEAT-RESISTANT TEMPERATURE: 70°C, BLUE COLOR.
BAG: POLYETHYLENE, HEAT-RESISTANT TEMPERATURE: 100°C.
 - PEELING STRENGTH: 0.1 ~ 1.3 N (10 ~ 130 GRAMS)
 - PEELING SPEED: 300 mm/min.
 - EACH BAG SHALL BE INCLUDED DESICCANT.

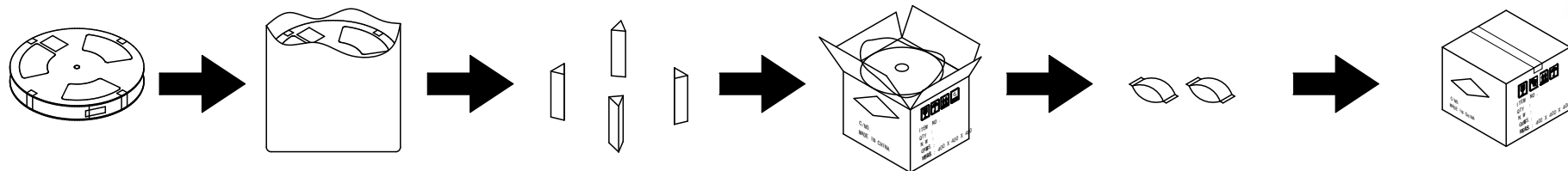
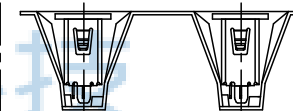
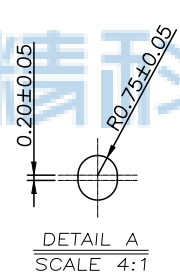
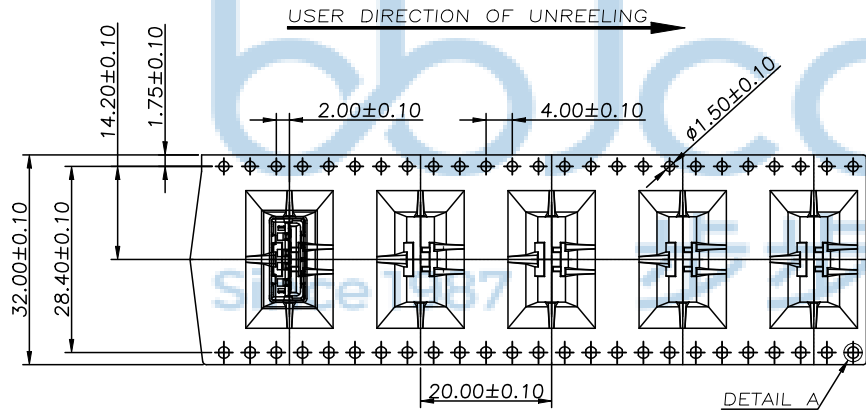

Each reels contains 280 PCS Each bag contains 10 reels Put 4PCS corner protector in each box Put 10PCS rolls in each box Put 2PCS desiccant in each box Box dimensions:400 X 400 X 400

THIS DOCUMENT IS THE SOLE PROPERTY OF BBJconn Technology Co.,Ltd. Corporation AND SHOULD NOT BE USED IN WHOLE PRIOR WRITTEN PERMISSION.		深圳市步步精科技有限公司	
.X: ±0.38 .XX: ±0.25 .XXX: ±0.13		X': ±3" X'': ±2" .XX': ±1"	
APPD	JM_Zheng	NAME: USB 3.0 AF 180度 H=10.50 直脚 端子DIP 平口 PBT蓝胶 不锈钢外壳 编带	
CHKD	LYX	PJ NO: 127-275-090008-P2G	
DR	SGF	SIZE:A4 DRW NO:	
PDWG NO: 0536-1		FINISH:SEE NOTES MAT'L:SEE NOTES	
		SCALE:N/A REV:AO UNIT:mm PAGE:2/2	

400 PCS	10 R	4000 PCS	-- KG	-- KG
PSC/Reel	Reel/CARTON	QUANTITY	CROSS WEIGHT	NET WEIGHT