

REV.	ECN NO.	CONTENT	DATE	ENGINEER
A0		Initial release		LYX

- NOTE:
- MATERIAL:
 - INSULATOR:HIGH TEMPERATURE PLASTIC
 - CONTACT:BRONZE
 - SHELL:BRASS
 - ELECTRICAL CHARACTERISTICS:
 - CONTACT RESISTANCE:30mΩ MAXIMUM
 - CONTACT CURRENT RATING:1.5A
 - DIELECTRIC WITHSTANDING VOLTAGE:100 V AC R. M. S.
 - INSULATION RESISTANCE 100 MEGOHMS MIN
 - OPERATING TEMPERATURE:-40° C ~ 85° C
 - MECHANICAL CHARACTERISTICS:
 - MATING FORCE:3.57kgf MAX
 - UNMATED FORCE:0.82kgf MIN AFTER TEST
 - DURABILITY MANDATORY:1500 CYCLES
 - PLATING
 - TERMINAL:
 - 50u" MIN NICKEL ALL OVER
 - 80u"MIN Tin ON SOLDER AREA
 - (1~30)u"Au ON CONTACT AREA
 - SHELL:50u"MIN. NICEL ALL OVER

C1款

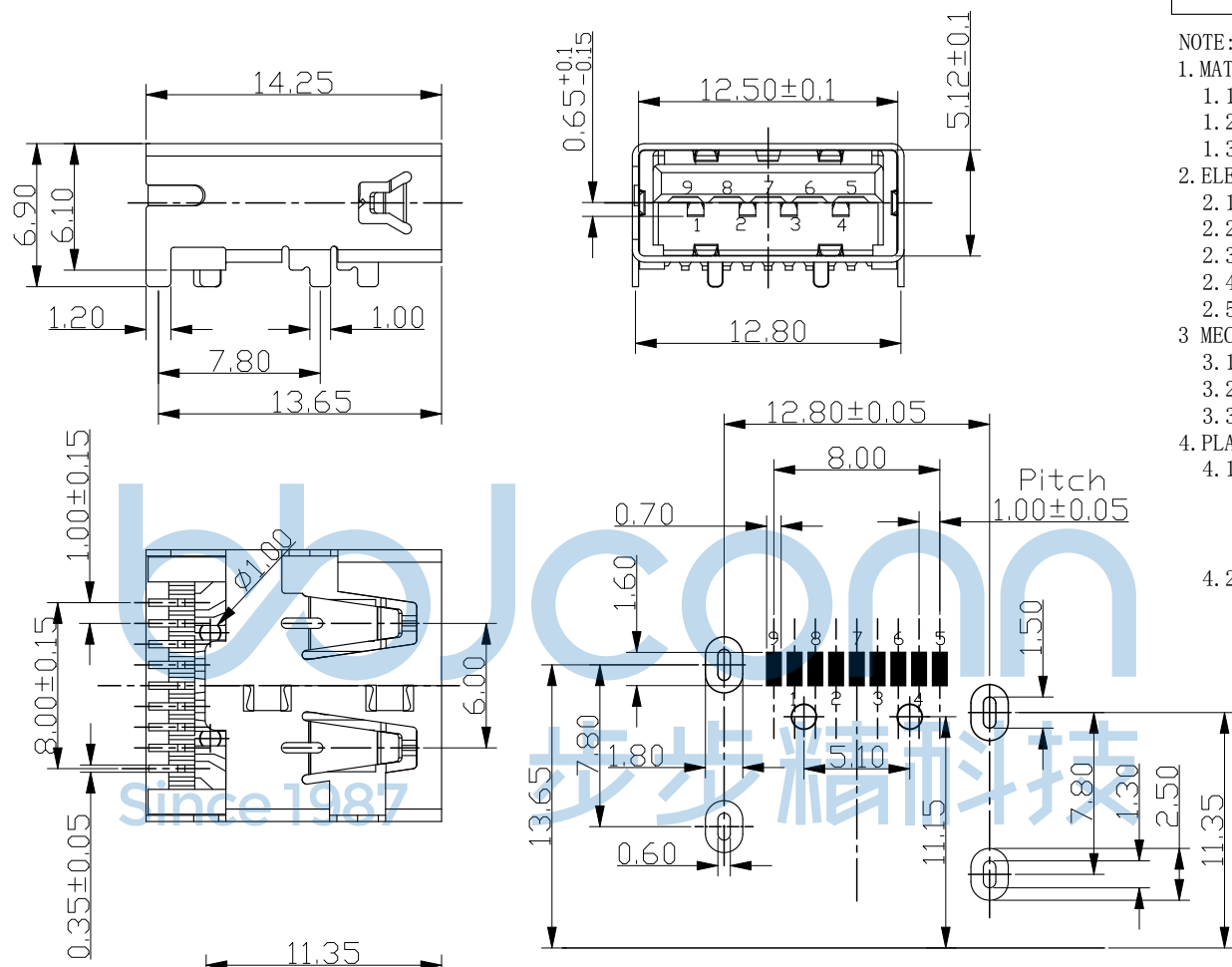

RECOMMENDED PCB LAYOUT
TOLERANCE: ±0.05mm

Pin NUMBER	SIGNAL NAME
1	VBUS
2	D-
3	D+
4	GND
5	StdA_SSRX-
6	StdA_SSRX+
7	GND_DRAIN
8	StdA_SSTX-
9	StdA_SSTX+
Shell	Shield



THIS DOCUMENT IS THE SOLE PROPERTY OF BBJconn Technology Co.,Ltd. Corporation AND SHOULD NOT BE USED IN WHOLE OR IN PART WITHOUT PRIOR WRITTEN PERMISSION.		深圳市步步精科技有限公司 .X: ±0.38 .X°: ±3° .XX: ±0.25 .X°: ±2° .XXX: ±0.13 .XX°: ±1°		NAME: USB 3.0 A母 90度 短体 SMT 四脚插 错位 带柱 带凸点 L=14.25 H=6.10 平口 铜壳 LCP蓝胶 C1款 编带	
APPD.	JM_Zheng	P.J. NO.: 125-271-090001-K4G		SIZE: A4 DRW NO.:	
CHKD.	TSP	FINISH: SEE NOTES		MAT' L.: SEE NOTES	
PDWG.NO:	0886-1	DR.	LYX	SCALE: N/A	REV.: A0 UNIT: mm PAGE: 1/2



REV.	ECN NO.	CONTENT	DATE	ENGINEER
A0		Initial release		LYX

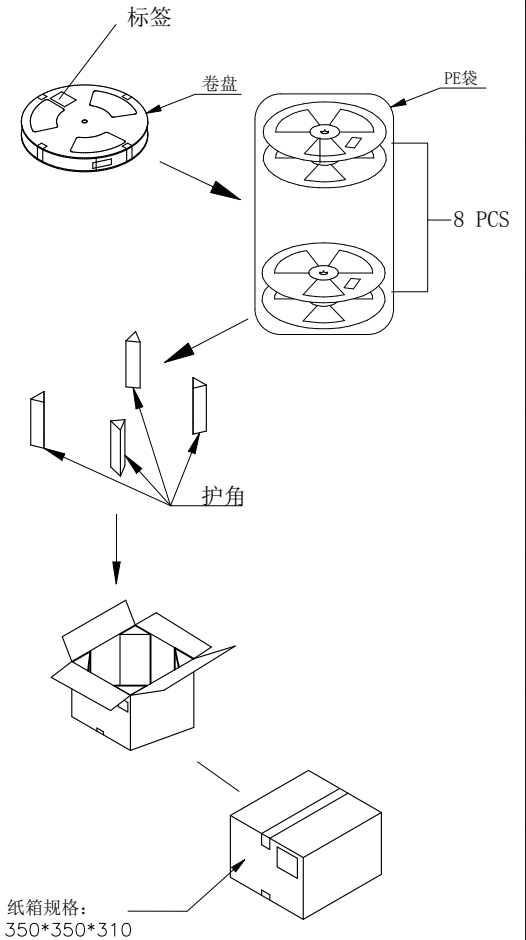
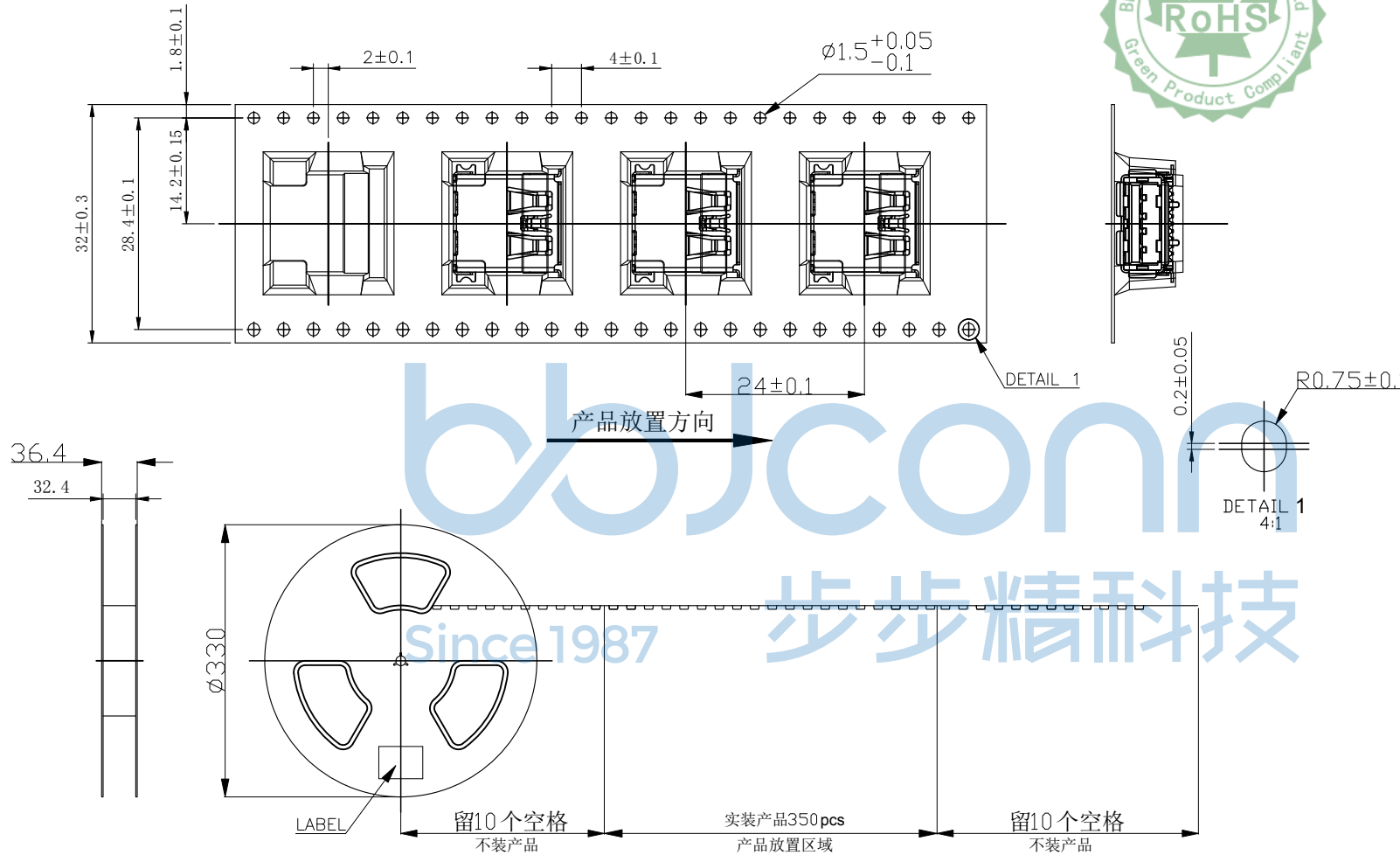

NOTE:

- MATERIAL:
BOX: FIBREBOARD, CORRUGATED, DOUBLE WALL.
TAPE: POLYSTYRENES, HEAT-RESISTANT TEMPERATURE: 120°C, 透明 COLOR.
REEL: POLYSTYRENES, HEAT-RESISTANT TEMPERATURE: 70°C, BLUE COLOR.
BAG: POLYETHYLENE, HEAT-RESISTANT TEMPERATURE: 100°C.
- PEELING STRENGTH: 0.1 ~ 1.3 N (10 ~ 130 GRAMS)
- PEELING SPEED: 300 mm/min.
- EACH BAG SHALL BE INCLUDED DESICCANT.



350	8	2800 PCS	-- KG	-- KG
PCS/ REEL	REELS/ CARTON	QUANTITY	GROSS WEIGHT	NET WEIGHT

THIS DOCUMENT IS THE SOLE PROPERTY OF BBJconn Technology Co., Ltd. Corporation AND SHOULD NOT BE USED IN WHOLE OR IN PART WITHOUT PRIOR WRITTEN PERMISSION.

深圳市步步精科技有限公司

NAME: USB 3.0 A母 90度 短体 SMT 四脚插 错位 带柱 带凸点
L=14.25 H=6.10 平口 铜壳 LCP蓝胶 C1款 编带

APPD. JM_Zheng
CHKD. TSP
DR. LYX

PJ. NO.: 125-271-090001-K4G
SIZE: A4 DRW NO. :
FINISH: SEE NOTES MAT' L. : SEE NOTES
SCALE: N/A REV.: A0 UNIT: mm PAGE: 2/2

PDWG.NO: 0886-1