

REV.	ECN NO.	CONTENT	DATE	ENGINEER
A0		Initial release	/	TSP

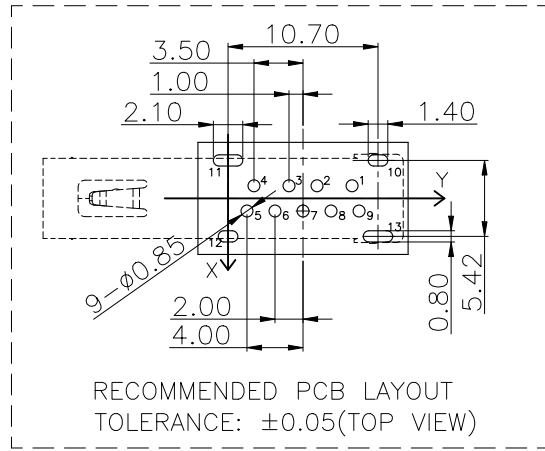

SPECIFICATIONS:
 Contact current Rating:
 1.8 Amperes for pin1&pin4.
 0.25 Amperes other contacts
 Dielectric Withstanding Voltage:AC 100V(RMS)
 Insulation resistance:100Megohms Minimum.
 Contact Resistance:
 30mΩ Max for pin1&pin4
 50mΩ Max for other contacts
 Mechanical Characteristics:
 Mating Force:35 Newtons.Maximum
 Unmating Force:10 Newtons.Minimum.
 Operating Temperature:-40 °C+85 °C

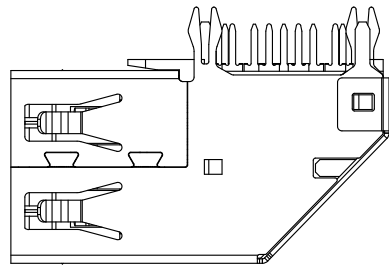
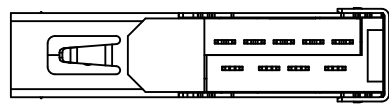
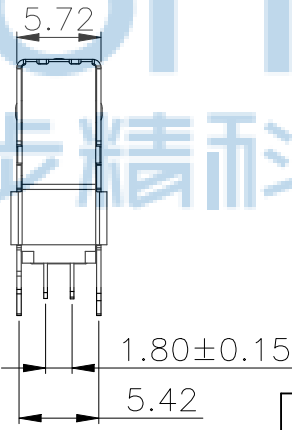
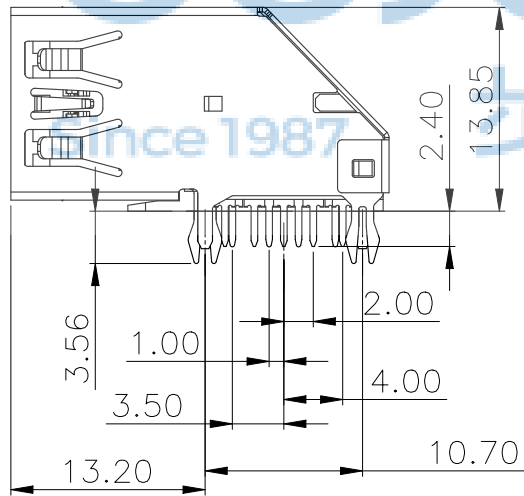
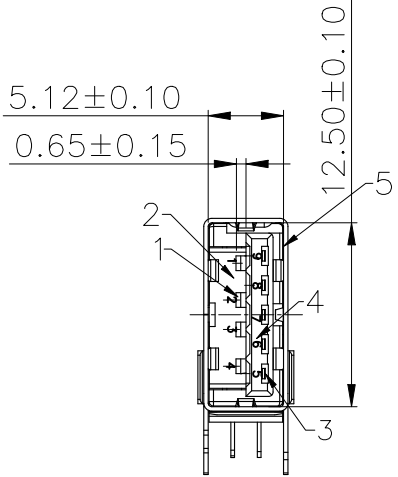
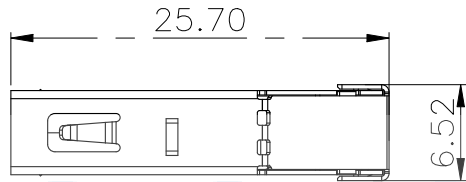

Pin Number	Signal Name	Pin Number	Signal Name
1	VBUS	5	SSRX-
2	D-	6	SSRX+
3	D+	7	GND
4	GND	8	SSTX-
Shell	Shield	9	SSRT+

ITEM	PART NAME	Material	Q'TY	REMARK
1	4P Semi-manufactured Goods	Housing LCP&PBT	1	Black &Blue UL94V-0
2		Contact COPPER ALLOY	4	T=0.25 Plating Gild/Tin
3	5P Semi-manufactured Goods	Housing LCP&PBT	1	Black &Blue UL94V-0
4		Contact COPPER ALLOY	5	T=0.25 Plating Gild/Tin
5	Shell	Stainless Steel	1	T=0.3

THIS DOCUMENT IS THE
 SOLE PROPERTY OF
 BBJconn Technology Co.,Ltd.
 Corporation AND SHOULD
 NOT BE USED IN WHOLE
 OR IN PART WITHOUT
 PRIOR WRITTEN PERMISSION.
 PDWG.NO: 0886-1

深圳市步步精科技有限公司

NAME: USB 3.0 A母 侧插 DIP
 小鱼叉直脚 平口 LCP蓝胶 不锈钢外壳 L=25.70 编带

APPD. JM_Zheng
 CHKD. LYX
 DR. TSP

PJ. NO.: 127-272-090004-K4G
 SIZE: A4 DRW NO.:
 FINISH: SEE NOTES MAT'L.: SEE NOTES
 SCALE: N/A REV.: A0 UNIT: mm PAGE: 1/2

REV.	ECN NO	CONTENT	DATE	ENGINEER
A0		Initial release	/	SGF

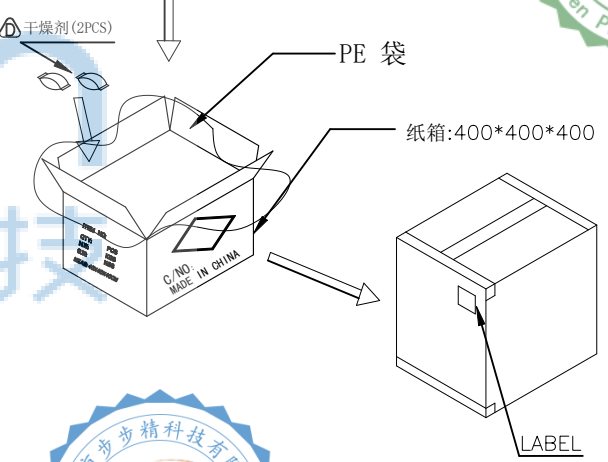
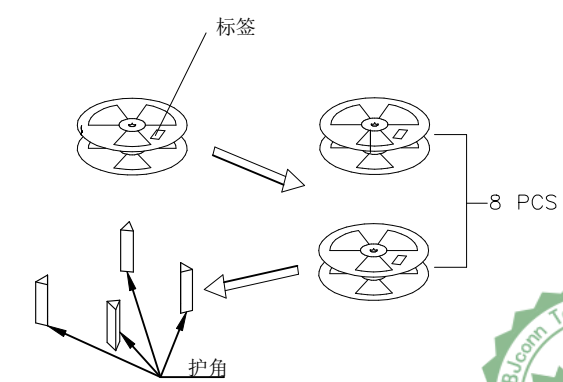
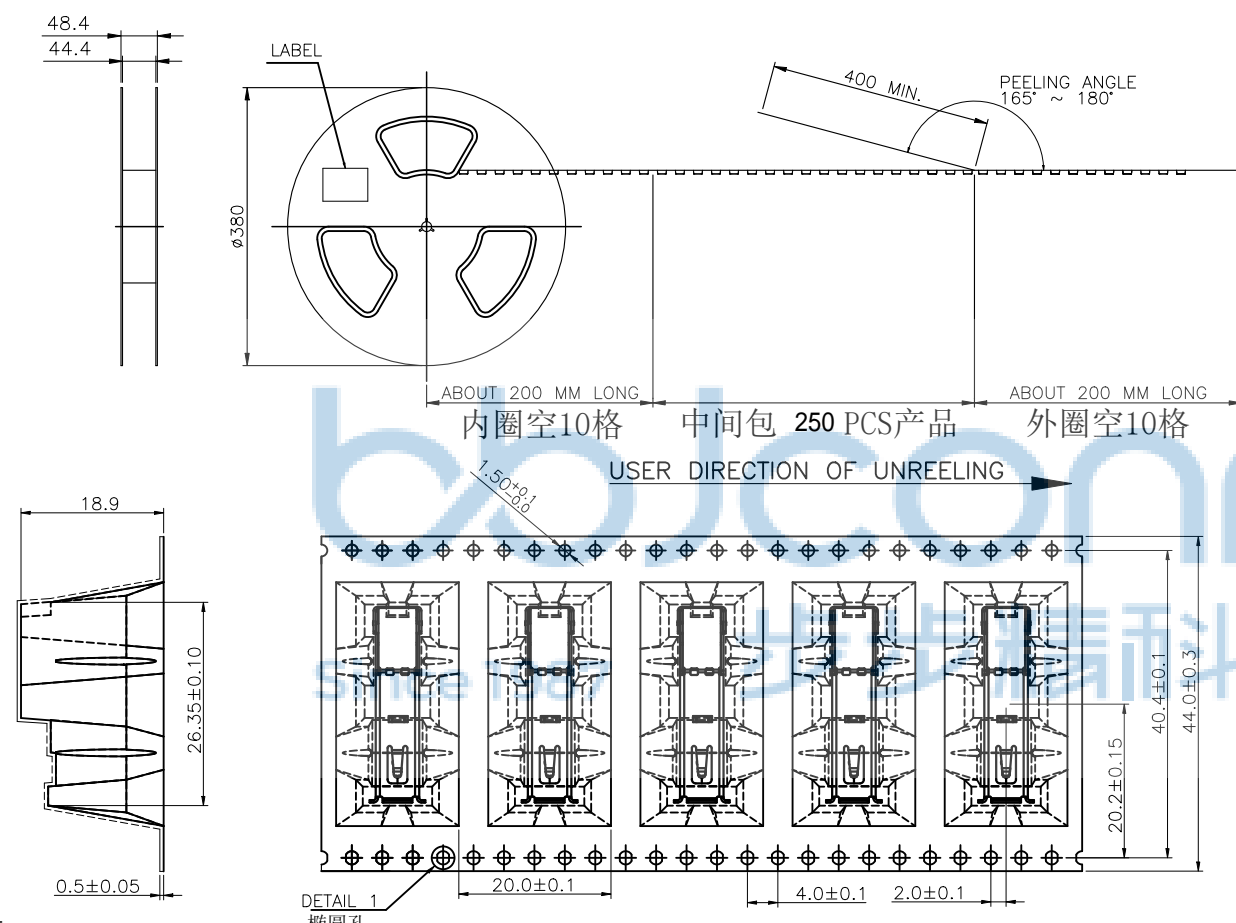

NOTE:

1. PEELING SPEED: 300mm/MINUTE
2. PEELING RESISTANCE: 20g~130g
3. PEELING ANGLE: 165°~180°
4. TAPE: POLYETHYLENE BLACK
5. REEL: POLYETHYLENE BLUE COLOR.
6. Encapsulation process: Cold sealing packing

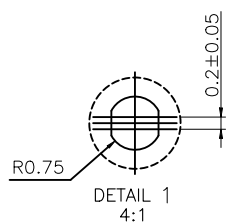

250	8	2000 PCS	-- KG	-- KG
PCS/ REEL	REELS/ CARTON	QUANTITY	GROSS WEIGHT	NET WEIGHT

THIS DOCUMENT IS THE SOLE PROPERTY OF BBJconn Technology Co., Ltd. Corporation AND SHOULD NOT BE USED IN WHOLE OR IN PART WITHOUT PRIOR WRITTEN PERMISSION.		深圳市步步精科技有限公司 工程管理部	
PDWG.NO:	0886-1	DR.	SGF
NAME: USB 3.0 A母 侧插 DIP 小叉直脚 平口 LCP蓝胶 不锈钢外壳 L=25.70 编带		PJ. NO.: 127-272-090004-K4G SIZE: A4 DRW NO.: FINISH: SEE NOTES MAT'L.: SEE NOTES SCALE: N/A REV.: A0 UNIT: mm PAGE: 2/2	