

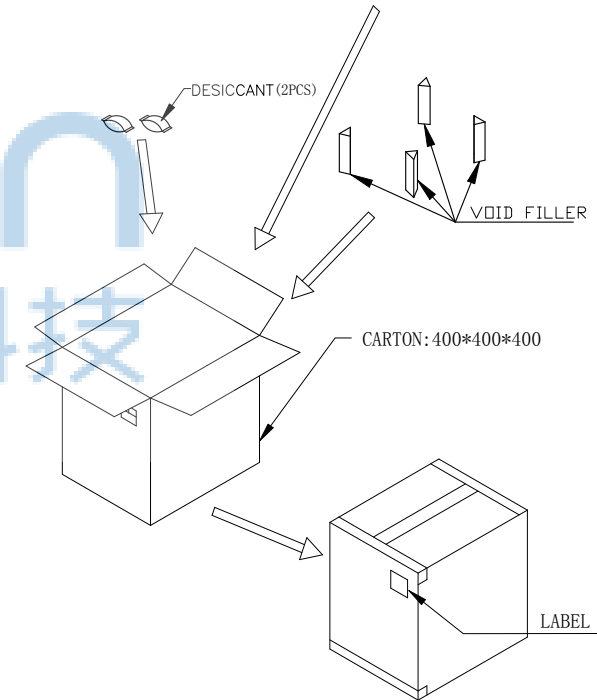

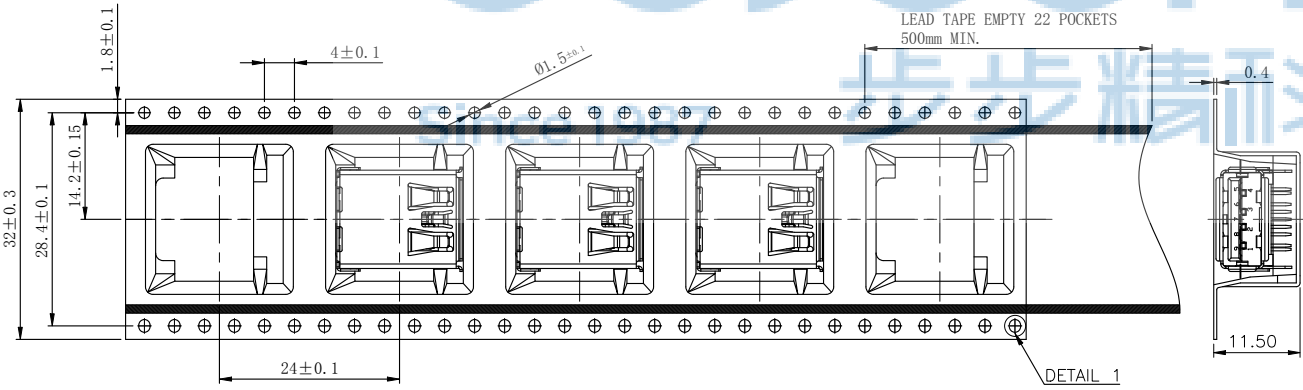

REV.	ECN NO.	CONTENT	DATE	ENGINEER
A0		Initial release	/	TSP

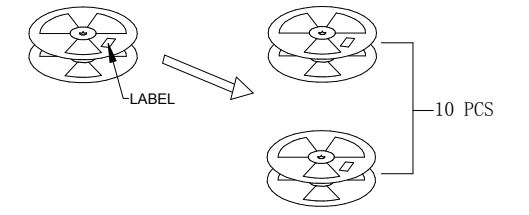
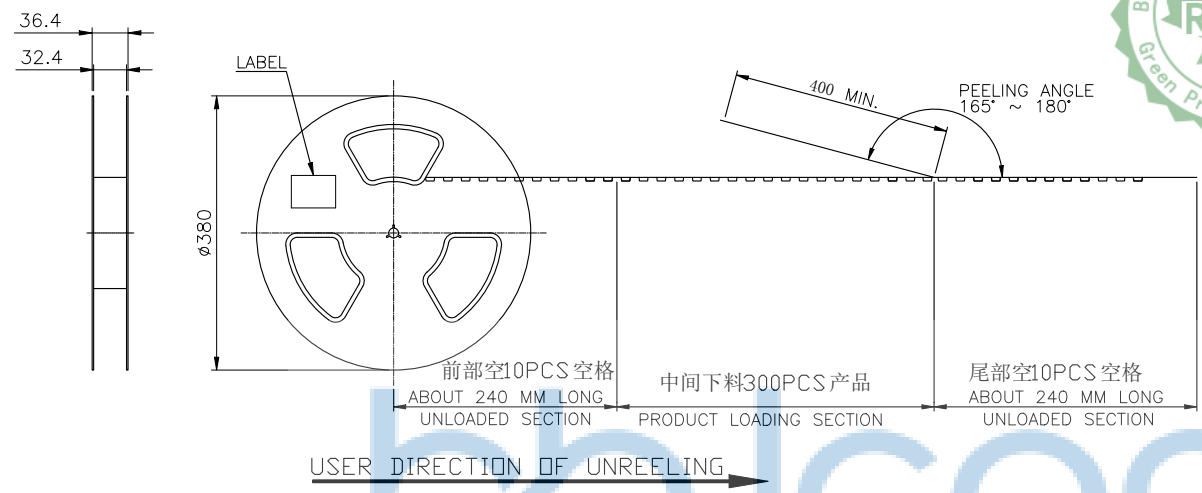

- NOTE:
- MATERIAL:  
BOX: FIBRE BOARD, CORRUGATED, DOUBLE WALL.  
TAPE: POLYSTYRENES, HEAT-RESISTANT TEMPERATURE: 120°C, 透明COLOR.  
REEL: POLYSTYRENES, HEAT-RESISTANT TEMPERATURE: 70°C, BLUE COLOR.  
BAG: POLYETHYLENE, HEAT-RESISTANT TEMPERATURE: 100°C.
  - PEELING STRENGTH: 0.1 ~ 1.3 N (10 ~ 130 GRAMS)
  - PEELING SPEED: 300 mm/min.
  - EACH BAG SHALL BE INCLUDED DESICCANT.

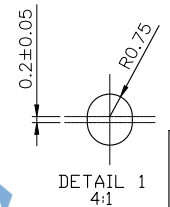

300	10	3000 PCS	-- KG	7.2KG
PCS/ REEL	REELS/ CARTON	QUANTITY	GROSS WEIGHT	NET WEIGHT

THIS DOCUMENT IS THE SOLE PROPERTY OF BBJconn Technology Co., Ltd. Corporation AND SHOULD NOT BE USED IN WHOLE OR IN PART WITHOUT PRIOR WRITTEN PERMISSION.

PDWG.NO: 0886-1

DR. TSP

APPD. JM\_Zheng

CHKD. LYX

深圳市步步精科技有限公司

NAME: USB 3.0 A母 90度 DIP 四脚插 直脚 平口 不锈钢外壳 LCP蓝胶 L=16.50 H=7.0 编带

PJ. NO.: 127-272-090005-K4G

SIZE: A4 DRW NO.:

FINISH: SEE NOTES MAT' L.: SEE NOTES

SCALE: N/A REV.: A0 UNIT: mm PAGE: 1/2