

REV.	ECN NO.	CONTENT	DATE	ENGINEER
A0		Initial release	/	TSP

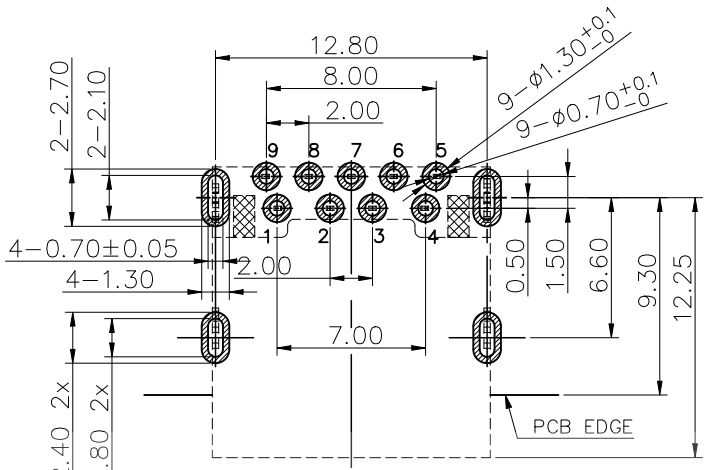

TOLERANCE: ±0.05, THICKNESS: 1.2mm  
RECOMMENDED PCB LAYOUT  
(TOP VIEW)  
KEEP OUT AREA

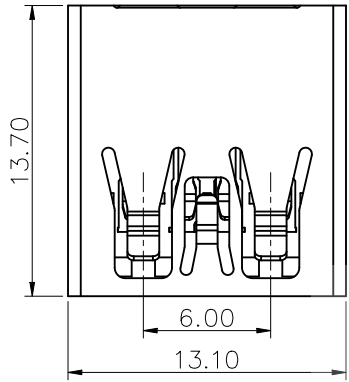
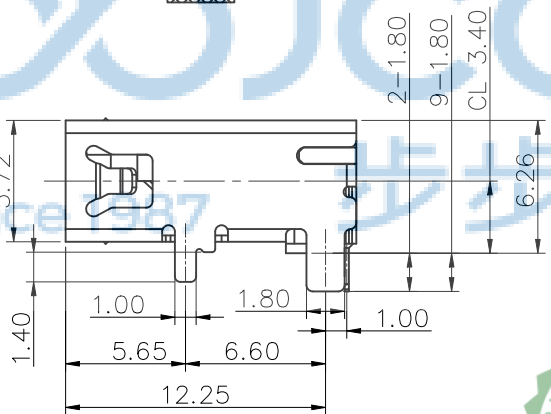
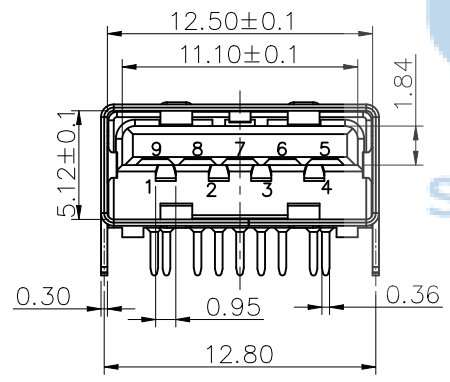

- NOTE:
- MATERIAL:
    - INSULATOR:HIGH TEMPERATURE;LCP BLUE
    - CONTACT:COPPER ALLOY (T=0.20mm)
    - SHELL:SUS201 (T=0.30mm)
  - ELECTRICAL CHARACTERISTICS;
    - CONTACT RESISTANCE:30mΩ Max
    - CONTACT CURRENT RATING:1.5A
    - DIELECTRIC WITHSTANDING VOLTAGE:100 V R. M. S.
    - INSULATION RESISTANCE 100 MEGOHMS Min
    - OPERATING TEMPERATURE:-25° C ~ 75° C
  - MECHANICAL CHARACTERISTICS:
    - MATING FORCE:35 N Max
    - UNMATED FORCE:10 N Min
  - PLATING
    - TERMINAL CONTACT:GOLD PLATING G/F ALL OVER 50u"MIN NICKEL AND 80u"MIN Tin ALL OVER 50u" MIN NICKEL ON SOLDER AREA
    - SHELL:50u"MIN. NICKEL ALL OVER

Pin #	SIGNAL NAME	DESCRIPTION	MATING SEQUENCE
1	VBUS	POWER	SECOND
2	D-	USB 2.0 DIFFERENTIAL PAIR	THIRD
3	D+		
4	GND	GROUND FOR POWER RETURN	SECOND
5	StdA_SSRX-	SUPERSPEED RECEIVER DIFFERENTIAL PAIR	LAST
6	StdA_SSRX+		
7	GND_DRAIN	GROUND FOR SIGNAL RETURN	
8	StdA_SSTX-	SUPERSPEED TRANSMITTER DIFFERENTIAL PAIR	
9	StdA_SSTX+		
Shell	Shield	CONNECTOR METAL SHELL	FRIST

THIS DOCUMENT IS THE SOLE PROPERTY OF BBJconn Technology Co.,Ltd. Corporation AND SHOULD NOT BE USED IN WHOLE OR IN PART WITHOUT PRIOR WRITTEN PERMISSION.

PDWG:NO: 0886-1

DR. TSP

APPD. JM\_Zheng

CHKD. LYX

NAME: USB 3.0 A母 90度 DIP 四脚插 直脚 锡脚长1.80 平口 不锈钢外壳 LCP蓝胶 L=13.70 H=6.26 编带

PJ. NO.: 127-275-090004-K4G

SIZE: A4 DRW NO.:

FINISH: SEE NOTES MAT'L.: SEE NOTES

SCALE: N/A REV.: A0 UNIT: mm PAGE: 1/2

深圳市步步精科技有限公司

REV.	ECN NO.	CONTENT	DATE	ENGINEER
A0		Initial release	/	TSP

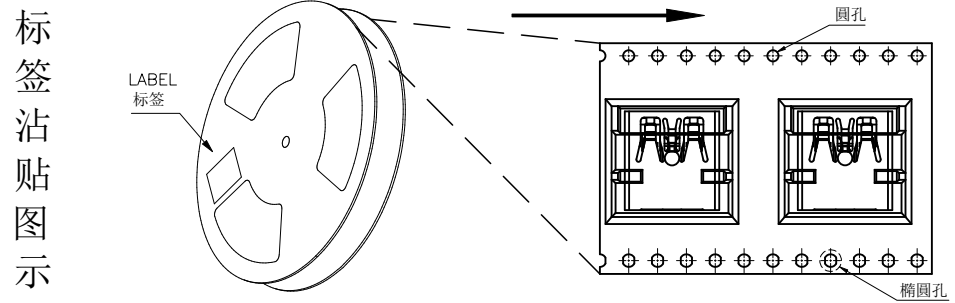
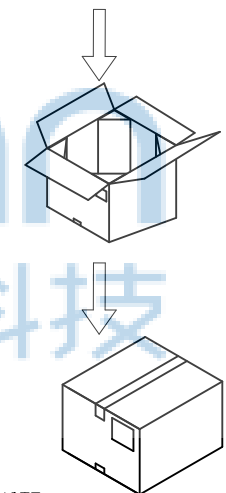
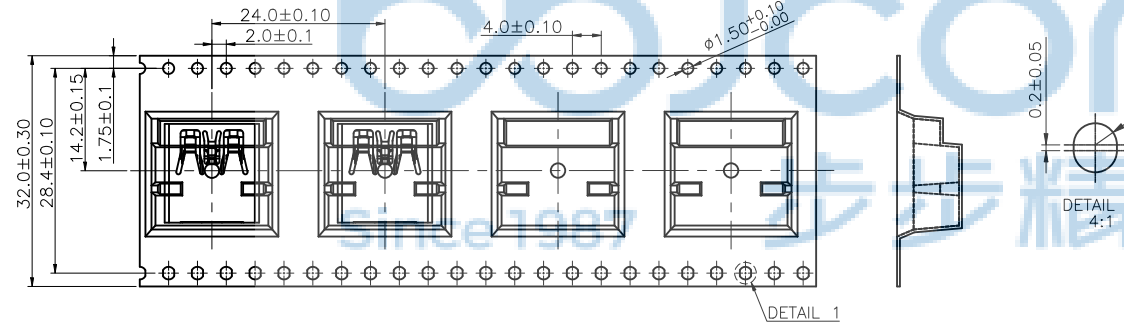
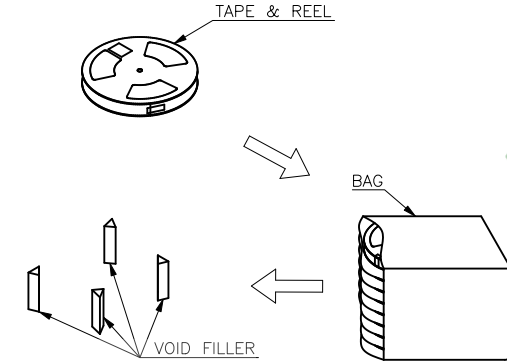
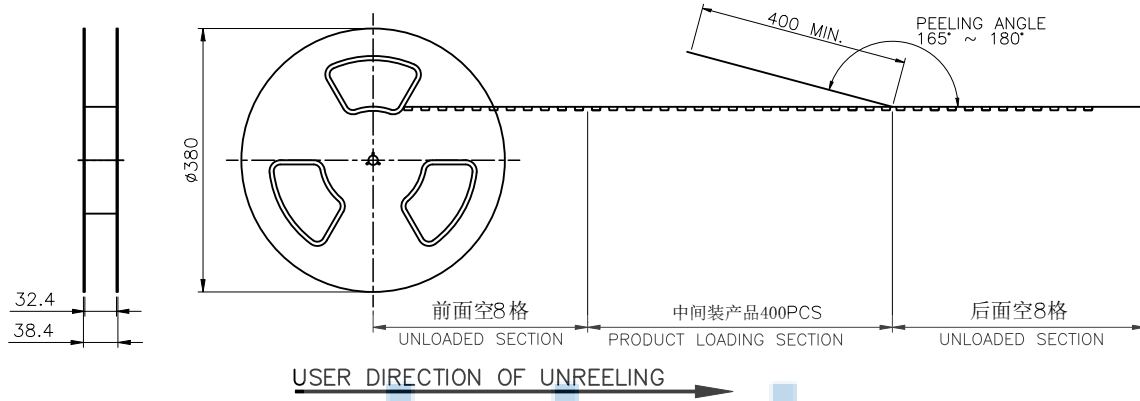

标签  
沾贴  
图  
示

NOTE:

- MATERIAL:  
BOX: FIBREBOARD, CORRUGATED, DOUBLE WALL.  
TAPE: POLYSTYRENES, HEAT-RESISTANT TEMPERATURE: 120°C, transparent color(透明色) COLOR.  
REEL: POLYSTYRENES, HEAT-RESISTANT TEMPERATURE: 70°C, BLUE COLOR.  
BAG: POLYETHYLENE, HEAT-RESISTANT TEMPERATURE: 100°C.
- PEELING STRENGTH: 0.1 ~ 1.3 N (10 ~ 130 GRAMS)
- PEELING SPEED: 300 mm/min.
- EACH BAG SHALL BE INCLUDED DESICCANT.

400	10	4000 PCS	-- KG	-- KG
PCS/ REEL	REELS/ CARTON	QUANTITY	GROSS WEIGHT	NET WEIGHT

THIS DOCUMENT IS THE SOLE PROPERTY OF BBJconn Technology Co.,Ltd. Corporation AND SHOULD NOT BE USED IN WHOLE OR IN PART WITHOUT PRIOR WRITTEN PERMISSION.

PDWG.NO: 0886-1

**深圳市步步精科技有限公司**

.X:  $\pm 0.38$  X':  $\pm 3'$   
.XX:  $\pm 0.25$  .X':  $\pm 2'$   
.XXX:  $\pm 0.13$  .XX':  $\pm 1'$

NAME: USB 3.0 A母 90度 DIP 四脚插 直脚 锡脚长1.80 平口 不锈钢外壳 LCP蓝胶 L=13.70 H=6.26 编带

APPD. JM\_Zheng

CHKD. LYX

DR. TSP

PJ. NO.: 127-275-090004-K4G

SIZE: A4 DRW NO.:

FINISH: SEE NOTES MAT'L.: SEE NOTES

SCALE: N/A REV.: A0 UNIT: mm PAGE: 2/2