

REV.	ECN NO.	CONTENT	DATE	ENGINEER
A0		Initial release	/	TSP

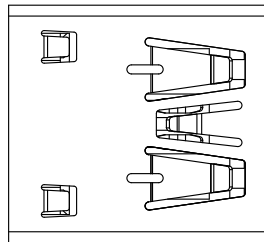
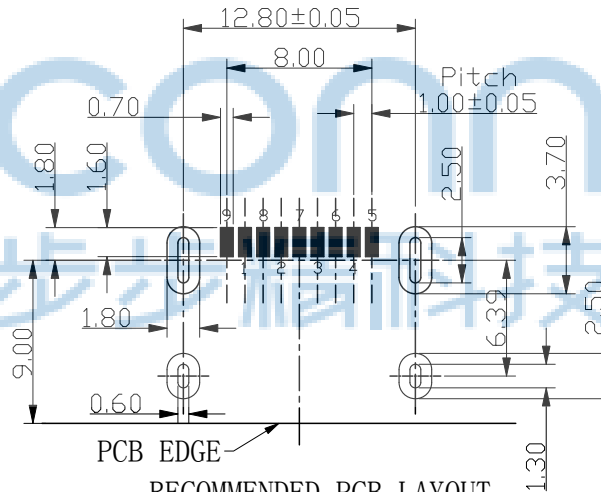
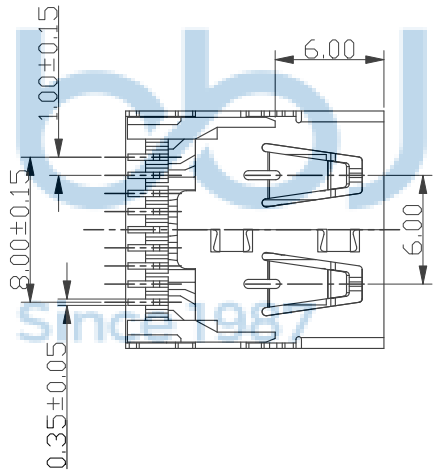
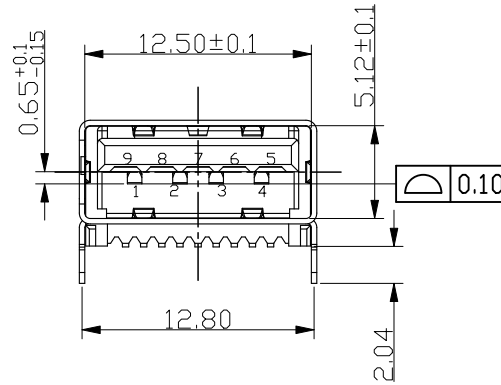
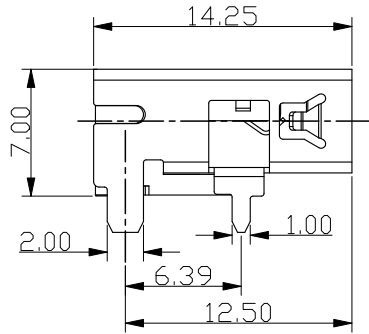
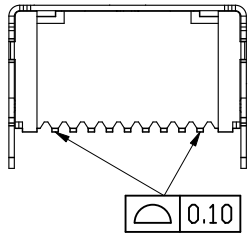

PCB EDGE
RECOMMENDED PCB LAYOUT
TOLERANCE: ±0.05mm

NOTE:

1. MATERIAL:

- 1.1 INSULATOR:HIGH TEMPERATURE PLASTIC LCP
- 1.2 CONTACT:BRONZE
- 1.3 SHELL:BRASS

2. ELECTRICAL CHARACTERISTICS:

- 2.1 CONTACT RESISTANCE:30mΩ MAXIMUM
- 2.2 CONTACT CURRENT RATING:1.5A
- 2.3 DIELECTRIC WITHSTANDING VOLTAGE:100 V AC R. M. S.
- 2.4 INSULATION RESISTANCE 100 MEGOHMS MIN
- 2.5 OPERATING TEMPERATURE:-40° C ~ 85° C

3. MECHANICAL CHARACTERISTICS:

- 3.1 MATING FORCE:3.57kgf MAX
- 3.2 UNMATED FORCE:0.82kgf MIN AFTER TEST
- 3.3 DURABILITY MANDATORY:1500 CYCLES

4. PLATING

4.1 TERMINAL:

- 50u" MIN NICKEL ALL OVER
- 80u"MIN Tin ON SOLDER AREA
- Au G/F ON CONTACT AREA

4.2 SHELL:50u"MIN. NICEL ALL OVER



Pin NUMBER	SIGNAL NAME
1	VBUS
2	D-
3	D+
4	GND
5	StdA_SSRX-
6	StdA_SSRX+
7	GND_DRAIN
8	StdA_SSTX-
9	StdA_SSTX+
Shell	Shield



THIS DOCUMENT IS THE SOLE PROPERTY OF BBJconn Technology Co.,Ltd. Corporation AND SHOULD NOT BE USED IN WHOLE OR IN PART WITHOUT PRIOR WRITTEN PERMISSION.		深圳市步步精科技有限公司	
.X: ±0.38 X° :±3° .XX: ±0.25 .X° :±2° .XXX: ±0.13 .XX° :±1°		NAME: USB 3.0 A母 90度 短体 SMT 四脚插 平口 铜壳 LCP蓝胶 L=14.25 编带	
APPD.	JM_Zheng	P.J. NO. : SIZE: A4 DRW NO. :	
CHKD.	LYX	FINISH: SEE NOTES MAT' L. : SEE NOTES	
PDWG.NO:	0886-1	SCALE: N/A	REV.: A0 UNIT: mm PAGE: 1/2



REV.	ECN NO.	CONTENT	DATE	ENGINEER
A0		Initial release	/	TSP

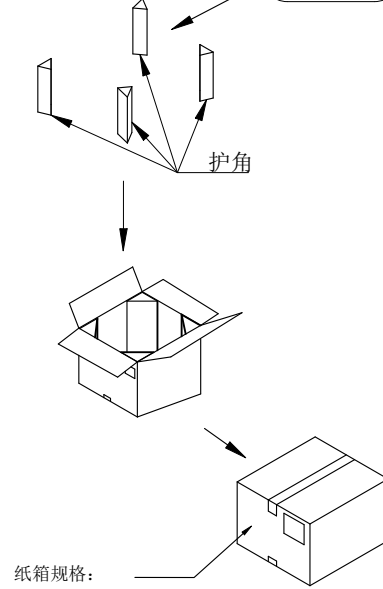
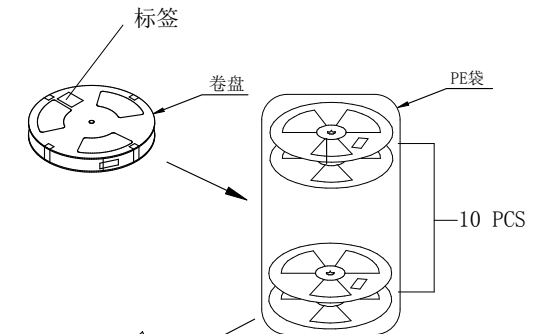
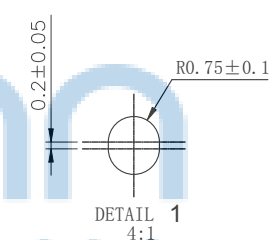
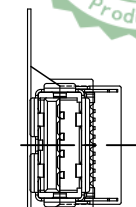
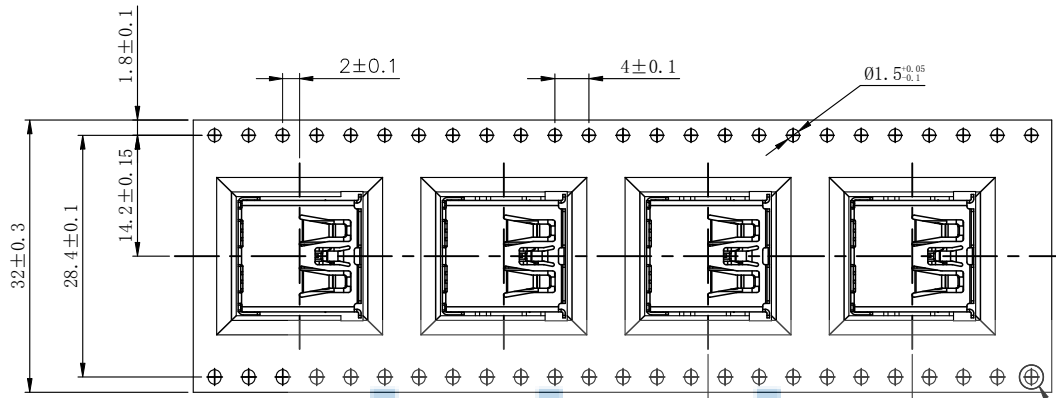

纸箱规格: 400*400*400

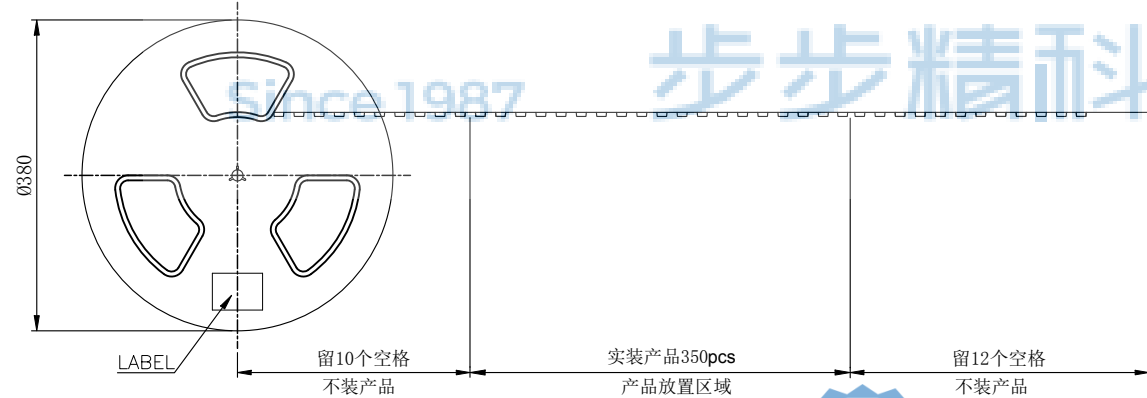
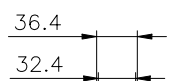

放料方向 →



NOTE:

- MATERIAL:
 - BOX: FIBREBOARD, CORRUGATED, DOUBLE WALL.
 - TAPE: POLYSTYRENES, HEAT-RESISTANT TEMPERATURE: 120°C, 透明 COLOR.
 - REEL: POLYSTYRENES, HEAT-RESISTANT TEMPERATURE: 70°C, BLUE COLOR.
 - BAG: POLYETHYLENE, HEAT-RESISTANT TEMPERATURE: 100°C.
- PEELING STRENGTH: 0.1 ~ 1.3 N (10 ~ 130 GRAMS)
- PEELING SPEED: 300 mm/min.
- EACH BAG SHALL BE INCLUDED DESICCANT.

350	10	3500 PCS	-- KG	-- KG
PCS/ REEL	REELS/ CARTON	QUANTITY	GROSS WEIGHT	NET WEIGHT

THIS DOCUMENT IS THE SOLE PROPERTY OF BBJconn Technology Co.,Ltd Corporation AND SHOULD NOT BE USED IN WHOLE OR IN PART WITHOUT PRIOR WRITTEN PERMISSION.

PDWG.NO: 0886-1

APPD. JM_Zheng
CHKD. LYX
DR. TSP

深圳市步步精科技有限公司

NAME: USB 3.0 A母 90度 短体 SMT 四脚插 平口 铜壳 LCP蓝胶 L=14.25 编带

PJ. NO. :
SIZE: A4 DRW NO. :
FINISH: SEE NOTES MAT' L. : SEE NOTES
SCALE: N/A REV. : A0 UNIT: mm PAGE: 2/2