

REV.	ECN NO.	CONTENT	DATE	ENGINEER
A0		Initial release	/	TSP

NOTE:
 1. MATERIAL:
 1.1 INSULATOR:HIGH TEMPERATURE PLASTIC LCP/PA9T
 1.2 CONTACT:BRONZE
 1.3 SHELL:BRASS
 2. ELECTRICAL CHARACTERISTICS:
 2.1 CONTACT RESISTANCE:30mΩ MAX
 2.2 CONTACT CURRENT RATING:1.5A
 2.3 DIELECTRIC WITHSTANDING VOLTAGE:100 V R. M. S.
 2.4 INSULATION RESISTANCE 100 MΩ MIN
 2.5 OPERATING TEMPERATURE:-40° C ~ 85° C
 3. MECHANICAL CHARACTERISTICS:
 3.1 MATING FORCE:3.57kgf MAX
 3.2 UNMATING FORCE:1.02kgf MIN
 3.3 DURABILITY:MANDATORY:1,500 CYCLES
 4. PLATING
 4.1 TERMINAL:
 50u" MIN NICKEL
 8u"MIN Tin ON SOLDER AREA
 Au G/F ON CONTACT AREA
 4.2 SHELL:50u"MIN. NICEL

DIMA
2.10
2.30
2.50

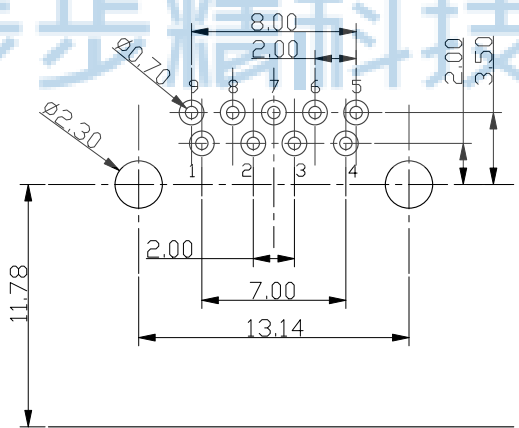
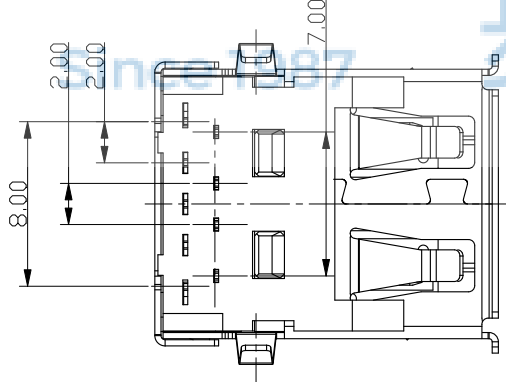
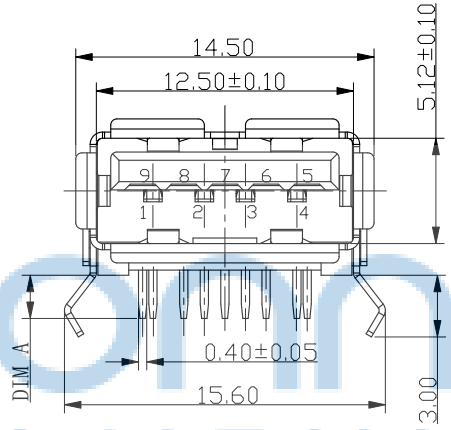
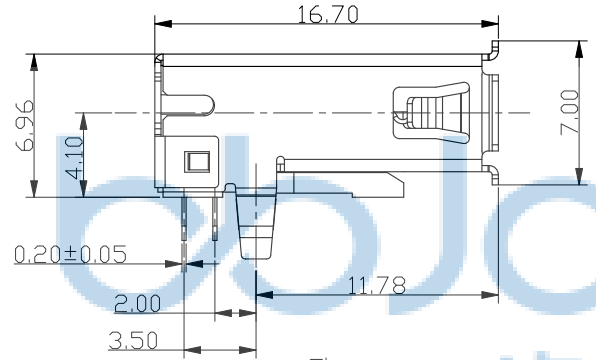
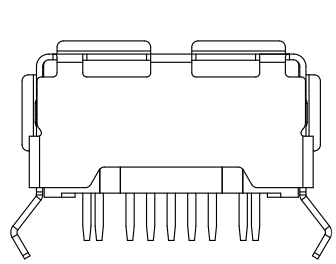
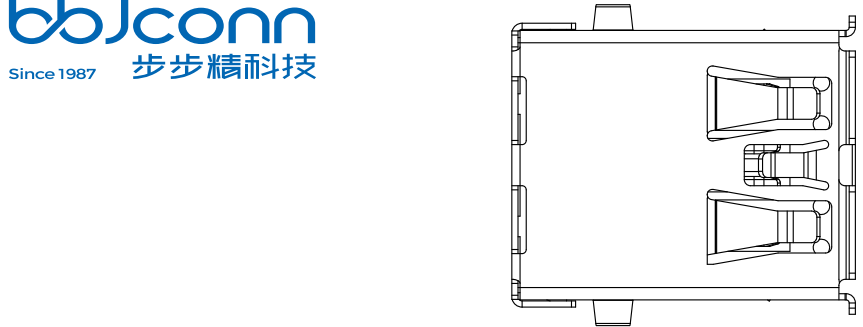

Pin NUMBER	SIGNAL NAME
1	VBUS
2	D-
3	D+
4	GND
5	StdA_SSRX-
6	StdA_SSRX+
7	GND_DRAIN
8	StdA_SSTX-
9	StdA_SSTX+
Shell	Shield

RECOMMENDED PCBA LAYOUT
(TOLERANCE ± 0.05)

THIS DOCUMENT IS THE SOLE PROPERTY OF BBJconn Technology Co.,Ltd. Corporation AND SHOULD NOT BE USED IN WHOLE OR IN PART WITHOUT PRIOR WRITTEN PERMISSION.		深圳市步步精科技有限公司	
.X: ±0.38 X° :±3° .XX: ±0.25 .X° :±2° .XXX: ±0.13 .XX° :±1°		NAME: USB 3.0 A母 90度 DIP 镀金GF 端子脚长2.30 后两脚插 弯脚 卷边 铜壳 LCP蓝胶 L=16.70	
APPD.	JM_Zheng	P.J. NO. : 127-272-090013-K4G SIZE: A4 DRW NO. :	FINISH: SEE NOTES MAT' L. : SEE NOTES SCALE: N/A REV. : A0 UNIT: mm PAGE: 1/2
CHKD.	LYX		
PDWG.NO:	0886-1	DR.	TSP

Packing Operation Standard

REV.	ECN NO.	CONTENT	DATE	ENGINEER
A0		Initial release	/	TSP



包装作业图示及说明 (PACKING OPERATION DIAGRAM & INSTRUCTION)

- 一:
- 1) 将成品一一放入包装盘内, 依同一方向放入.
 - 2) 一个包装盘放置100个成品, 盖上托盖上盖,
 - 3) 依次往上叠放10盘, 产品方向保持一致, 下面用一块纸板. 用保鲜膜将托盘两边缠绕 (保鲜膜距托盘边约50mm) 再在托盘中间缠绕成工字形, (缠绕3~5圈. 用力要适当)
- 二:
- 1) 一个纸箱放置2扎, 每扎10盘 (1000个成品)
 - 2) 将缠绕好的成品方入纸箱内, 再放2包干燥剂,
 - 3) 用透明胶将纸箱封实.
 - 4) 将标签 (按要求打印好的, 或客户提供) 贴在纸箱侧麦上方.

备

注 (REMARK)

- 1) 装不满一个外箱的, 用纸壳填满未滿空间. 或将纸箱割小至刚好装下.
 - 2) 在搬运过程中要轻拿轻放.
 - 3) 在运输中不可堆放过多, 不可有重压现象.
 - 4) 跌落测试条件: 成品箱子从1.5米高自由落体: (三棱六面一角)
- 检验项目: 1. 产品不可跑出包装盘凹槽.
2. 产品不可有摔伤, 变形.
3. 外箱及内包装材料不可严重破损.

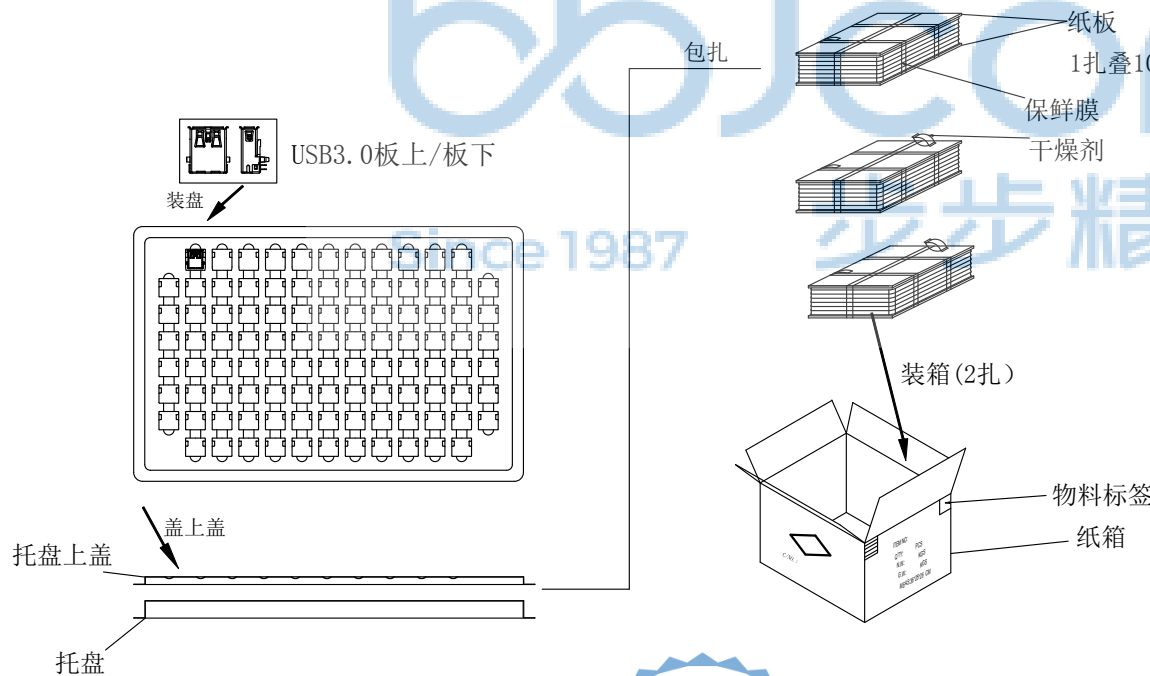

产品	SMT&DIP	2k
透明胶	W=47	若干
保鲜膜	W=62	若干
干燥剂	1g	2包
托盘上盖		20
托盘		20
纸箱	330*235*260	1
品名	规格 (mm)	用量 (PCS)



THIS DOCUMENT IS THE SOLE PROPERTY OF BBJconn Technology Co., Ltd. Corporation AND SHOULD NOT BE USED IN WHOLE OR IN PART WITHOUT PRIOR WRITTEN PERMISSION.
PDWG.NO: 0886-1

深圳市步步精科技有限公司

NAME: USB 3.0 A母 90度 DIP 镀金GF 端子脚长2.30 后两脚插 弯脚 卷边 铜壳 LCP蓝胶 L=16.70
 APPD. JM_Zheng
 CHKD. LYX
 DR. TSP
 P.J. NO.: 127-272-090013-K4G
 SIZE: A4 DRW NO.:
 FINISH: SEE NOTES MAT'L.: SEE NOTES
 SCALE: N/A REV.: A0 UNIT: mm PAGE: 2/2