

REV	ECN NO	CONTENT	DATE	ENGINEER
A0		INITIAL RELEASE	/	SGF

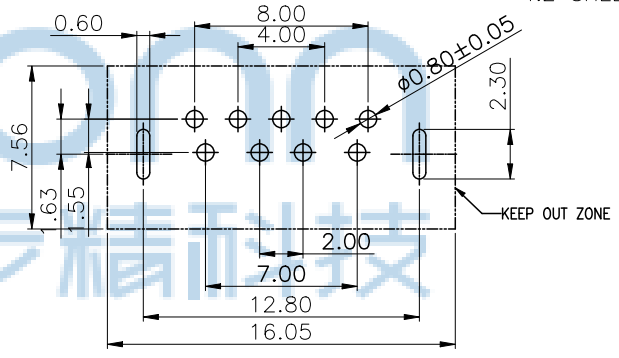

NOTE:
 1.MATERIAL:
 1.1 INSULATOR:HIGH TEMPERATURE PLASTIC
 1.2 CONTACT:BRONZE
 1.3 SHELL:STAINLESS STEEL
 2.ELECTRICAL CHARACTERISTICS;
 2.1 CONTACTRESISTANCE:30mΩ MAX
 2.2 CONTACT CURRENT RATING:1.5A
 2.3 DIELECTRIC WITHSTANDING VOLTAGE:100 V R.M.S.
 2.4 INSULATION RESISTANCE 100 MΩ MIN
 2.5 OPERATING TEMPERATURE:-40°C ~ 85°C
 3 MECHANICAL CHARACTERISTICS:
 3.1 MATING FORCE:3.57kgf MAX
 3.2 UNMATING FORCE:1.02kgf MIN
 3.3 DURABILITY:MANDATORY:1,500 CYCLES
 4.PLATING
 4.1 TERMINAL:
 50u" MIN NICKEL ALL OVER
 80u"MIN Tin ON SOLDER AREA
 (1~30)u"Au ON CONTACT AREA
 4.2 SHELL:50u"MIN.NICEL ALL OVER

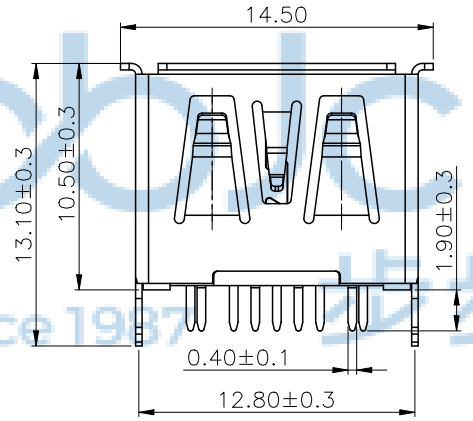
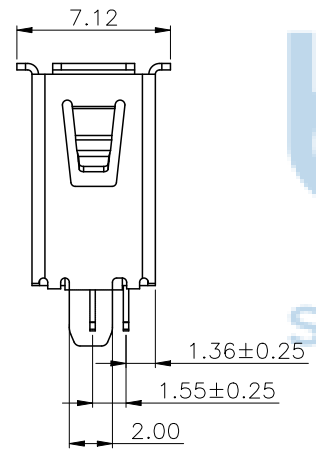
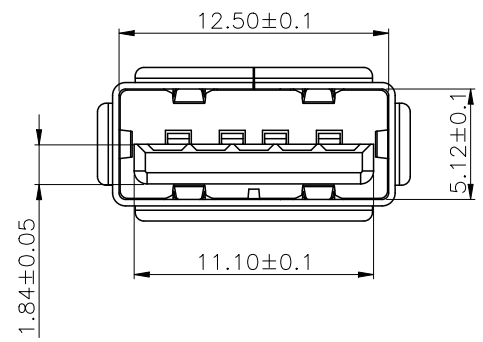

Recommended PCB Layout
 PCB Thickness=1.8±0.1mm

Pin NUMBER	SIGNAL NAME
1	VBUS
2	D-
3	D+
4	GND
5	StdA_SSRX-
6	StdA_SSRX+
7	GND_DRAIN
8	StdA_SSTX-
9	StdA_SSTX+
Shell	Shield

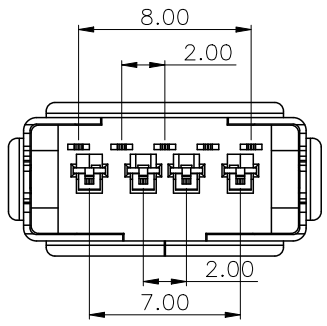

THIS DOCUMENT IS THE SOLE PROPERTY OF BBJconn Technology Co.,Ltd. Corporation AND SHOULD NOT BE USED IN WHOLE PRIOR WRITTEN PERMISSION.

PDWG NO: 0886-1

深圳市步步精科技有限公司

.X: ±0.38 X': ±3"
 .XX: ±0.25 X'': ±2"
 .XXX: ±0.13 .XX': ±1"

NAME: USB 3.0 AF 9P 180度 两脚插 端子DIP
 卷边 H=10.50 不锈钢外壳 LCP黑胶 盒装

APPD	JM_Zheng		PJ NO: 127-275-090010-K4G
CHKD	LYX		SIZE:A4 DRW NO:
DR	SGF	FINISH:SEE NOTES	MAT'L:SEE NOTES
		SCALE:N/A	REV:A0 UNIT:mm PAGE:1/2

- 一：
- 1) 将成品一一放入包装盘内, 依同一方向放入.
 - 2) 包装时, 依图所示.
 - 3) 一个吸塑盘放置100个成品.
 - 4) 依次往上叠放10盘, 产品方向保持一致, 用PE膜将托盘两边缠绕 (PE鲜膜距托盘边约50mm) 再在托盘中间缠绕成十字形为一扎, (缠绕3~5圈. 用力要适当)

- 二：
- 1) 将两扎托盘并排放入纸箱中. 并依次在上面并排叠放一扎/10盘, 一扎/5盘 总共6扎 (4扎/每扎10盘) (2扎/每扎5盘)
 - 2) 纸箱内放2包干燥剂
 - 3) 每箱装5000PCS成品

- 三：
- 1) 用透明胶将纸箱封实.
 - 2) 将标签 (按要求打印好的) 贴在纸箱侧麦上方.

标签粘贴处

ITEM NO:
Q'TY: PCS
N.W: KGS
G.W: KGS
MEAS: 47.5X25.5X21CM

C/N0:
MADE IN CHINA

备 注 (REMARK)

- 1) 装不满一个外箱的, 用填充物填满未空间或将纸箱割小至刚好装下.
- 2) 在搬运过程中要轻拿轻放.
- 3) 在运输中不可堆放过多, 不可有重压现象.

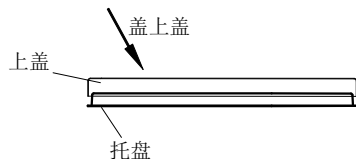
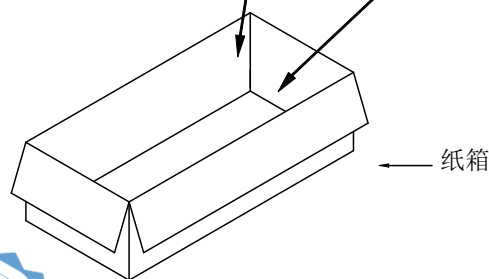
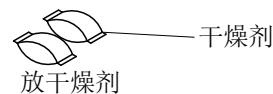
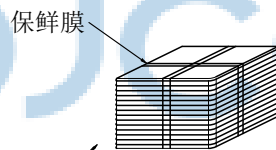
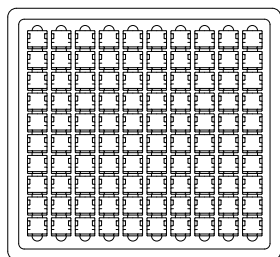

产品	直立式H=11.5	5000
透明胶	W=47	若干
PE膜	W=68	若干
干燥剂	1.2g/包	2包
托盘	225*225*9	50
纸箱	475*255*210	1
品名	规格 (mm)	用量 (PCS)

THIS DOCUMENT IS THE
SOLE PROPERTY OF
BBJconn Technology Co.,Ltd.
Corporation AND SHOULD
NOT BE USED IN WHOLE
PRIOR WRITTEN PERMISSION.
PDWG NO: 0886-1

深圳市步步精科技有限公司

.X: ±0.38 X': ±3'
.XX: ±0.25 .X': ±2'
.XXX: ±0.13 .XX': ±1'

NAME: USB 3.0 AF 9P 180度 两脚插 端子DIP
卷边 H=10.50 不锈钢外壳 LCP黑胶 盒装

APPD JM_Zheng
CHKD LYX
DR SGF

PJ NO: 127-275-090010-K4G
SIZE:A4 DRW NO:
FINISH:SEE NOTES MAT'L:SEE NOTES
SCALE:N/A REV:AO UNIT:mm PAGE:2/2