

REV.	ECN NO.	CONTENT	DATE	ENGINEER
A0		Initial release	/	TSP

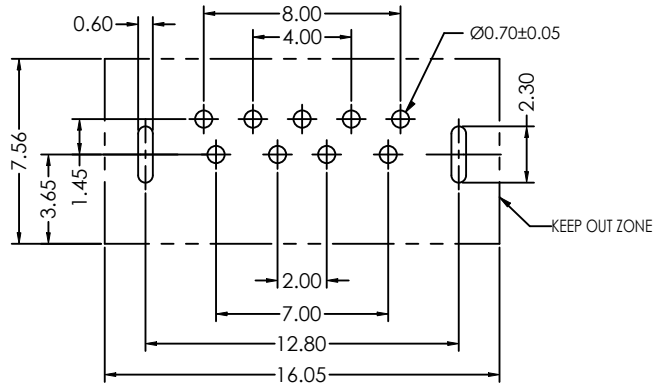

Recommended PCB Layout
PCB Thickness=1.8±0.1mm

NOTE:
 1. MATERIAL:
 1.1 INSULATOR:HIGH TEMPERATURE PLASTIC LCP
 1.2 CONTACT:BRONZE
 1.3 SHELL:BRASS
 2. ELECTRICAL CHARACTERISTICS;
 2.1 CONTACT RESISTANCE:30mΩ MAX
 2.2 CONTACT CURRENT RATING:1.5A
 2.3 DIELECTRIC WITHSTANDING VOLTAGE:100 V R. M. S.
 2.4 INSULATION RESISTANCE 100 MΩ MIN
 2.5 OPERATING TEMPERATURE:-40° C ~ 85° C
 3 MECHANICAL CHARACTERISTICS:
 3.1 MATING FORCE:3.57kgf MAX
 3.2 UNMATING FORCE:1.02kgf MIN
 3.3 DURABILITY:MANDATORY:1,500 CYCLES
 4. PLATING
 4.1 TERMINAL:
 50u" MIN NICKEL ALL OVER
 120u" MIN Tin ON SOLDER AREA
 Au G/F ON CONTACT AREA
 4.2 SHELL:50u" MIN. NICEL ALL OVER

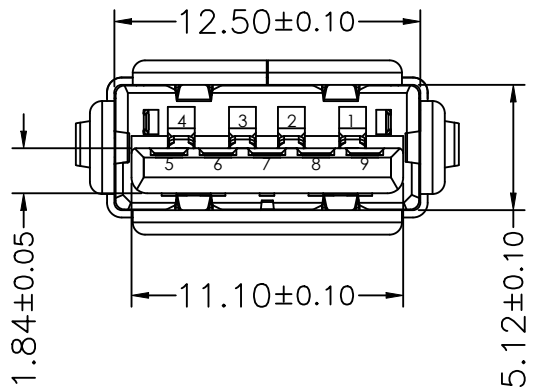
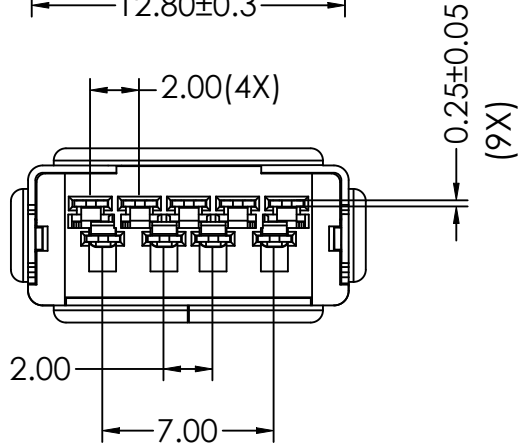
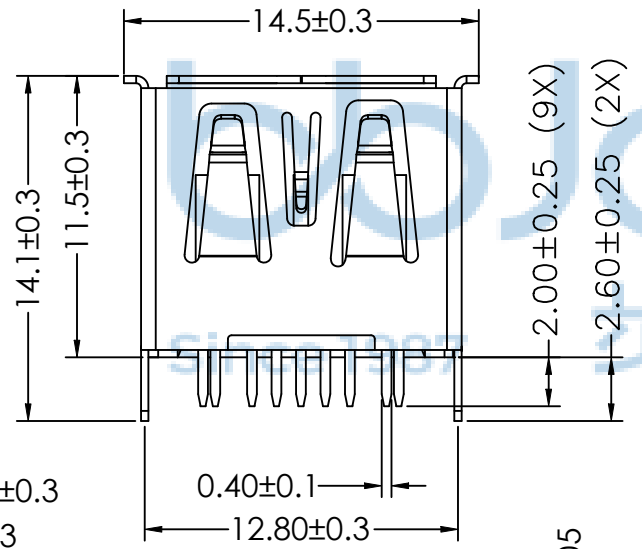
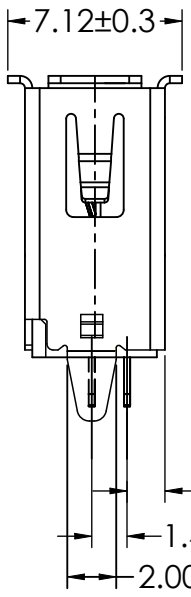

Pin NUMBER	SIGNAL NAME
1	VBUS
2	D-
3	D+
4	GND
5	StdA_SSRX-
6	StdA_SSRX+
7	GND_DRAIN
8	StdA_SSTX-
9	StdA_SSTX+
Shell	Shield



THIS DOCUMENT IS THE SOLE PROPERTY OF BBJconn Technology Co.,Ltd. Corporation AND SHOULD NOT BE USED IN WHOLE OR IN PART WITHOUT PRIOR WRITTEN PERMISSION.
 PDWG.NO: 0886-1

深圳市步步精科技有限公司

.X: ±0.38	X': ±3'	NAME: USB 3.0 A母 180度 DIP 两脚插 直脚 卷边 铜壳 LCP黑胶 H=11.50 编带
.XX: ±0.25	.X': ±2'	
.XXX: ±0.13	.XX': ±1'	
APPD: JM_Zheng		PJ. NO.: 127-275-090017-K4G
CHKD: LYX		SIZE: A4 DRW NO.:
DR: TSP		FINISH: SEE NOTES MAT'L: SEE NOTES
		SCALE: N/A REV.: A0 UNIT: mm PAGE: 1/2

REV.	ECN NO.	CONTENT	DATE	ENGINEER
A0		Initial release	/	TSP

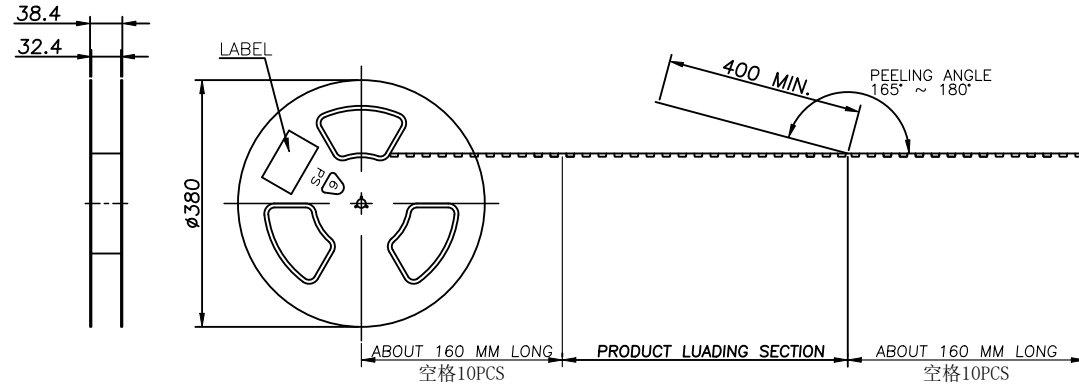

- NOTE:
- MATERIAL:
BOX: FIBREBOARD, CORRUGATED, DOUBLE WALL.
TAPE: POLYSTYRENES, HEAT-RESISTANT TEMPERATURE: 120°C, Transparent COLOR.
REEL: POLYSTYRENES, HEAT-RESISTANT TEMPERATURE: 70°C, BLUE COLOR.
BAG: POLYETHYLENE, HEAT-RESISTANT TEMPERATURE: 100°C.
 - PEELING STRENGTH: 0.1 ~ 1.3 N (10 ~ 130 GRAMS)
 - PEELING SPEED: 300 mm/min.
 - EACH BAG SHALL BE INCLUDED DESICCANT.

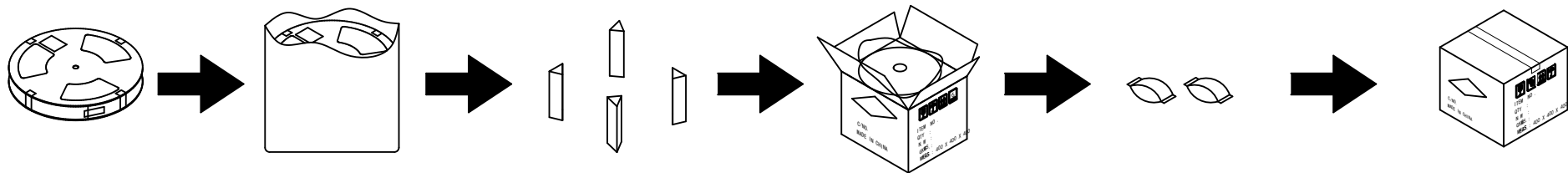
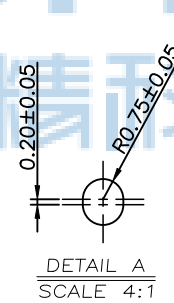
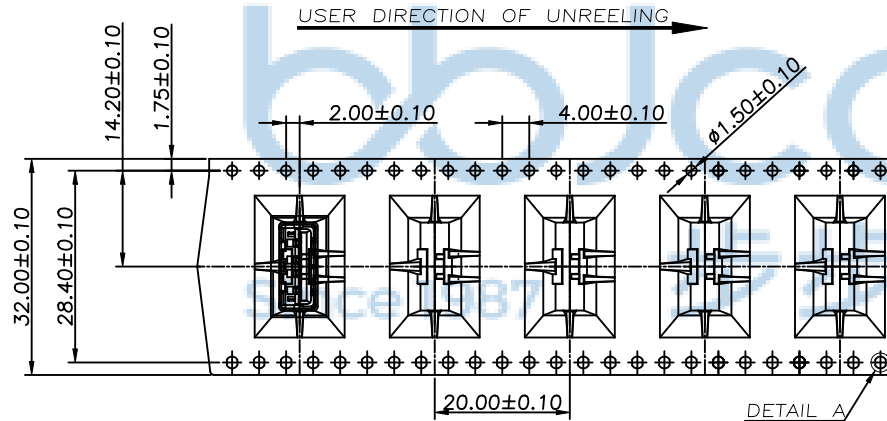

Each reels contains 280 PCS Each bag contains 10 reels Put 4PCS corner protector in each box Put 10PCS rolls in each box Put 2PCS desiccant in each box Box dimensions:400 X 400 X 400



280 PCS	10 R	2800 PCS	-- KG	-- KG
PSC/Reel	Reel/CARTON	QUANTITY	CROSS WEIGHT	NET WEIGHT

THIS DOCUMENT IS THE SOLE PROPERTY OF BBJconn Technology Co.,Ltd. Corporation AND SHOULD NOT BE USED IN WHOLE OR IN PART WITHOUT PRIOR WRITTEN PERMISSION. PDWG.NO: 0886-1

深圳市步步精科技有限公司

.X: ±0.38	X': ±3'	NAME: USB 3.0 A母 180度 DIP 两脚插 直脚 卷边 铜壳 LCP黑胶 H=11.50 编带
.XX: ±0.25	.X': ±2'	
.XXX: ±0.13	.XX': ±1'	
APPD: JM_Zheng		PJ. NO.: 127-275-090017-K4G
CHKD: LYX		SIZE: A4 DRW NO.:
DR: TSP		FINISH: SEE NOTES MAT'L.: SEE NOTES
		SCALE: N/A REV.: A0 UNIT: mm PAGE: 2/2