

REV.	ECN NO	CONTENT	DATE	ENGINEER
A0		Initial release	/	TSP

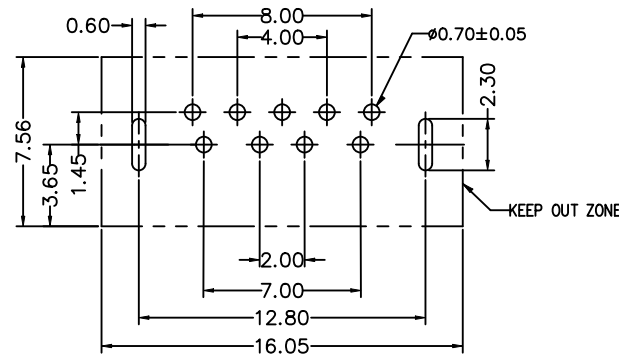

Recommended PCB Layout
PCB Thickness=1.8±0.1mm

NOTE:
1. MATERIAL:
1.1 INSULATOR:HIGH TEMPERATURE PLASTIC LCP
1.2 CONTACT:BRONZE
1.3 SHELL:BRASS
2. ELECTRICAL CHARACTERISTICS:
2.1 CONTACT RESISTANCE:30mΩ MAX
2.2 CONTACT CURRENT RATING:1.5A
2.3 DIELECTRIC WITHSTANDING VOLTAGE:100 V R. M. S.
2.4 INSULATION RESISTANCE 100 MΩ MIN
2.5 OPERATING TEMPERATURE:-40° C ~ 85° C
3 MECHANICAL CHARACTERISTICS:
3.1 MATING FORCE:3.57kgf MAX
3.2 UNMATING FORCE:1.02kgf MIN
3.3 DURABILITY:MANDATORY:1,500 CYCLES
4. PLATING
4.1 TERMINAL:
50u" MIN NICKEL
80u"MIN Tin ON SOLDER AREA
Au G/F ON CONTACT AREA
4.2 SHELL:50u"MIN. NICEL

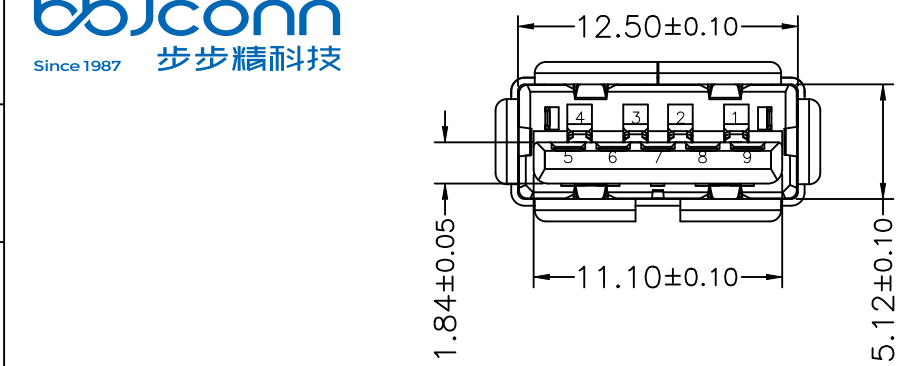
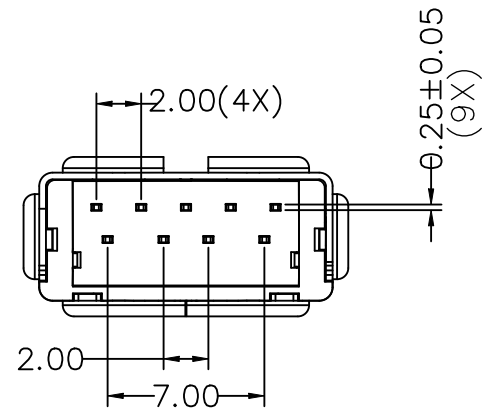
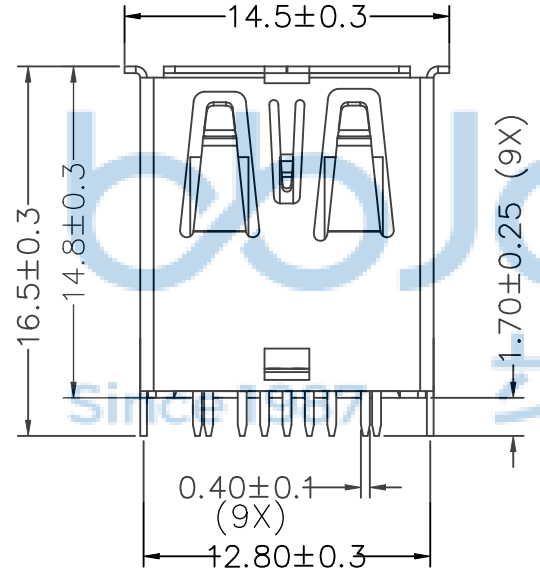
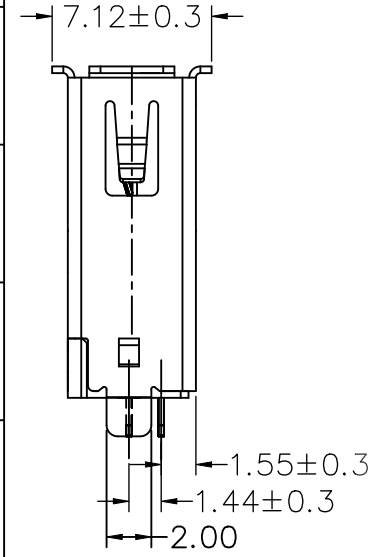

Pin NUMBER	SIGNAL NAME
1	VBUS
2	D-
3	D+
4	GND
5	StdA_SSRX-
6	StdA_SSRX+
7	GND_DRAIN
8	StdA_SSTX-
9	StdA_SSTX+
Shell	Shield



THIS DOCUMENT IS THE SOLE PROPERTY OF BBJconn Technology Co.,Ltd. Corporation AND SHOULD NOT BE USED IN WHOLE OR IN PART WITHOUT PRIOR WRITTEN PERMISSION.		深圳市步步精科技有限公司 .X: ±0.38 .X': ±3" .XX: ±0.25 .X'': ±2" .XXX: ±0.13 .X''': ±1"		NAME: USB 3.0 A母 180度 DIP 两脚插 直脚 外壳脚长1.7 卷边 不锈钢外壳 LCP蓝胶 H=14.80 盒装 APPD. JM_Zheng PJ. NO.: 127-275-090022-K4G CHKD. LYX SIZE: A4 DRW NO.: FINISH: SEE NOTES MAT'L.: SEE NOTES PDWG.NO: 0886-1 DR. TSP SCALE: N/A REV.: A0 UNIT: mm PAGE: 1/2	
--	--	---	--	--	--

包装作业图示及说明 (PACKING OPERATION DIAGRAM & INSTRUCTION)

一:

- 1) 将成品一一放入包装盘内, 依同一方向放入.
- 2) 包装时, 依图所示.
- 3) 一个吸塑盘放置100个成品.

4) 依次往上叠放15盘, 产品方向保持一致, 上下各放一块硬纸板, 用PE膜将托盘两边缠绕(PE鲜膜距托盘边约50mm) 再在托盘中间缠绕成#字形为一扎, (缠绕3~5圈. 用力要适当)

二:

- 1) 将2扎托盘按上下顺序放入纸箱中.
- 2) 纸箱内放2包干燥剂
- 3) 每箱装3000PCS成品

三:

- 1) 用透明胶将纸箱封实.
- 2) 将标签(按要求打印好的)贴在纸箱侧麦上方.

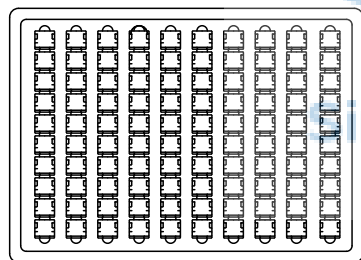
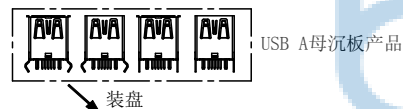

吸塑盒规格: 315mm*225mm*9mm

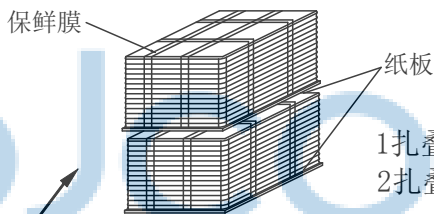

1扎叠15个成品托盘
2扎叠30个成品托盘

包山扎

装箱

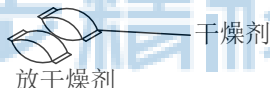

干燥剂

纸箱

标签粘贴处

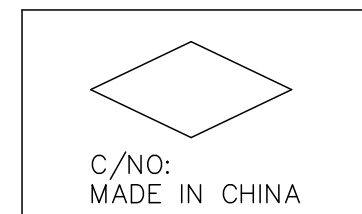
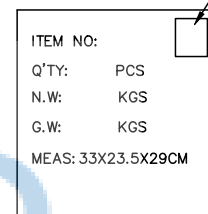

备注 (REMARK)

- 1) 装不满一个外箱的, 用填充物填满未装空间或将纸箱割小至刚好装下.
- 2) 在搬运过程中要轻拿轻放.
- 3) 在运输中不可堆放过多, 不可有重压现象.
- 4) 跌落测试条件: 成品箱子从1.0米高自由落体: (三棱六面一角)
检验项目: 1. 产品不可跑出包装盘凹槽.
2. 产品不可有摔伤, 变形.
3. 外箱及内包装材料不可严重破损.



产品	SMT&DIP	3000
透明胶	W=47	若干
PE膜	W=68	若干
干燥剂	1.2g/包	2包
纸板	314*224*3	2
托盘	315*225*9	30
纸箱	330*235*290	1
品名	规格(mm)	用量(PCS)

THIS DOCUMENT IS THE SOLE PROPERTY OF BBJconn Technology Co., Ltd. Corporation AND SHOULD NOT BE USED IN WHOLE OR IN PART WITHOUT PRIOR WRITTEN PERMISSION.		深圳市步步精科技有限公司	
PDWG.NO: 0886-1		.X: ±0.38 .XX: ±0.25 .XXX: ±0.13	X': ±3' .X': ±2' .XX': ±1'
APPD.	JM_Zheng	NAME: USB 3.0 A母 180度 DIP 两脚插 直脚 外壳脚长1.7 卷边 不锈钢外壳 LCP蓝胶 H=14.80 盒装	
CHKD.	LYX	PJ. NO.: 127-275-090022-K4G	
DR.	TSP	SIZE: A4 DRW NO.:	
		FINISH: SEE NOTES MAT'L.: SEE NOTES	
		SCALE: N/A REV.: A0 UNIT: mm PAGE: 2/2	