

REV.	ECN NO	CONTENT	DATE	ENGINEER
A0		Initial release	/	TSP

NOTES:

- MATERIAL:
  - 1.1 PLASTIC LCP , UL 94V-0, COLOR: BLACK
  - 1.2 CONTACT: C5191
  - 1.3 SHELL: STAINLESS STEEL
- FINISH:
  - 2.1 TERMINAL: 50u" MIN. NICKEL PLATED OVERALL
  - 2.2 CONTACT: SELECTIVE GOLD PLATED G/P,
  - 2.3 TAIL: 100u" MATT-TIN PLATED
  - 2.4 SHELL: 50u" MIN. NICKEL PLATED OVERALL

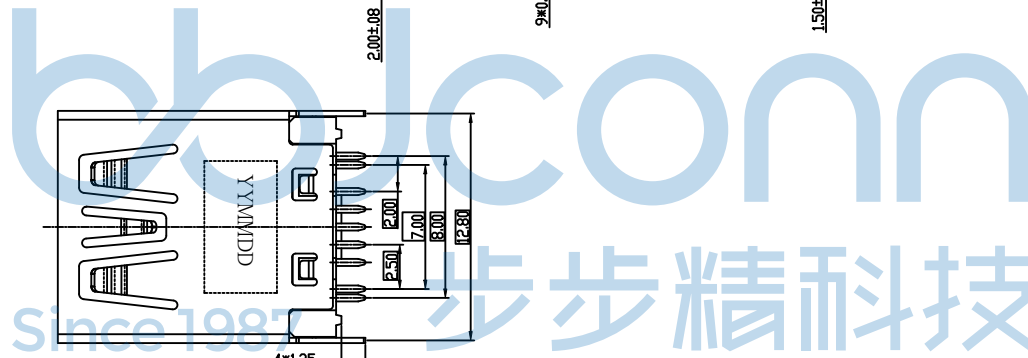
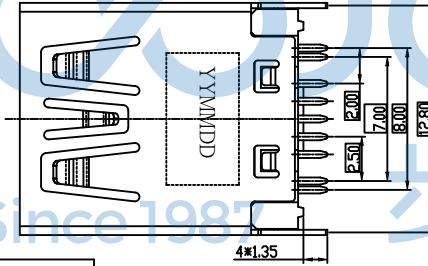
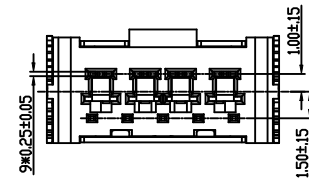
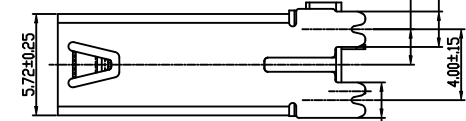
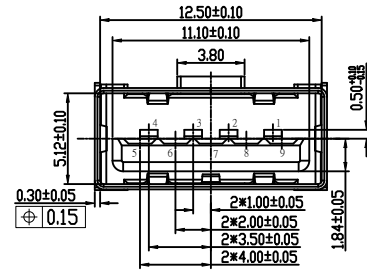
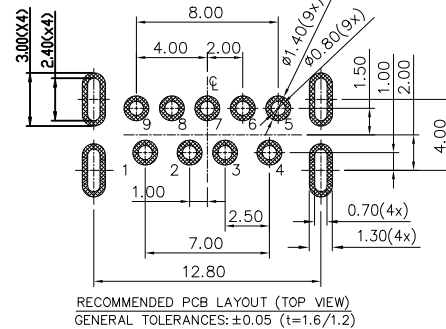
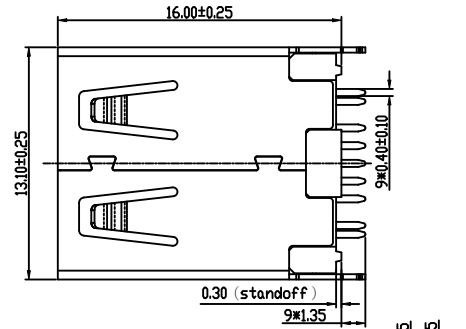

Pin NUMBER	SIGNAL NAME
1	VBUS
2	D-
3	D+
4	GND
5	StdA_SSRX-
6	StdA_SSRX+
7	GND_DRAIN
8	StdA_SSTX-
9	StdA_SSTX+
Shell	Shield

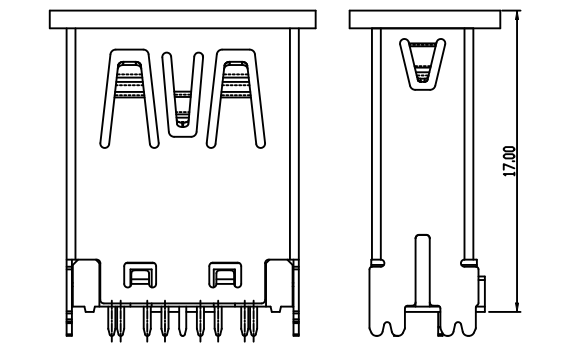
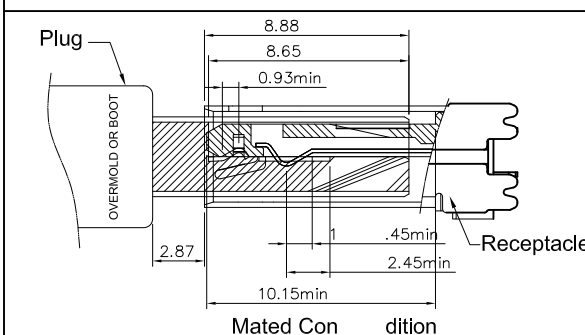
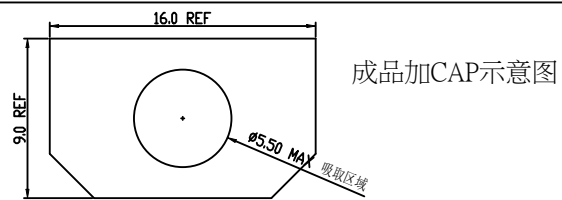

THIS DOCUMENT IS THE SOLE PROPERTY OF BBJconn Technology Co., Ltd Corporation AND SHOULD NOT BE USED IN WHOLE OR IN PART WITHOUT PRIOR WRITTEN PERMISSION.		深圳市步步精科技有限公司 APPD. JM_Zheng CHKD. LYX DR. TSP		NAME: USB 3.0 A母 180度 DIP 四脚插 GEN2版过10G 平口 不锈钢外壳 LCP黑胶 锡脚1.35 H=16.0 加盖编带 PJ. NO.: 127-275-090028-K4G SIZE: A4 DRW NO.: FINISH: SEE NOTES MAT'L.: SEE NOTES SCALE: N/A REV.: A0 UNIT: mm PAGE: 1/2	
PDWG.NO:	0886-1				

REV.	ECN NO	CONTENT	DATE	ENGINEER
A0		Initial release	/	TSP

- NOTE:
- MATERIAL:  
 BOX: FIBREBOARD, CORRUGATED, DOUBLE WALL.  
 TAPE: POLYSTYRENES, HEAT-RESISTANT TEMPERATURE: 120°C, Transparent COLOR.  
 REEL: POLYSTYRENES, HEAT-RESISTANT TEMPERATURE: 70°C, BLUE COLOR.  
 BAG: POLYETHYLENE, HEAT-RESISTANT TEMPERATURE: 100°C.
  - PEELING STRENGTH: 0.1 ~ 1.3 N (10 ~ 130 GRAMS)
  - PEELING SPEED: 300 mm/min.
  - EACH BAG SHALL BE INCLUDED DESICCANT.

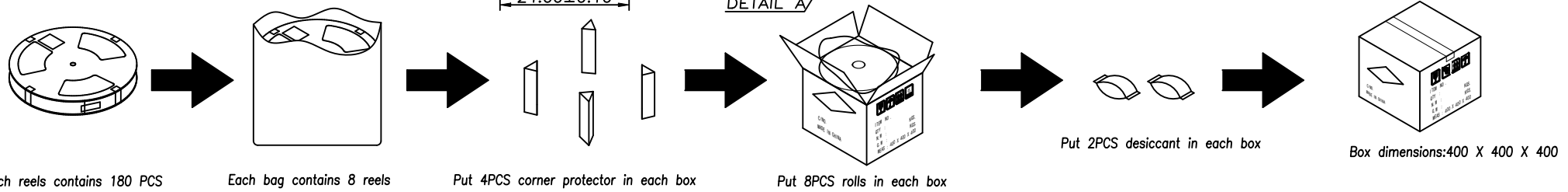
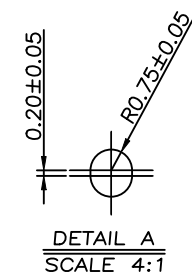
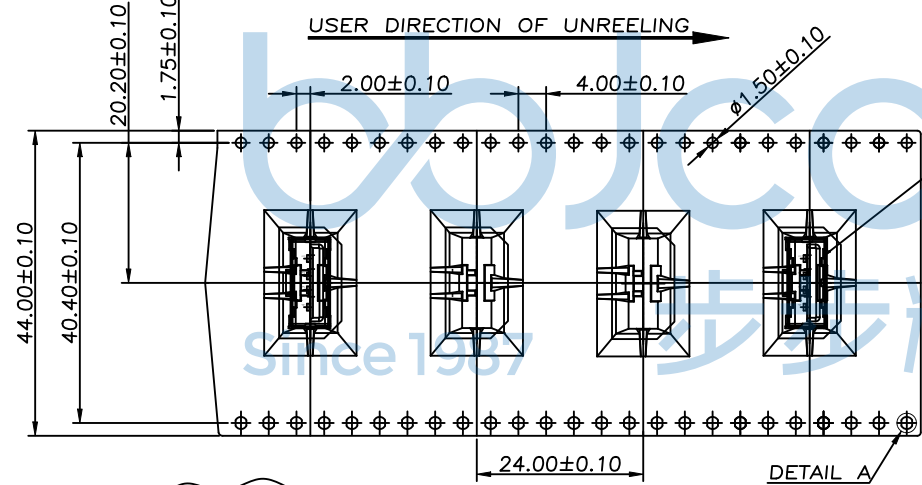
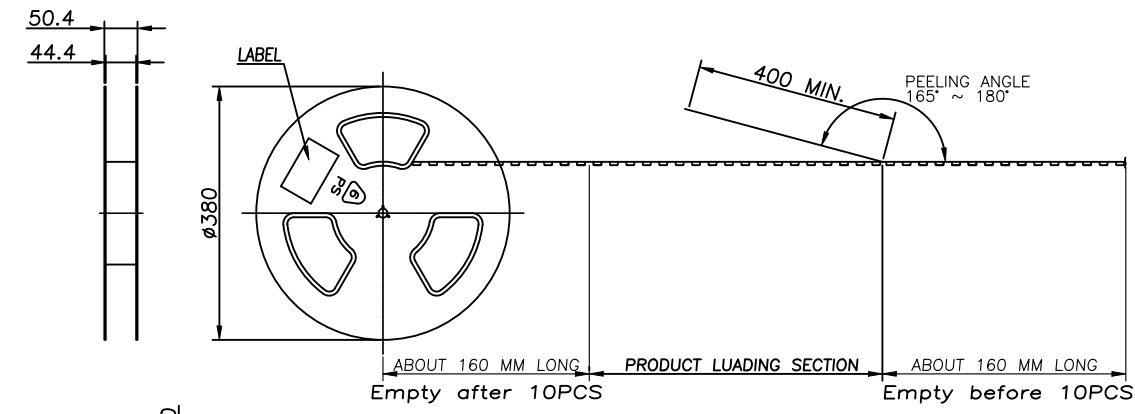

Each reels contains 180 PCS      Each bag contains 8 reels      Put 4PCS corner protector in each box      Put 8PCS rolls in each box

Put 2PCS desiccant in each box      Box dimensions:400 X 400 X 400

180 PCS	8 R	1440 PCS	-- KG	-- KG
PSC/Reel	Reel/CARTON	QUANTITY	CROSS WEIGHT	NET WEIGHT

THIS DOCUMENT IS THE SOLE PROPERTY OF BBJconn Technology Co.,Ltd Corporation AND SHOULD NOT BE USED IN WHOLE OR IN PART WITHOUT PRIOR WRITTEN PERMISSION.

PDWG.NO: 0886-1

APPD. JM\_Zheng

CHKD. LYX

DR. TSP

**深圳市步步精科技有限公司**

.X: ±0.38    .XX: ±0.25    .XXX: ±0.13

X\*: ±3"    .X\*: ±2"    .XX\*: ±1"

NAME: USB 3.0 A母 180度 DIP 四脚插 GEN2版过10G 平口 不锈钢外壳 LCP黑胶 锡脚1.35 H=16.0 加盖编带

PJ. NO.: 127-275-090028-K4G

SIZE: A4 DRW NO.:

FINISH: SEE NOTES    MAT'L.: SEE NOTES

SCALE: N/A    REV.: A0    UNIT: mm    PAGE: 2/2