

REV.	ECN NO.	CONTENT	DATE	ENGINEER
A0		Initial release	/	GZY

NOTE:

- MATERIAL:
 - INSULATOR:LCP UL 94V-0
 - CONTACT:BRONZE
 - SHELL:BRASS
- ELECTRICAL CHARACTERISTICS:
 - CONTACT RESISTANCE:30mΩ MAXIMUM
 - CONTACT CURRENT RATING:1.5A
 - DIELECTRIC WITHSTANDING VOLTAGE:100 V AC R. M. S.
 - INSULATION RESISTANCE 100 MEGOHMS MIN
 - OPERATING TEMPERATURE:-40° C ~ 85° C
- MECHANICAL CHARACTERISTICS:
 - MATING FORCE:3.57kgf MAX
 - UNMATED FORCE:1.02kgf MIN AFTER TEST
 - DURABILITY MANDATORY:1500 CYCLES
- PLATING
 - TERMINAL:
 - 50u" MIN NICKEL
 - 80u"MIN Tin ON SOLDER AREA
 - (1~30)u"Au ON CONTACT AREA
 - SHELL:50u"MIN. NICEL

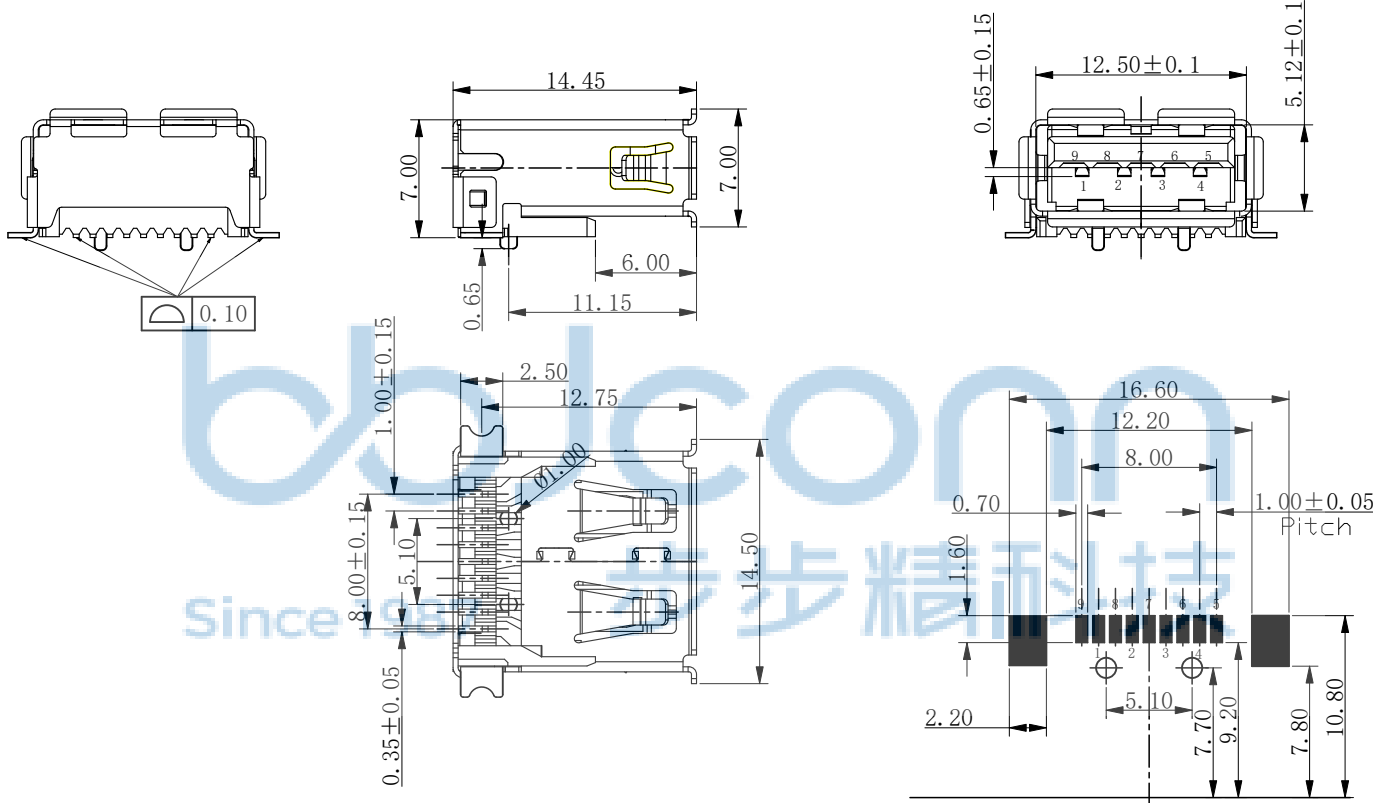

PCB EDGE
RECOMMENDED PCB LAYOUT



Pin NUMBER	SIGNAL NAME
1	VBUS
2	D-
3	D+
4	GND
5	StdA_SSRX-
6	StdA_SSRX+
7	GND_DRAIN
8	StdA_SSTX-
9	StdA_SSTX+
Shell	Shield

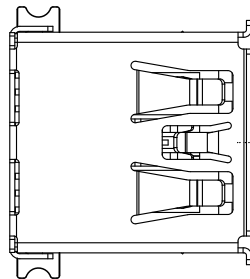

THIS DOCUMENT IS THE
SOLE PROPERTY OF
BBJconn Technology Co., Ltd.
Corporation AND SHOULD
NOT BE USED IN WHOLE
OR IN PART WITHOUT
PRIOR WRITTEN PERMISSION.
PDWG.NO: 0886-1



深圳市步步精科技有限公司

NAME: USB 3.0 AF 90度 短体 端子SMT 两脚贴 带柱 卷边 L=14.45 铜壳 编带		P.J. NO.: 127-271-090011-K4G	
APPD. JM_Zheng	CHKD. LYX	FINISH: SEE NOTES	MAT'L.: SEE NOTES
DR. GZY	SCALE: N/A	REV.: A0	UNIT: mm
			PAGE: 1/2



REV.	ECN NO.	CONTENT	DATE	ENGINEER
A0		Initial release	/	GZY

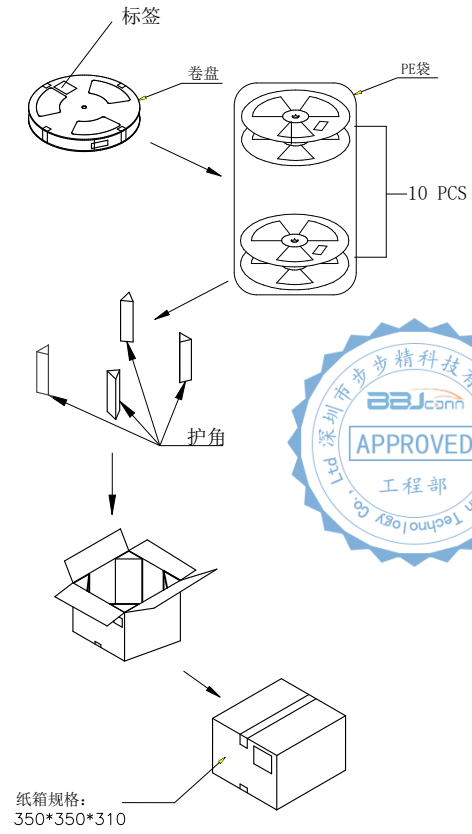
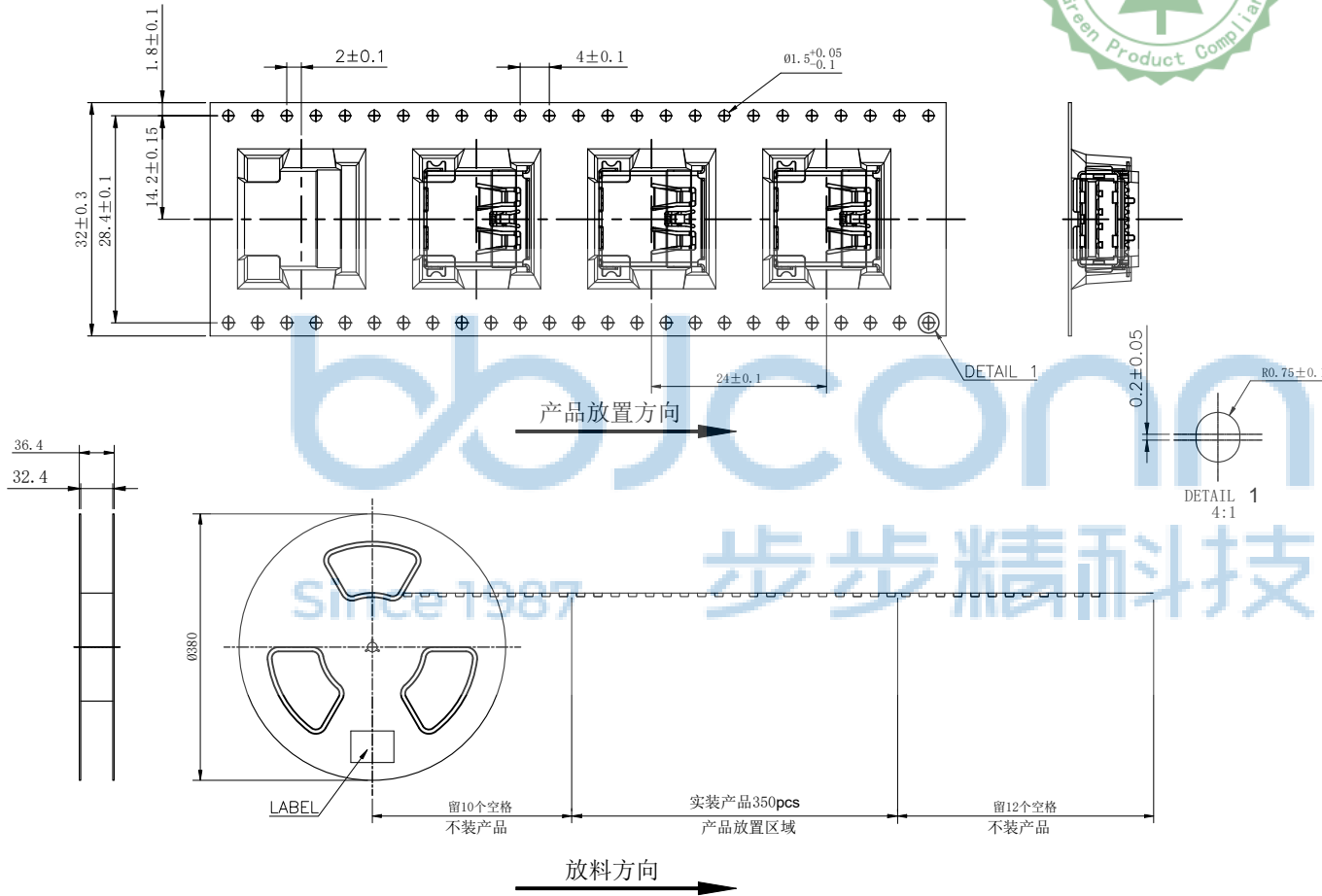

NOTE:

- MATERIAL:
BOX: FIBREBOARD, CORRUGATED, DOUBLE WALL
TAPE: POLYSTYRENES, HEAT-RESISTANT TEMPERATURE: 120°C, 透明 COLOR.
REEL: POLYSTYRENES, HEAT-RESISTANT TEMPERATURE: 70°C, BLUE COLOR.
BAG: POLYETHYLENE, HEAT-RESISTANT TEMPERATURE: 100°C.
- PEELING STRENGTH: 0.1 ~ 1.3 N (10 ~ 130 GRAMS)
- PEELING SPEED: 300 mm/min.
- EACH BAG SHALL BE INCLUDED DESICCANT.

THIS DOCUMENT IS THE SOLE PROPERTY OF BBJconn Technology Co., Ltd. Corporation AND SHOULD NOT BE USED IN WHOLE OR IN PART WITHOUT PRIOR WRITTEN PERMISSION. PDWG. NO: 0886-1	深圳市步步精科技有限公司 .X: ±0.38 X° :±3° .XX: ±0.25 .X° :±2° .XXX: ±0.13 .XX° :±1°		NAME: USB 3.0 AF 90度 短体 端子SMT 两脚贴 带柱 卷边 L=14.45 铜壳 编带	
			APPD. JM_Zheng P.J. NO.: 127-271-090011-K4G	
	CHKD. LYX		SIZE: A4 DRW NO.:	
	DR. GZY		FINISH: SEE NOTES MAT'L.: SEE NOTES	
			SCALE: N/A	REV.: A0