

REV	ECN NO	CONTENT	DATE	ENGINEER
A0		INITIAL RELEASE	/	SGF

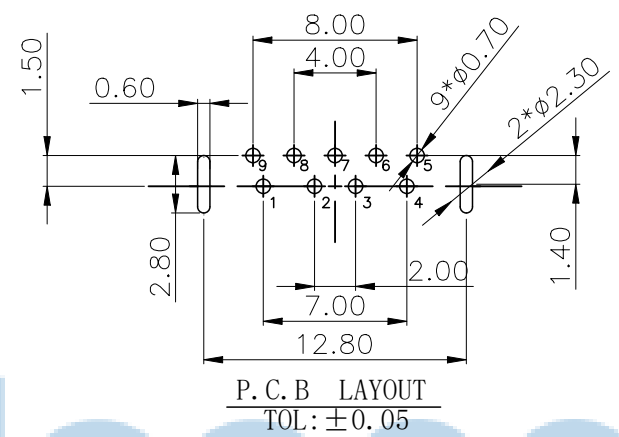

- NOTE:
- MATERIAL:
 - INSULATOR:LCP
 - CONTACT:COPPER ALLOY
 - SHELL:SUS201
 - ELECTRICAL CHARACTERISTICS;
 - CONTACT RESISTANCE:30mΩ MAXIMUM
 - CONTACT CURRENT RATING:1.5A
 - DIELECTRIC WITHSTANDING VOLTAGE:100 V R.M.S.
 - INSULATION RESISTANCE 100 MEGOHMS MIN
 - OPERATING TEMPERATURE:-20° C ~ 60° C
 - PLATING
 - TERMINAL:
 - 50u" MIN NICKEL ALL OVER
 - 100u"MIN Tin ON SOLDER AREA
 - (1~30)u"Au ON CONTACT AREA
 - SHELL:50u"MIN. NICKEL ALL OVER

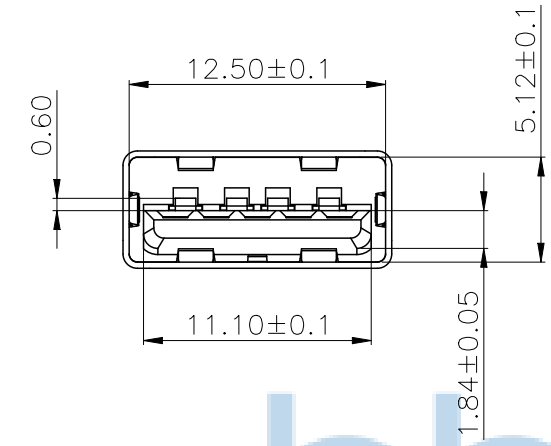
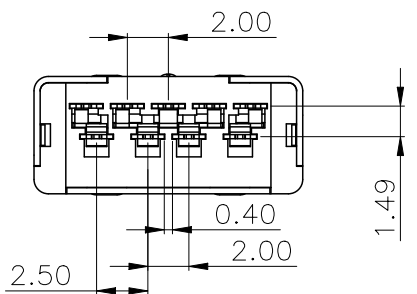
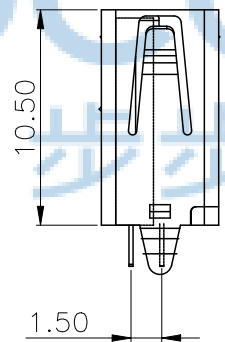
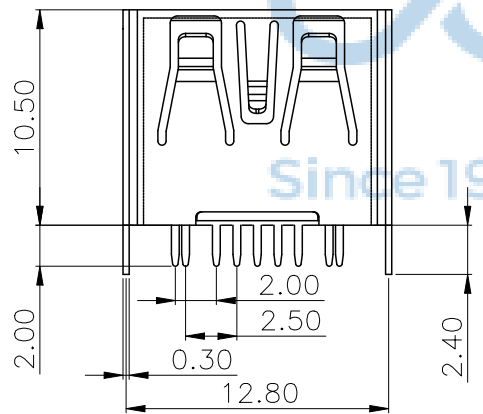

Pin NUMBER	SIGNAL NAME
1	VBUS
2	D-
3	D+
4	GND
5	StdA_SSRX-
6	StdA_SSRX+
7	GND_DRAIN
8	StdA_SSTX-
9	StdA_SSTX+
Shell	Shield



THIS DOCUMENT IS THE SOLE PROPERTY OF BBJconn Technology Co.,Ltd. Corporation AND SHOULD NOT BE USED IN WHOLE PRIOR WRITTEN PERMISSION.

PDWG NO: 0471-1

深圳市步步精科技有限公司

NAME: USB 3.0 AF 180度 H=10.50 两脚直插 端子
DIP 平口 LCP黑胶 不锈钢外壳 编带

APPD: JM_Zheng
CHKD: LYX
DR: SGF

PJ NO: 127-275-090001-Y4G
SIZE:A4 | DRW NO:
FINISH:SEE NOTES | MAT'L:SEE NOTES
SCALE:N/A | REV:A0 | UNIT:mm | PAGE:1/1

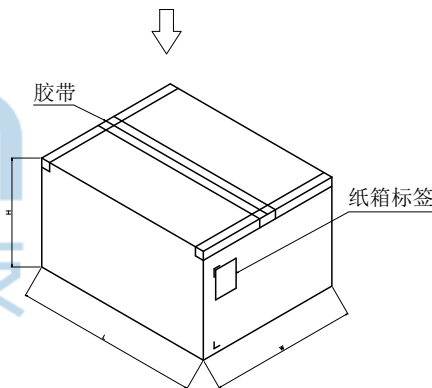
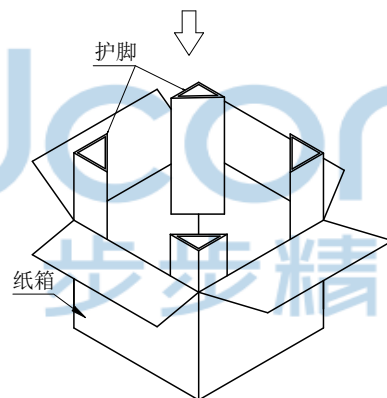
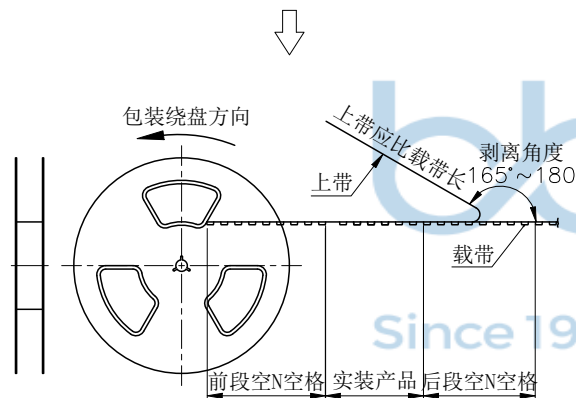
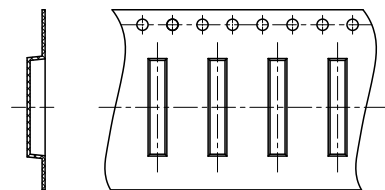

纸箱规格: W345*L345*H230MM

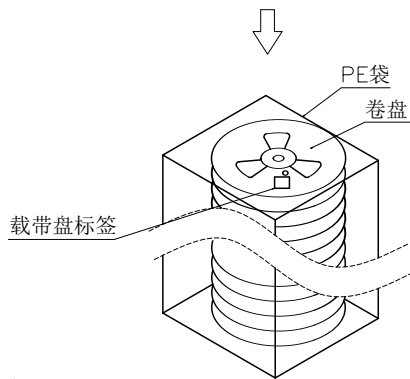

备注:

- 1、包装数量: 350/PCS/卷, 10卷/箱。
- 2、包装袋长度: 每卷前后各空10-20个空格, 中间包装。
- 3、材质:
载体: 聚丙烯 (PS), 阻抗 $10^{6-9} \Omega$
上带: 聚乙烯 (PET), 阻抗 $10^{6-11} \Omega$
卷盘: 聚苯乙烯。

THIS DOCUMENT IS THE SOLE PROPERTY OF BBJconn Technology Co.,Ltd. Corporation AND SHOULD NOT BE USED IN WHOLE OR IN PART WITHOUT PRIOR WRITTEN PERMISSION. PDWG,NO: 0471-1	深圳市步步精科技有限公司		NAME: USB 3.0 AF 180度 H=10.50 两脚直插 端子 DIP 平口 LCP黑胶 不锈钢外壳 编带	
	.X: ±0.38 .XX: ±0.25 .XXX: ±0.13	X': ±3' .X': ±2' .XX': ±1'	PJ. NO.: 127-275-090001-Y4G SIZE: A4 DRW NO.: FINISH: SEE NOTES MAT'L.: SEE NOTES SCALE: N/A REV.: A0 UNIT: mm PAGE: 2/2	
	APPD. JM_Zheng	CHKD. LYX		
	DR. SGF			