



REV.	DESCRIPTION	NAME	DATE
A	NEWS ISSUE		

NOTE:

1. MATERIAL:

- 1.1 INSULATOR:PBT & PA9T & LCP
- 1.2 CONTACT:COPPER ALLOY
- 1.3 SHELL:BRASS&SPCC&SUS201

2. ELECTRICAL CHARACTERISTICS;

- 2.1 CONTACTRESISTANCE:40mΩ MAXIMUM
- 2.2 CONTACT CURRENT RATING:1.5A
- 2.3 DIELECTRIC WITHSTANDING VOLTAGE:100 V R. M. S.
- 2.4 INSULATION RESISTANCE 100 MEGOHMS MIN
- 2.5 OPERATING TEMPEROTURE:-20° C ~ 60° C

3. PLATING

3.1 TERMINAL:

- 50u" MIN NICKEL ALL OVER
- 100u"MIN Tin ON SOLDER AREA
- (1~30)u"Au ON CONTACT AREA

3.2 SHELL:80u"MIN. NICEL ALL OVER

4. PART NO. :

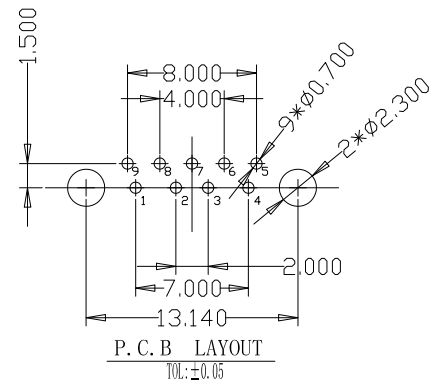
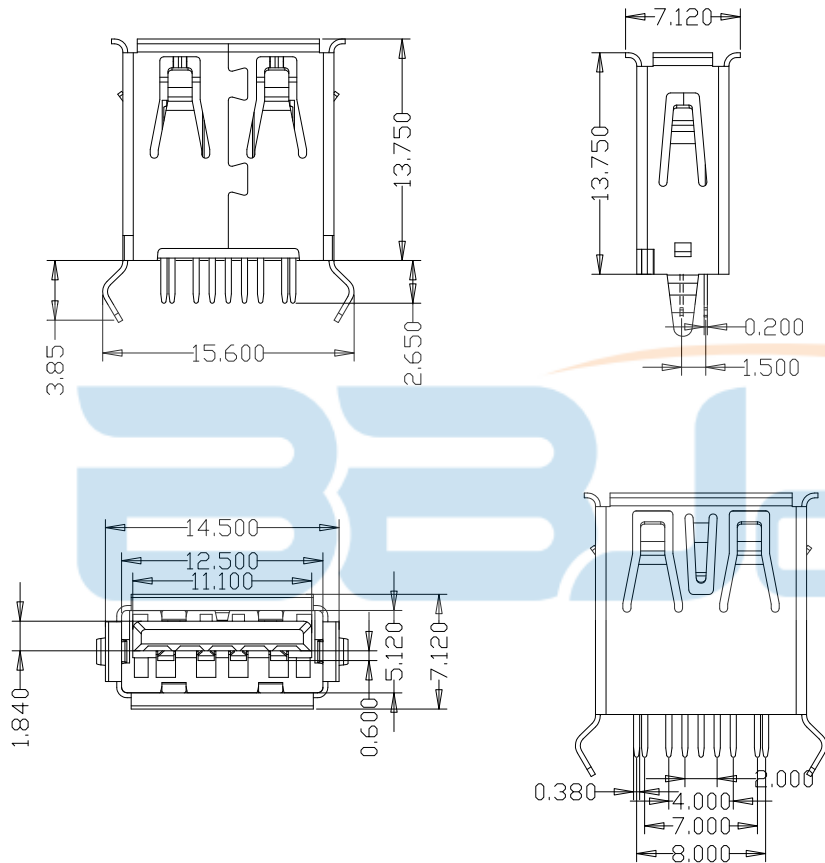

X. ±0.30		深圳市步步精科技有限公司 TITLE: USB3.0 AF180度 弯脚 H13.75 LCP蓝胶 不锈钢外壳 卷边 DIP				
X.X ±0.20						
X.XX ±0.15						
X.XXX ±0.05						
ANGEL ±1°						
DRAWN/ DATE	设计 LYX	SIZE:A4	UNIT:MM.	PART. NO:	UB.03.11-33-W003	
CHECKED/ DATE	审核 HMY	SCALE: 1:1		PROJECTION		REV.: 版本
APPROVED/ DATE	核准 LJP	DWG. PATH	0471-1		SHEET: 页码	

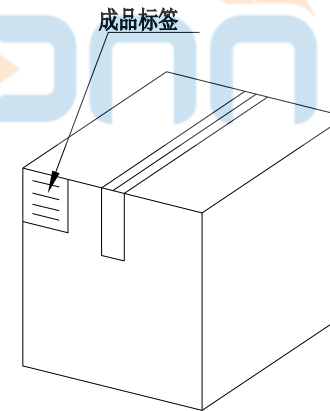
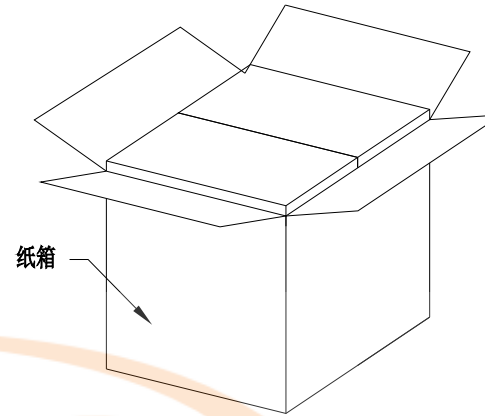
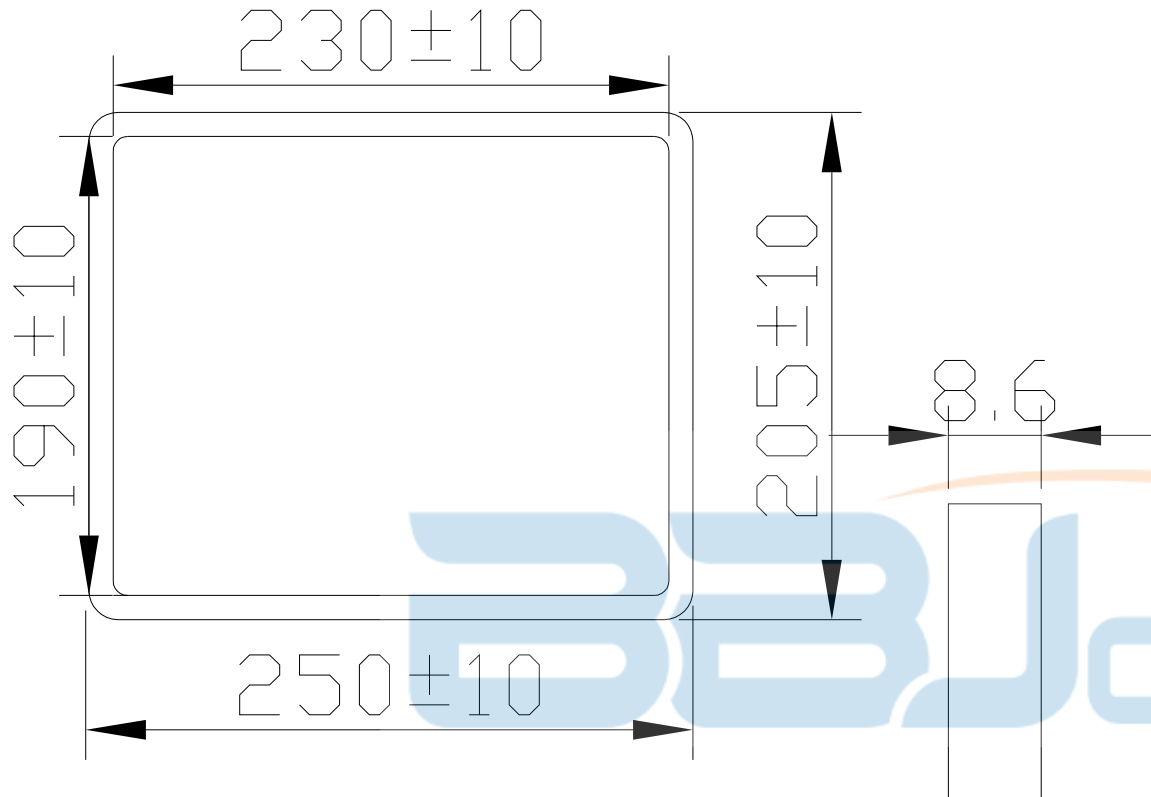

纸箱规格：350*210*290

1. 包装要求:

- 1.1 每盒吸塑盒包装100pcs;
- 1.2 每20盘放一箱，共计2000PCS;
- 1.3 纸箱外贴上标签



TOLERANCE UNSPECIFIED		深圳市步步精科技有限公司 TITLE: USB3.0 AF180度 弯脚 H13.75 LCP蓝胶 不锈钢外壳 卷边 DIP			
.0	±0.35	SIZE: A4	UNIT: MM.	PART. NO: UB.03.11-33-W003	
.00	±0.25	DRAWN/ DATE		设计	LYX
.000	±0.15	CHECKED/ DATE		审核	HMY
X. °	±2.00°	APPROVED/ DATE		核准	LJP
CUSTOMER DRAWING		DWG. PATH		0471-1	
		SCALE: 1:1		PROJECTION	REV.: 版本
				SHEET: 页码	