

REV.	ECN NO.	CONTENT	DATE	ENGINEER
A0		Initial release	/	TSP

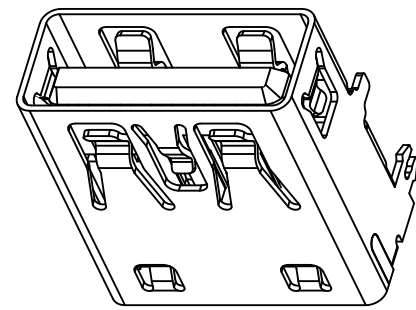

- NOTE:
- MATERIAL:
 - INSULATOR: HIGH TEMPERATURE PLASTIC UL 94 V-0;
 - CONTACT: COPPER ALLOY (T=0.20mm)
 - SHELL: SUS201/BRASS (T=0.30mm)
 - ELECTRICAL CHARACTERISTICS:
 - CONTACT RESISTANCE: 30mΩ Max
 - CONTACT CURRENT RATING: 1.5A
 - DIELECTRIC WITHSTANDING VOLTAGE: 500 V R. M. S.
 - INSULATION RESISTANCE 100 MEGOHMS Min
 - OPERATING TEMPERATURE: -40° C ~ 85° C
 - MECHANICAL CHARACTERISTICS:
 - MATING FORCE: 35 N Max
 - UNMATED FORCE: 10 N Min INITIAL; 8N Min AFTER TEST
 - DURABILITY: 5,000 CYCLES
 - PLATING
 - TERMINAL CONTACT: G/F GOLD PLATING ALL OVER 50u" MIN NICKEL AND 80u" MIN Tin ALL OVER 50u" MIN NICKEL ON SOLDER AREA
 - SHELL: 80u" MIN. NICKEL ALL OVER

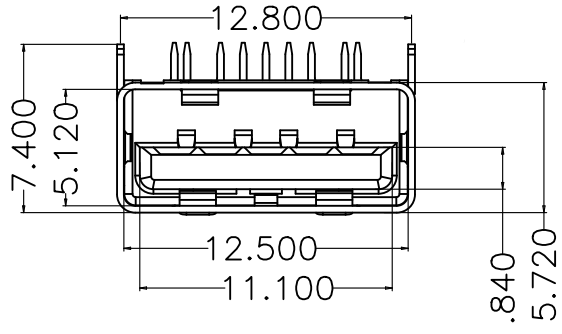
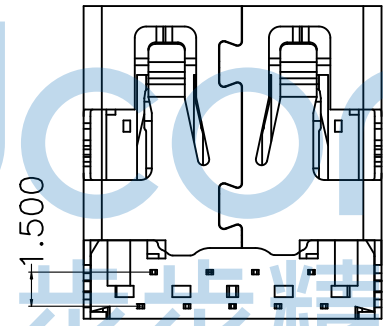
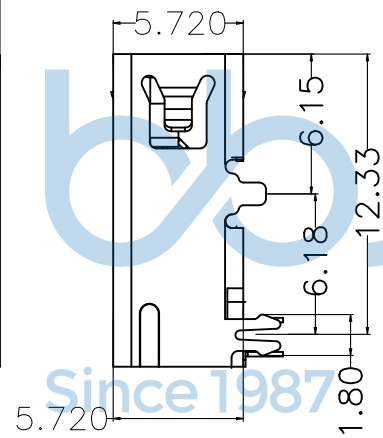
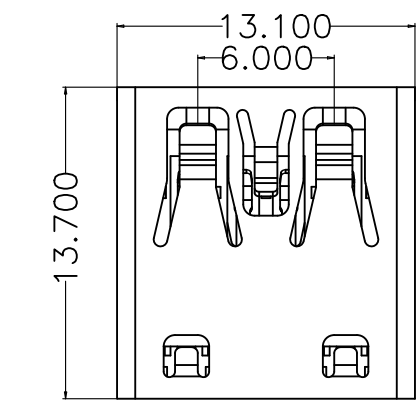

Pin #	SIGNAL NAME	DESCRIPTION	MATING SEQUENCE
1	VBUS	POWER	SECOND
2	D-	USB 2.0 DIFFERENTIAL PAIR	THIRD
3	D+		
4	GND	GROUND FOR POWER RETURN	SECOND
5	StdA_SSX-	SUPERSPEED RECEIVER DIFFERENTIAL PAIR	LAST
6	StdA_SSX+		
7	GND_DRAIN	GROUND FOR SIGNAL RETURN	FRIST
8	StdA_SSTX-	SUPERSPEED TRANSMITTER DIFFERENTIAL PAIR	
9	StdA_SSTX+		
Shell	Shield	CONNECTOR METAL SHELL	

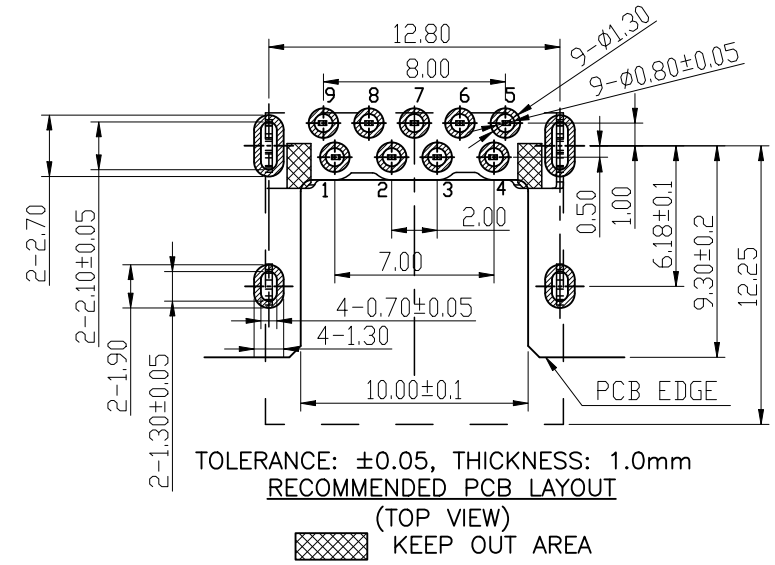

3	外壳	SUS//BRASS	NICKEL PLATED
2	端子	COPPER ALLOY	GOLD/TIN PLATED
1	胶芯	HIGH TEMPERATURE PLASTIC	UL94V-0
NO.	PART NAME	MATERIAL	DESCRIPTION

THIS DOCUMENT IS THE SOLE PROPERTY OF BBJconn Technology Co., Ltd. Corporation AND SHOULD NOT BE USED IN WHOLE OR IN PART WITHOUT PRIOR WRITTEN PERMISSION.

PDWG.NO: 0471-1 DR. TSP

深圳市步步精科技有限公司

NAME: USB 3.0 AF 90度 四脚插 端子DIP 镀金G-F L=13.70 平口 LCP蓝胶 不锈钢外壳

APPD. JM_Zheng P.J. NO.: UB.03.12-33-W002

CHKD. LYX SIZE: A4 DRW NO.:

FINISH: SEE NOTES MAT'L.: SEE NOTES

SCALE: N/A REV.: A0 UNIT: mm PAGE: 1/2

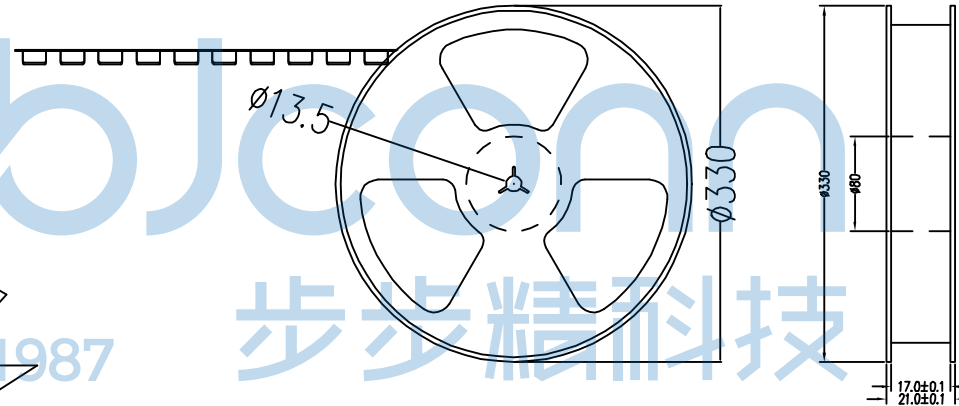
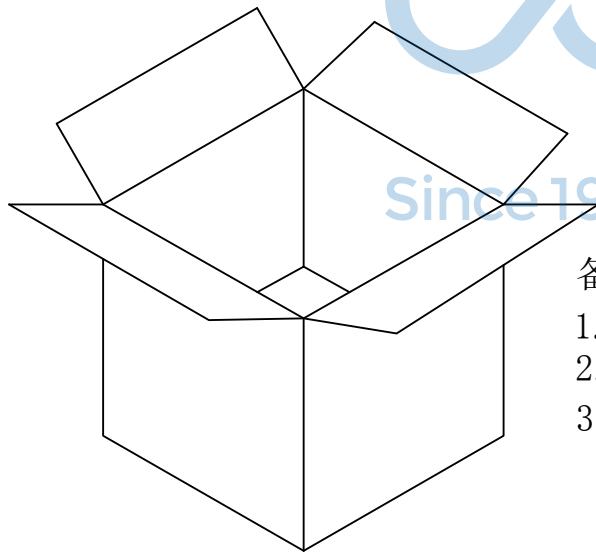
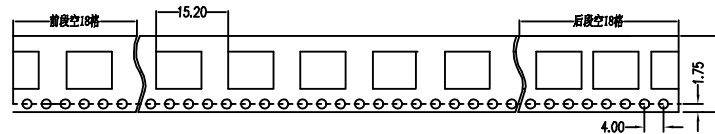
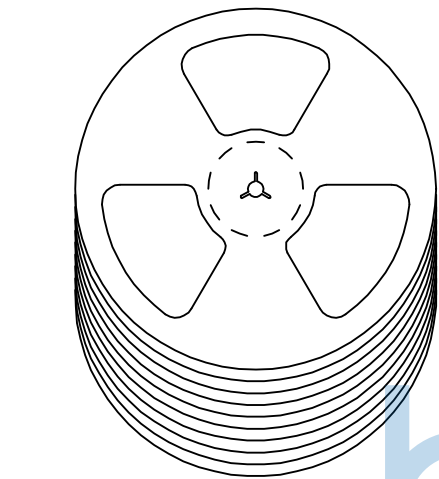

备注:

1. 包装数量: 400/PCS/卷, 10卷/箱。
2. 包装袋长度: 每卷前后各空10-20个空格, 中间包装。
3. 材质:
载体: 聚丙烯 (PS),
上带: 聚乙烯 (PET),
卷盘: 聚苯乙烯。

纸箱规格: 345*345*23MM

纸箱规格: 345*345*35MM

THIS DOCUMENT IS THE SOLE PROPERTY OF BBJconn Technology Co.,Ltd. Corporation AND SHOULD NOT BE USED IN WHOLE OR IN PART WITHOUT PRIOR WRITTEN PERMISSION.		深圳市步步精科技有限公司	
.X: ± 0.38 X': $\pm 3'$.XX: ± 0.25 .X': $\pm 2'$.XXX: ± 0.13 .XX': $\pm 1'$		NAME: USB 3.0 AF 90度 四脚插 端子DIP 镀金G-F L=13.70 平口 LCP蓝胶 不锈钢外壳	
APPD.	JM_Zheng		PJ. NO.: UB.03.12-33-W002
CHKD.	LYX		SIZE: A4 DRW NO.:
PDWG.NO:	0471-1	DR.	TSP
		FINISH: SEE NOTES	MAT'L.: SEE NOTES
		SCALE: N/A	REV.: A0 UNIT: mm PAGE: 2/2