

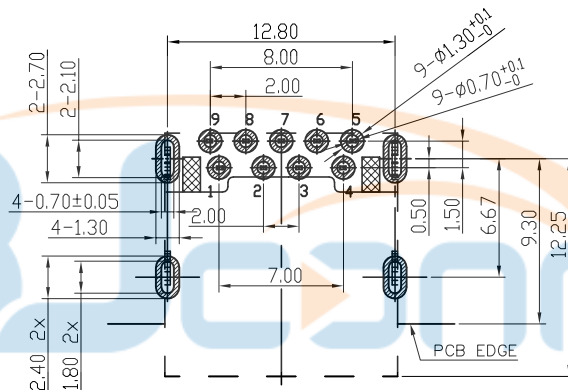

REV.	DESCRIPTION	NAME	DATE
A	NEWS ISSUE		

NOTE:
 1. MATERIAL:
 1.1 INSULATOR: HIGH TEMPERATURE PLASTIC PA9T UL 94 V-0; BLUE
 1.2 CONTACT: COPPER ALLOY (T=0.20mm)
 1.3 SHELL: SUS201 (T=0.30mm)
 2. ELECTRICAL CHARACTERISTICS:
 2.1 CONTACT RESISTANCE: 30mΩ Max
 2.2 CONTACT CURRENT RATING: 1.5A
 2.3 DIELECTRIC WITHSTANDING VOLTAGE: 500 V R.M.S.
 2.4 INSULATION RESISTANCE: 100 MEGOHMS Min
 2.5 OPERATING TEMPERATURE: -40° C ~ 85° C
 3 MECHANICAL CHARACTERISTICS:
 3.1 MATING FORCE: 35 N Max
 3.2 UNMATED FORCE: 10 N Min INITIAL; 8 N Min AFTER TEST
 3.3 DURABILITY: 5,000 CYCLES
 4. PLATING
 4.1 TERMINAL CONTACT: GOLD PLATING ALL OVER 50u" MIN NICKEL AND 80u" MIN Tin ALL OVER 50u" MIN NICKEL ON SOLDER AREA
 4.2 SHELL: 80u" MIN. NICEL ALL OVER

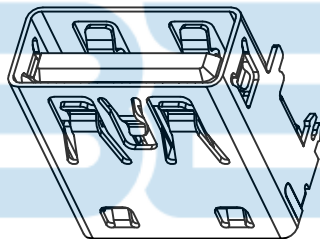
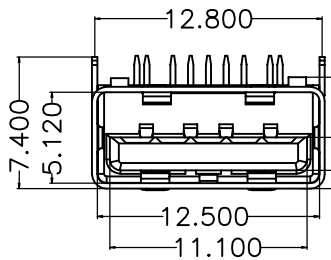
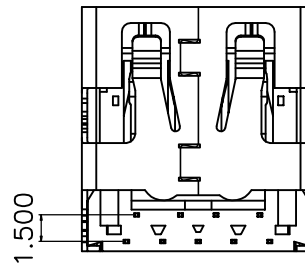
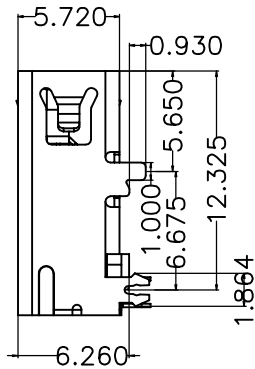
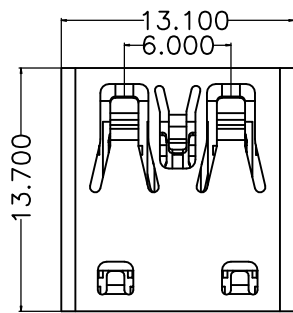

TOLERANCE: ±0.05, THICKNESS: 1.2mm
 RECOMMENDED PCB LAYOUT
 (TOP VIEW)
 [Cross-hatched area symbol] KEEP OUT AREA



NO.	PART NAME	MATERIAL	DESCRIPTION
3	外壳	BRASS	NICKEL PLATED
2	端子	COPPER ALLOY	GOLD/TIN PLATED
1	胶芯	HIGH TEMPERATURE PLASTIC	PA9T UL94V-0

Pin #	SIGNAL NAME	DESCRIPTION	MATING SEQUENCE
1	VBUS	POWER	SECOND
2	D-	USB 2.0 DIFFERENTIAL PAIR	THIRD
3	D+		
4	GND	GROUND FOR POWER RETURN	SECOND
5	StdA_SSRX-	SUPERSPEED RECEIVER DIFFERENTIAL PAIR	LAST
6	StdA_SSRX+		
7	GND_DRAIN	GROUND FOR SIGNAL RETURN	
8	StdA_SSTX-	SUPERSPEED TRANSMITTER DIFFERENTIAL PAIR	
9	StdA_SSTX+		
Shell	Shield	CONNECTOR METAL SHELL	FRIST

0 ±0.25
 0.0 ±0.20
 0.00 ±0.15

BBJconn 深圳市步步精科技有限公司

TITLE:
 USB 3.0 AF 90度 后两脚鱼叉 前两脚直插 L=13.7 H=6.26 PA9T蓝胶 平口 不锈钢外壳 DIP

DRAWN/ DATE	设计 LYX	SIZE:A4	UNIT:MM.	PART. NO: UB. 03. 12-33-W009
CHECKED/ DATE	审核 HMY	SCALE: 1:1	PROJECTION	REV.: 版本
APPROVED/ DATE	核准 LJP	DWG. PATH	0471-1	SHEET: 页码

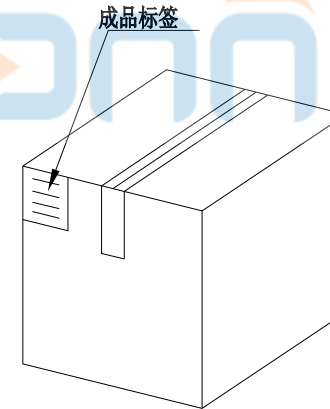
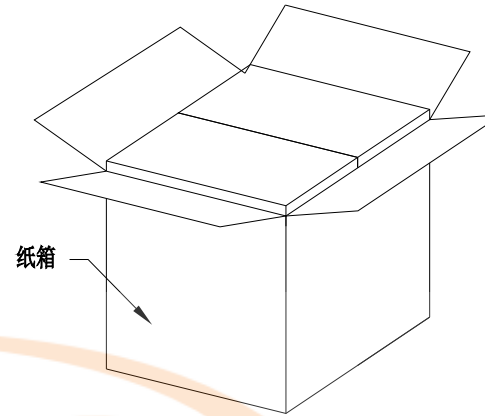
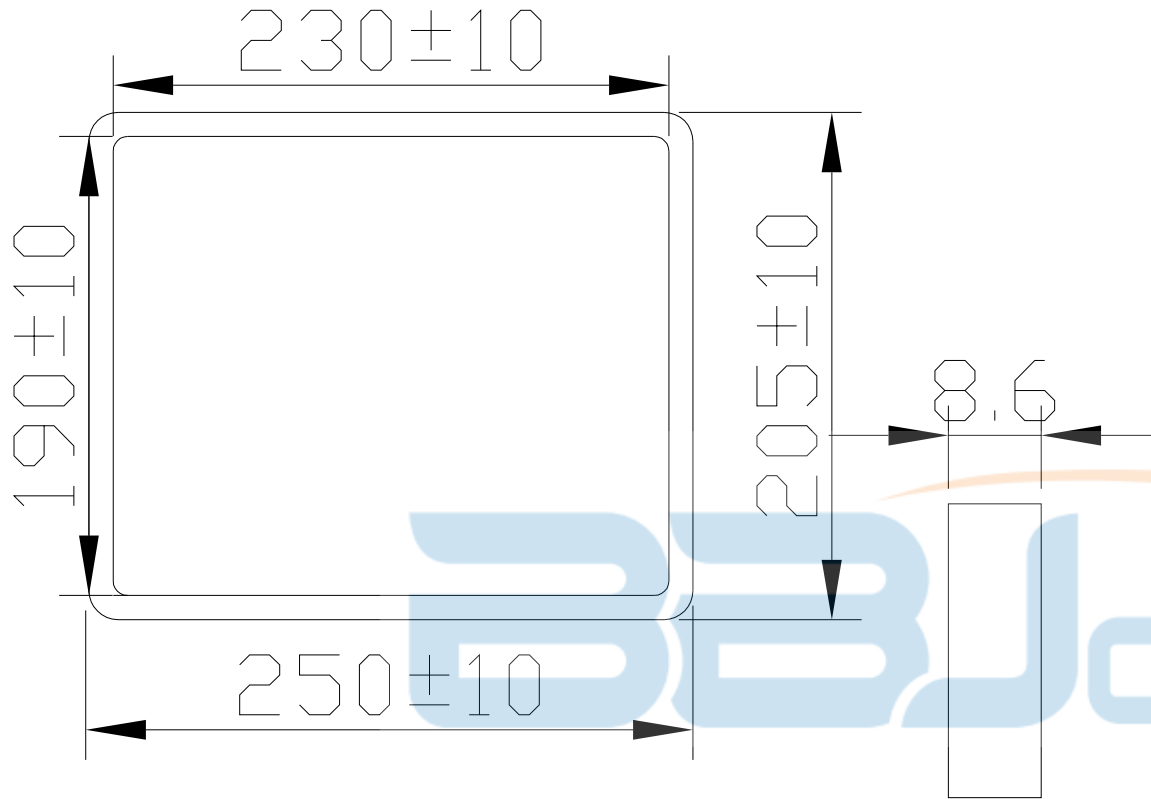

纸箱规格: 350*210*290

1. 包装要求:

- 1.1 每盒吸塑盒包装100pcs;
- 1.2 每20盘放一箱, 共计2000PCS;
- 1.3 纸箱外贴上标签



TOLERANCE UNSPECIFIED		深圳市步步精科技有限公司 TITLE: USB 3.0 AF 90度 后两脚鱼叉 前两脚直插 L=13.7 H=6.26 PA9T蓝胶 平口 不锈钢外壳 DIP								
.0	±0.35									
.00	±0.25	DRAWN/ DATE		设计	LYX	SIZE: A4	UNIT: MM.	PART. NO: UB.03.12-33-W009		
.000	±0.15	CHECKED/ DATE		审核	HMY	SCALE: 1:1		PROJECTION	REV.: 版本	
X.°	±2.00°	APPROVED/ DATE		核准	LJP	DWG. PATH	0471-1		SHEET: 页码	
CUSTOMER DRAWING										