

REV.	ECN NO	CONTENT	DATE	ENGINEER
A0		Initial release	/	TSP

NOTE:
 1. MATERIAL:
 1.1 INSULATOR:LCP+30%GF, UL94V-0,
 1.2 CONTACT 1~4PIN: C5191R/H,
 1.3 CONTACT 5~9PIN: C5191R/H,
 1.4 SHELL: SUS201 T=0.3
 2. PLATING:
 2.1 CONTACT: SELECTIVE GOLD PLATED ON CONTACT AREA
 100u" Min. MATTE TIN PLATED ON SOLDER TAIL
 50u" Min. NICKEL UNDER-PLATED
 2.2 SHELL:50u" Min. NICKEL PLATED OVERALL
 3. CHARACTERISTICS:
 3.1 ELECTRICAL CHARACTERISTICS:
 CONTACT RESISTANCE:30mΩ MAXIMUM
 CONTACT CURRENT RATING:1.5A
 DIELECTRIC WITHSTANDING VOLTAGE:500 V R. M. S.
 INSULATION RESISTANCE 1000 MEGOHMS MIN
 OPERATING TEMPERATURE:-25° C ~ +85° C
 3.2 MECHANICAL:
 MATING FORCE: 3.57Kg. Max.
 UNMATING FORCE: 1.02Kg. Min.
 4. DESIGN STANDARD ACCORDING TO USB_3.0 SPECIFICATION.

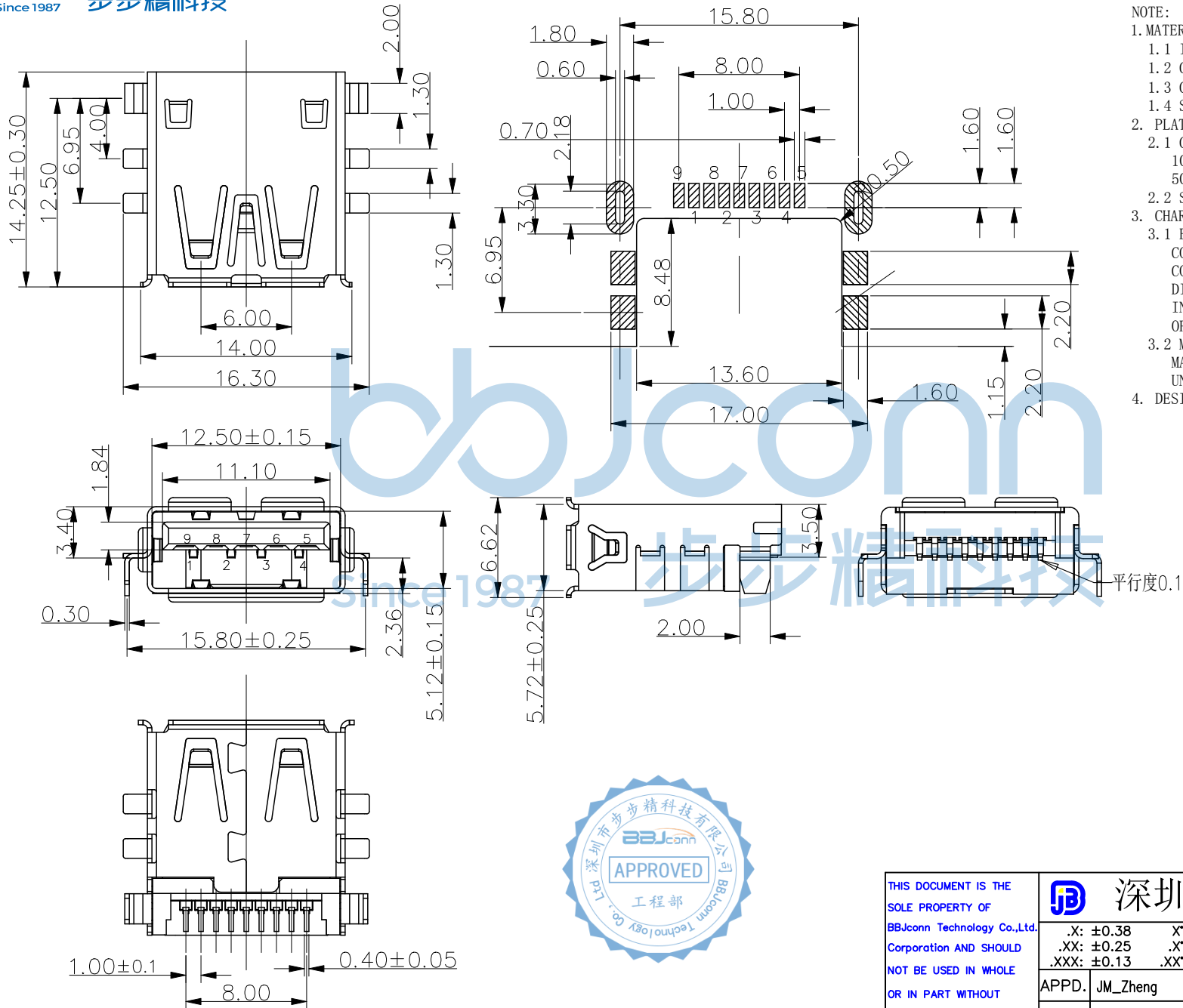

平行度0.1

THIS DOCUMENT IS THE SOLE PROPERTY OF BBJconn Technology Co.,Ltd. Corporation AND SHOULD NOT BE USED IN WHOLE OR IN PART WITHOUT PRIOR WRITTEN PERMISSION.		深圳市步步精科技有限公司 .X: ±0.38 .XX: ±0.25 .XXX: ±0.13 X': ±3' .X': ±2' .XX': ±1'		NAME: USB 3.0 AF 外壳脚前四脚贴片后两脚插 端子SMT 沉板2.22 L=14.25 卷边 LCP蓝胶 不锈钢外壳 APPD. JM_Zheng CHKD. LYX DR. TSP	
PDWG:NO: 0471-1		PJ. NO.: 127-271-090009-Y4G SIZE: A4 DRW NO.: FINISH: SEE NOTES MAT'L.: SEE NOTES		SCALE: N/A REV.: A0 UNIT: mm PAGE: 1/2	

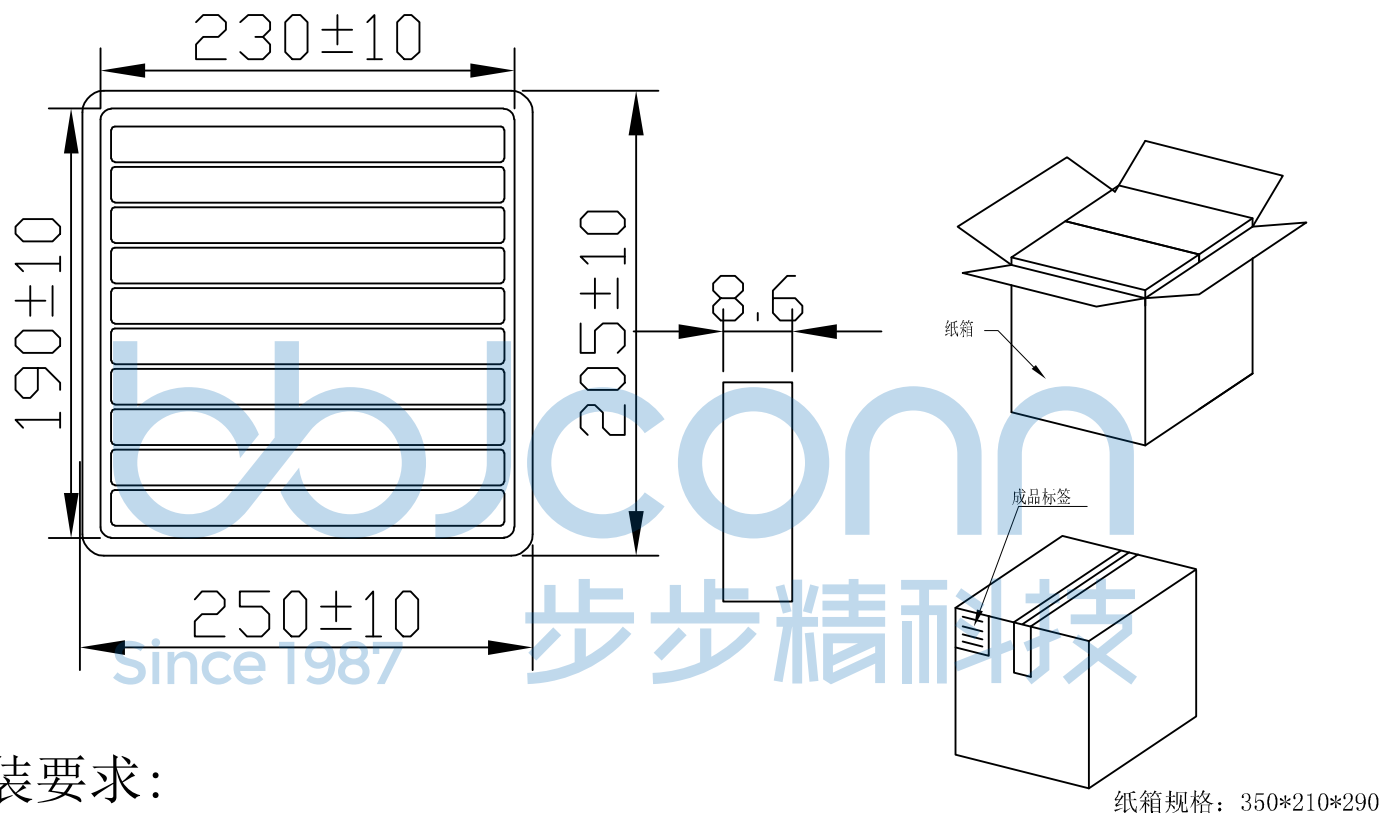

1. 包装要求:
- 1.1 每盒吸塑盒包装100pcs;
 - 1.2 每20盘放一箱, 共计2000PCS;
 - 1.3 纸箱外贴上标签。

纸箱规格: 350*210*290

THIS DOCUMENT IS THE SOLE PROPERTY OF BBJconn Technology Co.,Ltd. Corporation AND SHOULD NOT BE USED IN WHOLE OR IN PART WITHOUT PRIOR WRITTEN PERMISSION.		 深圳市步步精科技有限公司	
PDWG.NO: 0471-1		.X: ±0.38 .XX: ±0.25 .XXX: ±0.13	X*: ±3" .X*: ±2" .XX*: ±1"
APPD.	JM_Zheng	NAME: USB 3.0 AF 外壳脚前四脚贴片后两脚插 端子SMT 沉板2.22 L=14.25 卷边 LCP蓝胶 不锈钢外壳	
CHKD.	LYX	PJ. NO.: 127-271-090009-Y4G	
DR.	TSP	SIZE: A4 DRW NO.:	
		FINISH: SEE NOTES MAT'L.: SEE NOTES	
		SCALE: N/A REV.: A0 UNIT: mm PAGE: 2/2	