

REV.	ECN NO.	CONTENT	DATE	ENGINEER
A0				

NOTE:
 1. MATERIAL:
 1.1 INSULATOR:HIGH TEMPERATURE PLASTIC
 1.2 CONTACT:BRONZE
 1.3 SHELL:BRASS/SPCC/SUS304
 2. ELECTRICAL CHARACTERISTICS:
 2.1 CONTACTRESISTANCE:30mΩ MAX
 2.2 CONTACT CURRENT RATING:1.5A
 2.3 DIELECTRIC WITHSTANDING VOLTAGE:100 V R.M.S.
 2.4 INSULATION RESISTANCE 100 MΩ MIN
 2.5 OPERATING TEMPERATURE:-40° C ~ 85° C
 3. MECHANICAL CHARACTERISTICS:
 3.1 MATING FORCE:3.57kgf MAX
 3.2 UNMATING FORCE:1.02kgf MIN
 3.3 DURABILITY:MANDATORY:1,500 CYCLES
 4. PLATING
 4.1 TERMINAL:
 50u" MIN NICKEL ALL OVER
 100u"MIN Tin ON SOLDER AREA
 (1~30)u"Au ON CONTACT AREA
 4.2 SHELL:50u"MIN. NICEL ALL OVER

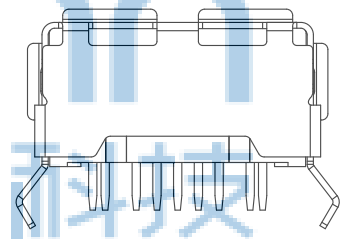

	DIMA
A	2.10
B	2.30

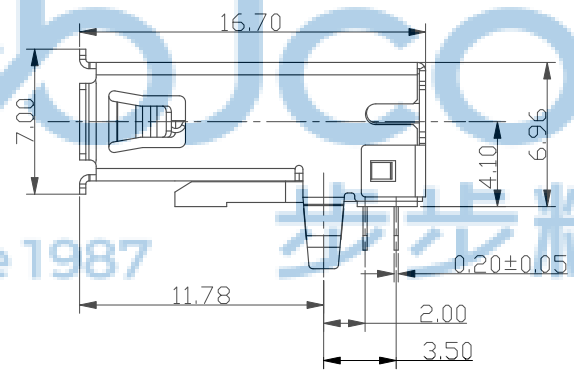
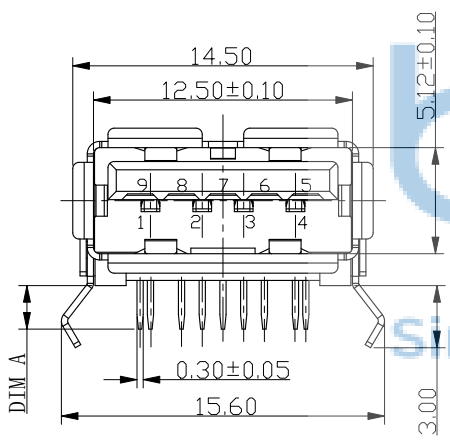
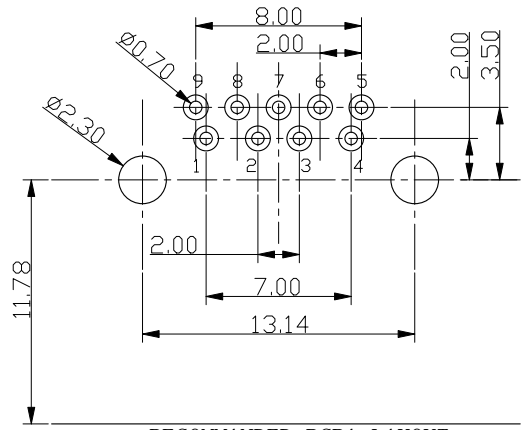
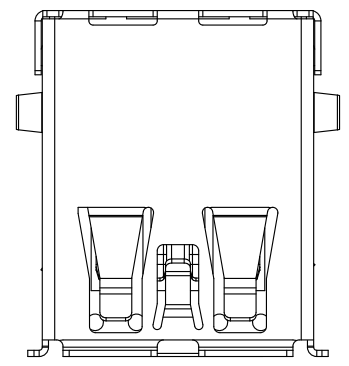
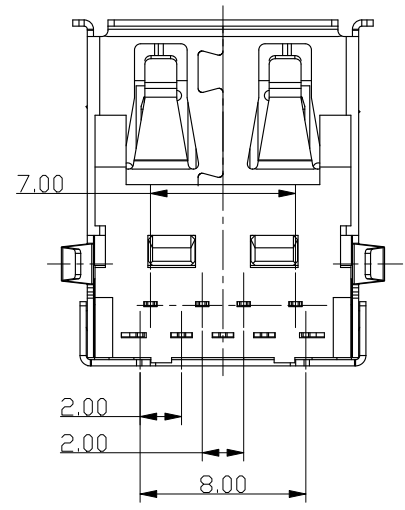

Pin NUMBER	SIGNAL NAME
1	VBUS
2	D-
3	D+
4	GND
5	StdA_SSRX-
6	StdA_SSRX+
7	GND_DRAIN
8	StdA_SSTX-
9	StdA_SSTX+
Shell Shield	

THIS DOCUMENT IS THE SOLE PROPERTY OF BBJconn Technology Co.,Ltd. Corporation AND SHOULD NOT BE USED IN WHOLE OR IN PART WITHOUT PRIOR WRITTEN PERMISSION.

PDWG:NO: 0471-1

APPD. JM_Zheng
CHKD. TSP
DR. LYX

NAME: USB 3.0 AF 90度 L=16.70 H=6.96 后两脚插 弯脚 端子DIP 端子脚长2.30 卷边 LCP蓝胶 铜壳

PJ. NO.: 127-272-090021-Y4G
SIZE: A4 DRW NO. :
FINISH: SEE NOTES MAT' L. : SEE NOTES
SCALE: N/A REV.: A0 UNIT: mm PAGE: 1/1

深圳市步步精科技有限公司

REV.	ECN NO.	CONTENT	DATE	ENGINEER
A0				

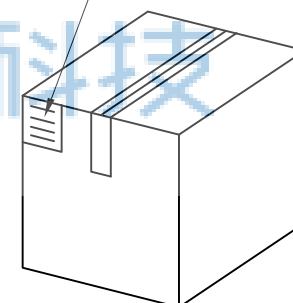
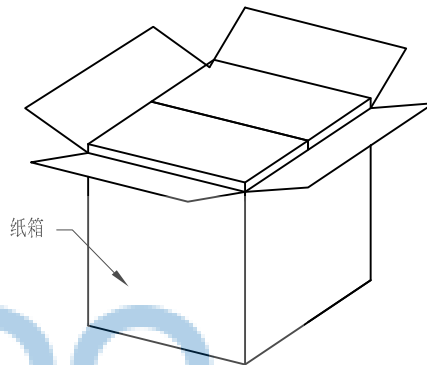
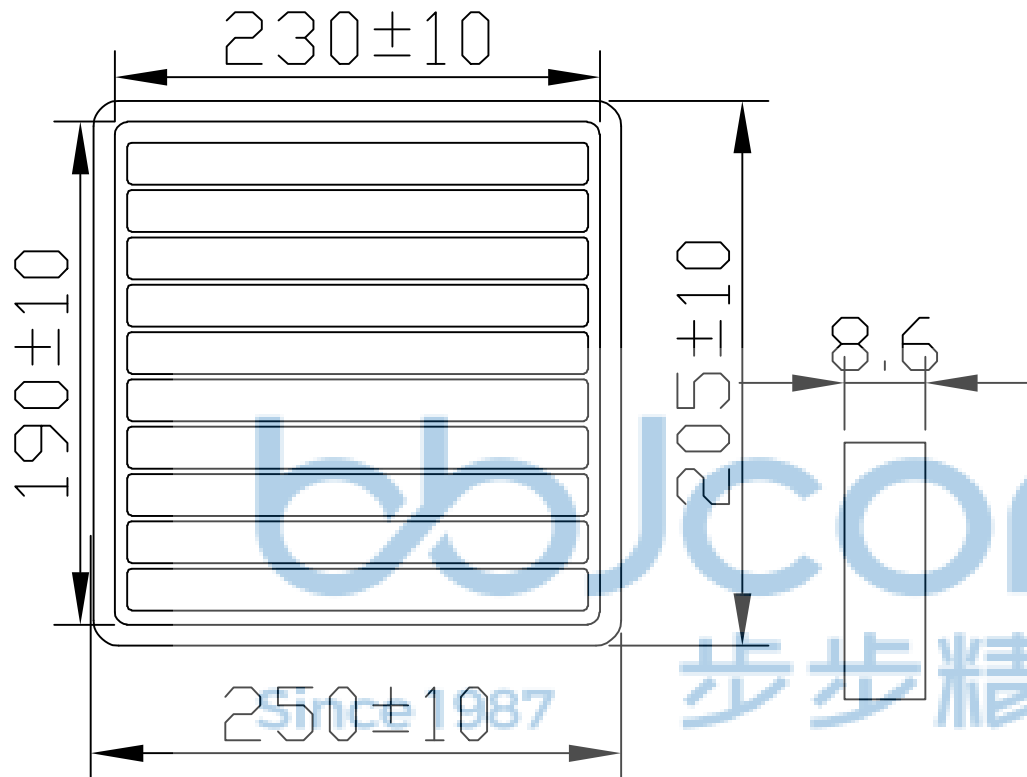

纸箱规格: 350*210*290

1. 包装要求:
- 1.1 每盒吸塑盒包装100PCS;
 - 1.2 每20盘放一箱, 共计2000PCS;
 - 1.3 纸箱外贴上标签

THIS DOCUMENT IS THE SOLE PROPERTY OF BBJconn Technology Co.,Ltd Corporation AND SHOULD NOT BE USED IN WHOLE OR IN PART WITHOUT PRIOR WRITTEN PERMISSION. PDWG.NO: 0471-1	深圳市步步精科技有限公司		NAME: USB 3.0 AF 90度 L=16.70 H=6.96 后两脚插 弯脚 端子DIP 端子脚长2.30 卷边 LCP蓝胶 铜壳		
	.X: ±0.38 .XX: ±0.25 .XXX: ±0.13	X': ±3" .X': ±2" .XX': ±1"	APPD. JM_Zheng	PJ. NO.: 127-272-090021-Y4G	SIZE: A4 DRW NO.:
	CHKD. LYX	DR. TSP	FINISH: SEE NOTES	MAT'L.: SEE NOTES	SCALE: N/A
	REV.: A0	UNIT: mm	PAGE: 1/1		