

REV.	DESCRIPTION	NAME	DATE
A	NEWS ISSUE		

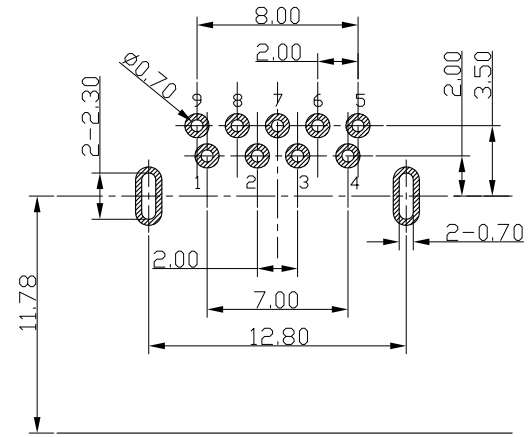

RECOMMENDED PCBA LAYOUT
(TOLERANCE+/-0.05)

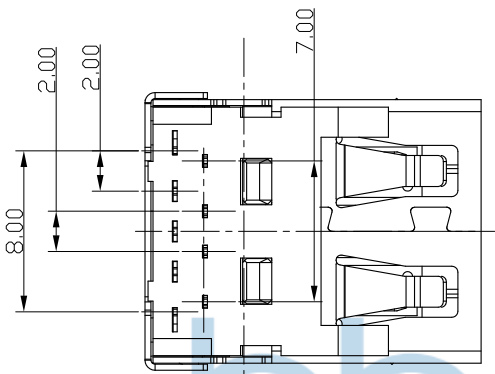
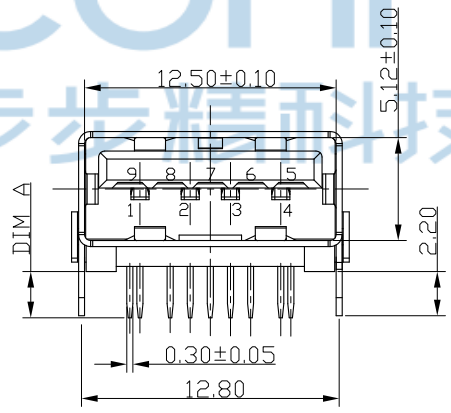
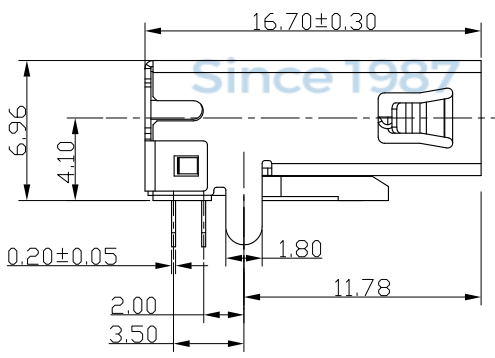

NOTE:
 1. MATERIAL:
 1.1 INSULATOR:HIGH TEMPERATURE PLASTIC LCP
 1.2 CONTACT:BRONZE C5191
 1.3 SHELL:SUS201
 2. ELECTRICAL CHARACTERISTICS:
 2.1 CONTACTRESISTANCE:30mΩ MAX
 2.2 CONTACT CURRENT RATING:1.5A
 2.3 DIELECTRIC WITHSTANDING VOLTAGE:100 V R. M. S.
 2.4 INSULATION RESISTANCE 100 MΩ MIN
 2.5 OPERATING TEMPERATURE:-20° C ~ 60° C
 3 MECHANICAL CHARACTERISTICS:
 3.1 MATING FORCE:3.57kgf MAX
 3.2 UNMATING FORCE:1.02kgf MIN
 3.3 DURABILITY:MANDATORY:1,500 CYCLES
 4. PLATING
 4.1 TERMINAL:
 50u" MIN NICKEL ALL OVER
 80u"MIN Tin ON SOLDER AREA
 (1~30)u"Au ON CONTACT AREA
 4.2 SHELL:80u"MIN. NICEL ALL OVER

DIMA
2.10
2.30

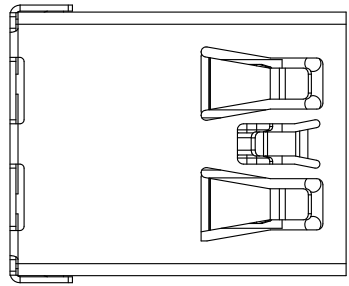

Pin NUMBER	SIGNAL NAME
1	VBUS
2	D-
3	D+
4	GND
5	StdA_SSRX-
6	StdA_SSRX+
7	GND_DRAIN
8	StdA_SSTX-
9	StdA_SSTX+
Shell	Shield

TOLERANCE UNSPECIFIED	
.0	±0.35
.00	±0.25
.000	±0.15
X.°	±2.00°
CUSTOMER DRAWING	

深圳市步步精科技有限公司

TITLE: USB 3.0 AF 90度 L=16.70 后两脚插 直脚 端子DIP 端子脚长2.30
端子镀金3u 带后盖 平口 LCP蓝胶 不锈钢外壳

DRAWN/ DATE	设计 TSP	SIZE:A4	UNIT:MM.	PART. NO:	127-272-090025-Y4G
CHECKED/ DATE	审核 LYX	SCALE: 1:1	PROJECTION	REV.:	版本
APPROVED/ DATE	核准 LJP	DWG. PATH		0471-1	SHEET: 页码



30 ± 10

190 ± 10

150 ± 10

8.6

250 ± 10

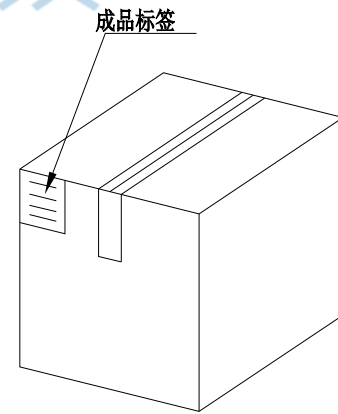
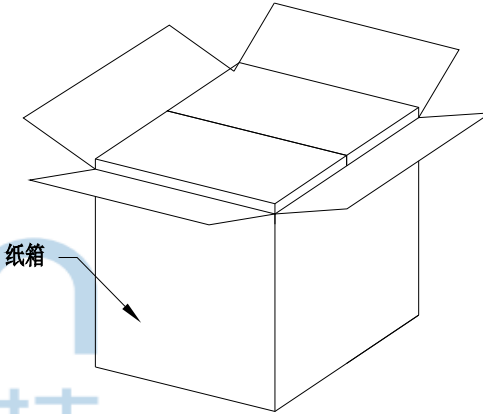

纸箱规格：350*210*290

1. 包装要求:

- 1.1 每盒吸塑盒包装100 pcs;
- 1.2 每20盘放一箱，共计2000PCS;
- 1.3 纸箱外贴上标签



TOLERANCE UNSPECIFIED		深圳市步步精科技有限公司 TITLE: USB 3.0 AF 90度 L=16.70 后两脚插 直脚 端子DIP 端子脚长2.30 端子镀金3u 带后盖 平口 LCP蓝胶 不锈钢外壳							
.0	±0.35								
.00	±0.25	DRAWN/ DATE		设计	TSP	SIZE: A4	UNIT: MM.	PART. NO: 127-272-090025-Y4G	
.000	±0.15	CHECKED/ DATE		审核	LYX	SCALE: 1:1		PROJECTION	REV.: 版本
X. °	±2.00°	APPROVED/ DATE		核准	LJP	DWG. PATH	0471-1		SHEET: 页码
CUSTOMER DRAWING									