

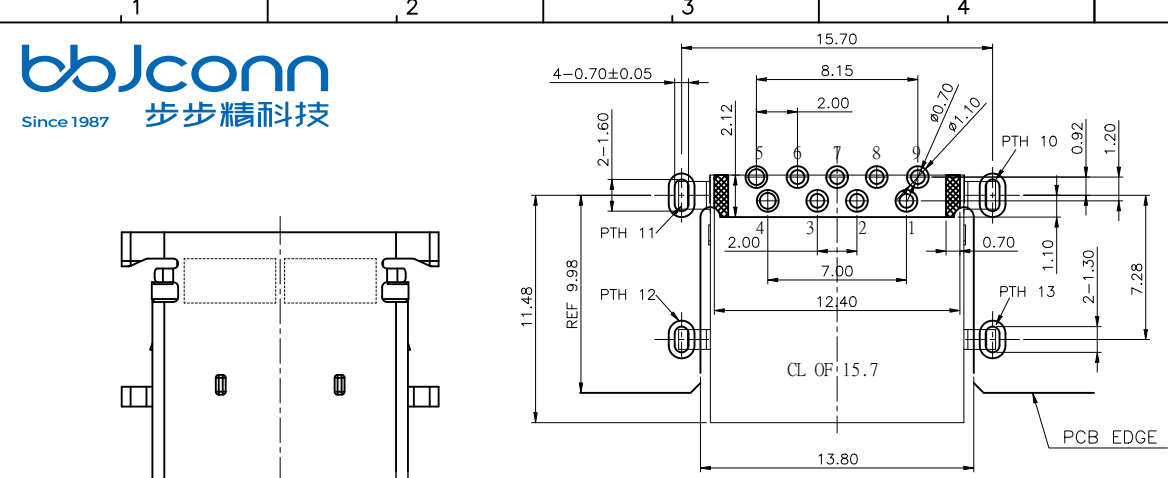

REV.	ECN NO	CONTENT	DATE	ENGINEER
A0		Initial release	/	TSP

- NOTE:
- MATERIAL:
 - INSULATOR: HIGH TEMPERATURE PLASTIC LCP UL 94 V-0;
 - CONTACT: COPPER ALLOY C5191 (T=0.2mm)
 - SHELL: SUS201 (T=0.30mm)
 - ELECTRICAL CHARACTERISTICS:
 - CONTACT RESISTANCE: 30m MAX.
 - CONTACT CURRENT RATING: 1.5A
 - DIELECTRIC WITHSTANDING VOLTAGE: 500 V R. M. S.
 - INSULATION RESISTANCE 100 MEGOHMS M
 - OPERATING TEMPERATURE: -55° C ~ 85° C
 - RATE VOLTAGE: 30V DC
 - MECHANICAL CHARACTERISTICS:
 - MATING FORCE: 10 N Min INITIAL; 8 N Min AFTER TEST
 - UNMATED FORCE: 35 N Max
 - DURABILITY: 5,000 CYCLES
 - PLATING
 - TERMINAL CONTACT: GOLD PLATING ALL OVER
50u" MIN NICKEL AND 80u" MIN Matte Tin
NICKEL IN SOLDER AREA
 - SHELL: 50u" MIN. NICKEL ALL OVER



TOLERANCE: ±0.05, THICKNESS: 1.0~1.2mm
RECOMMENDED PCB LAYOUT

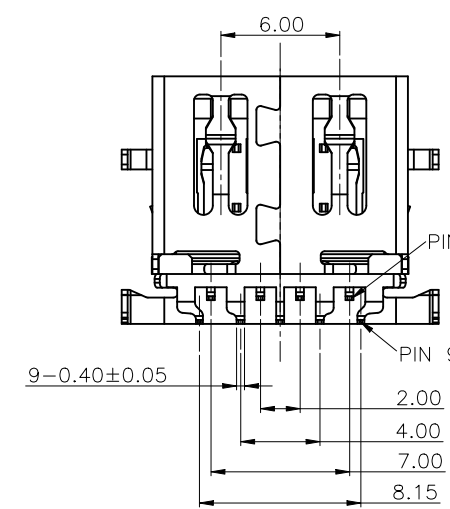
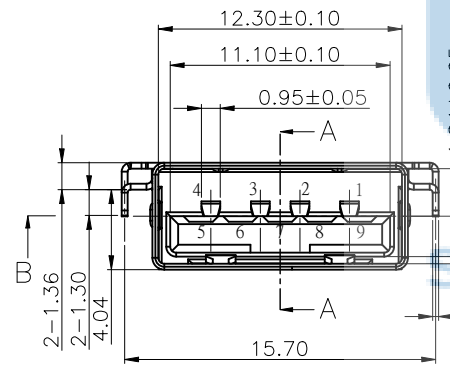

2.00	⊕ 0.10
4.00	⊕ 0.10
7.00	⊕ 0.10
8.15	⊕ 0.10

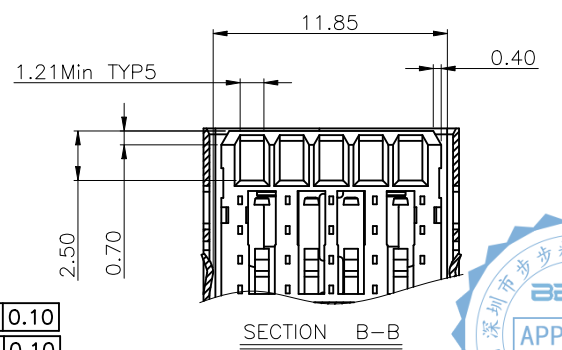
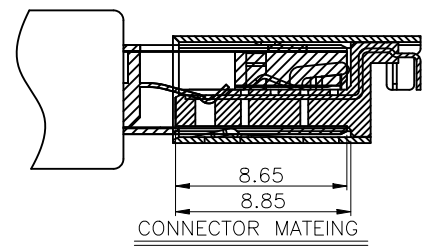
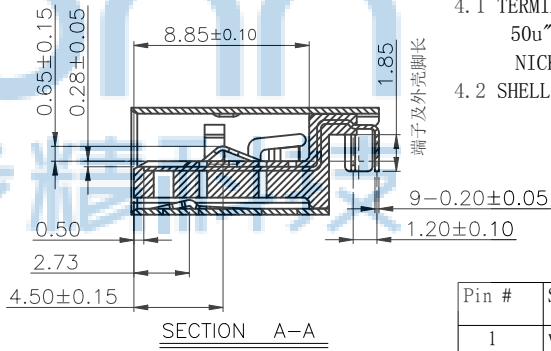
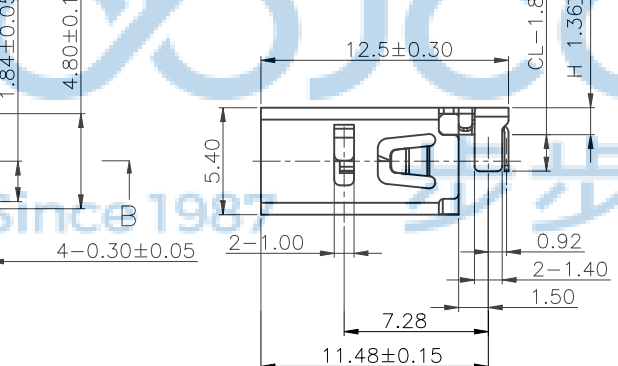

Pin #	SIGNAL NAME	DESCRIPTION	MATING SEQUENCE
1	VBUS	POWER	SECOND
2	D-	USB 2.0 DIFFERENTIAL PAIR	THIRD
3	D+		
4	GND	GROUND FOR POWER RETURN	SECOND
5	StdA_SSRX-	SUPERSPEED RECEIVER DIFFERENTIAL PAIR	LAST
6	StdA_SSRX+		
7	GND_DRAIN	GROUND FOR SIGNAL RETURN	
8	StdA_SSTX-	SUPERSPEED TRANSMITTER DIFFERENTIAL PAIR	
9	StdA_SSTX+		
Shell	Shield	CONNECTOR METAL SHELL	FRIST



THIS DOCUMENT IS THE SOLE PROPERTY OF BBJconn Technology Co., Ltd. Corporation AND SHOULD NOT BE USED IN WHOLE OR IN PART WITHOUT PRIOR WRITTEN PERMISSION. PDWG:NO: 0471-1

深圳市步步精科技有限公司

NAME: USB 3.0 AF 90度 反向 沉板 4.04 L=12.50 端子DIP 平口 LCP蓝胶 不锈钢外壳

PJ. NO.: 127-272-090026-Y4G
SIZE: A4 DRW NO.:
FINISH: SEE NOTES MAT'L.: SEE NOTES
SCALE: N/A REV.: A0 UNIT: mm PAGE: 1/2

APPD.	JM_Zheng
CHKD.	LYX
DR.	TSP



REV.	ECN NO	CONTENT	DATE	ENGINEER
A0		Initial release	/	TSP

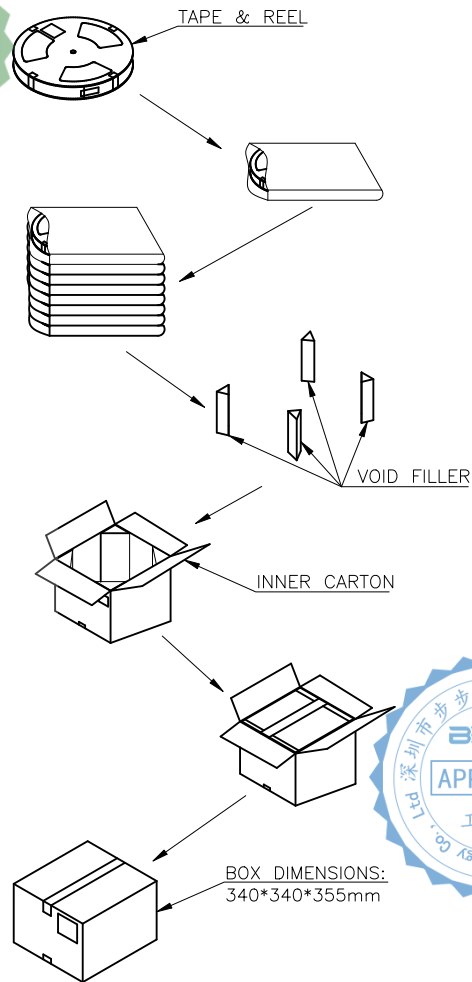
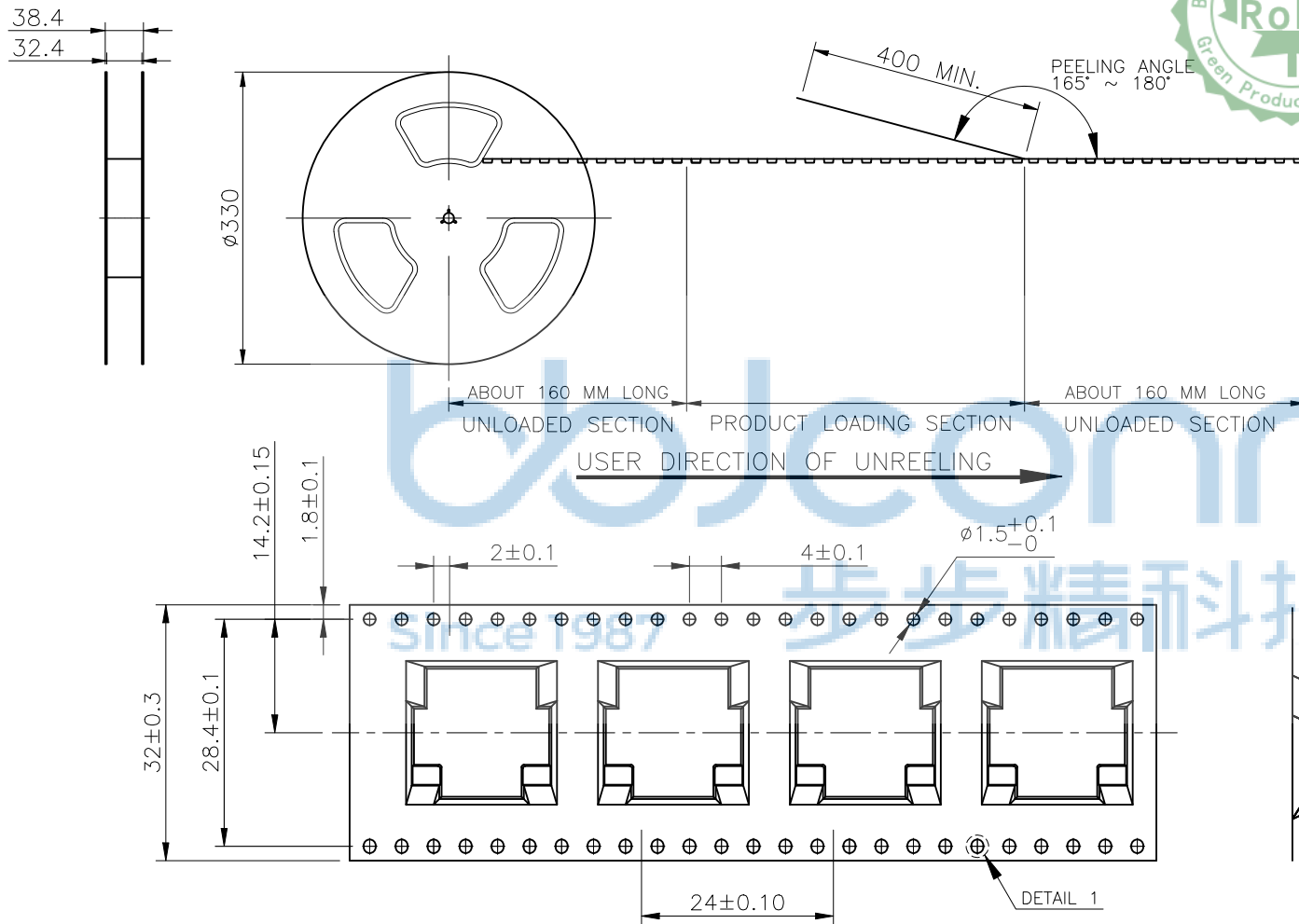

NOTE:

- MATERIAL:
BOX: FIBREBOARD, CORRUGATED, DOUBLE WALL
TAPE: POLYSTYRENES, HEAT-RESISTANT TEMPERATURE: 120° C, BLACK COLOR.
REEL: POLYSTYRENES, HEAT-RESISTANT TEMPERATURE: 70° C, BLUE COLOR.
BAG: POLYETHYLENE, HEAT-RESISTANT TEMPERATURE: 100° C.
- PEELING STRENGTH: 0.1 ~ 1.3 N (10 ~ 130 GRAMS)
- PEELING SPEED: 300 mm/min.
- EACH BAG SHALL BE INCLUDED DESICCANT.

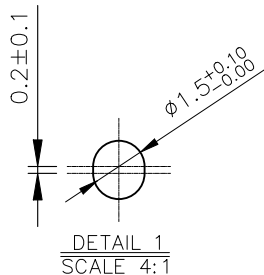

450	9	4050 PCS	-- KG	-- KG
PCS/ REEL	REELS/ CARTON	QUANTITY	GROSS WEIGHT	NET WEIGHT

THIS DOCUMENT IS THE SOLE PROPERTY OF BBJconn Technology Co.,Ltd. Corporation AND SHOULD NOT BE USED IN WHOLE OR IN PART WITHOUT PRIOR WRITTEN PERMISSION.		深圳市步步精科技有限公司 .X: ±0.38 .X': ±3' .XX: ±0.25 .X'': ±2' .XXX: ±0.13 .X''': ±1'		NAME: USB 3.0 AF 90度 反向 沉板4.04 L=12.50 端子DIP 平口 LCP蓝胶 不锈钢外壳 PJ. NO.: 127-272-090026-Y4G SIZE: A4 DRW NO.: FINISH: SEE NOTES MAT'L.: SEE NOTES SCALE: N/A REV.: A0 UNIT: mm PAGE: 2/2	
APPD.	JM_Zheng	CHKD.	LYX	DR.	TSP
PDWG.NO:	0471-1				