

REV.	ECN NO.	CONTENT	DATE	ENGINEER
A0				

- NOTE:
- MATERIAL:
 - INSULATOR: LCP UL 94V-0
 - CONTACT: BRONZE (T=0.20mm)
 - SHELL: SUS201 (T=0.30mm)
 - ELECTRICAL CHARACTERISTICS:
 - CONTACT RESISTANCE: 30mΩ MAXIMUM
 - CONTACT CURRENT RATING: 1.5A
 - DIELECTRIC WITHSTANDING VOLTAGE: 500 V R. M. S.
 - INSULATION RESISTANCE 1000 MEGOHMS MIN
 - OPERATING TEMPERATURE: -40° C ~ 85° C
 - MECHANICAL CHARACTERISTICS:
 - MATING FORCE: 3.57kg MAX
 - UNMATED FORCE: 1.02kg MIN
 - DURABILITY: MANDATORY: 5,000 CYCLES
 - PLATING
 - TERMINAL:
 - 50u" MIN NICKEL ALL OVER
 - 100u" MIN Tin ON SOLDER AREA
 - (1~30)u" Au ON CONTACT AREA
 - SHELL: 100u" MIN. NICKEL ALL OVER

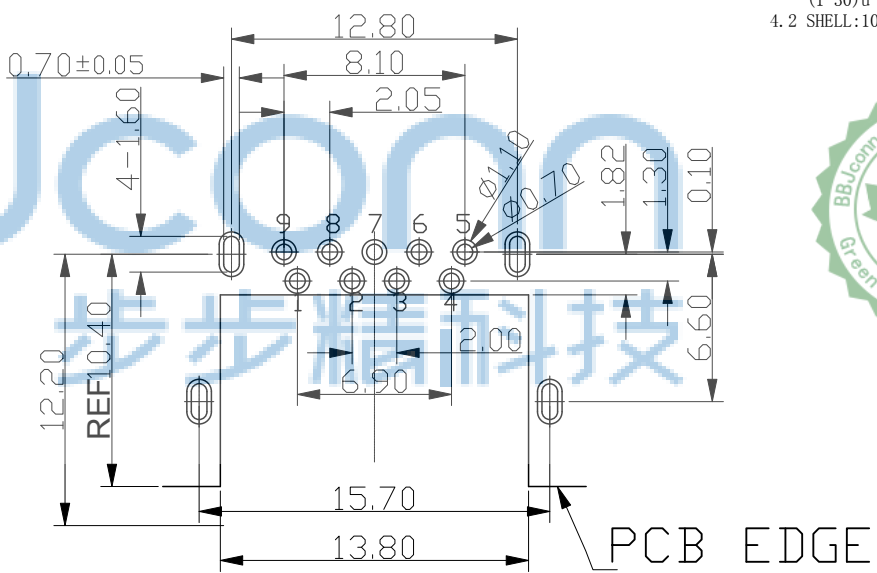
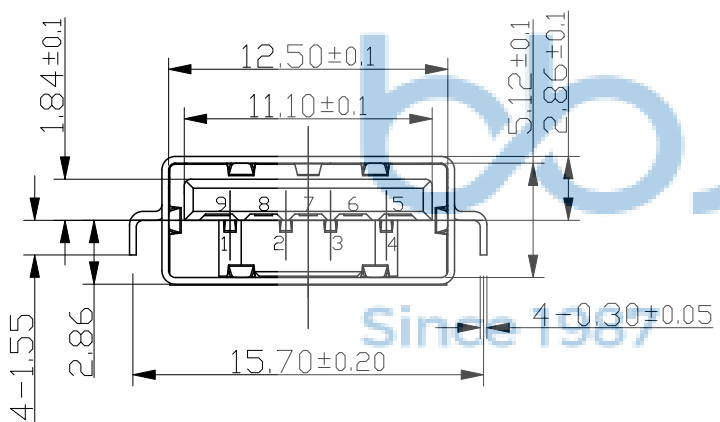
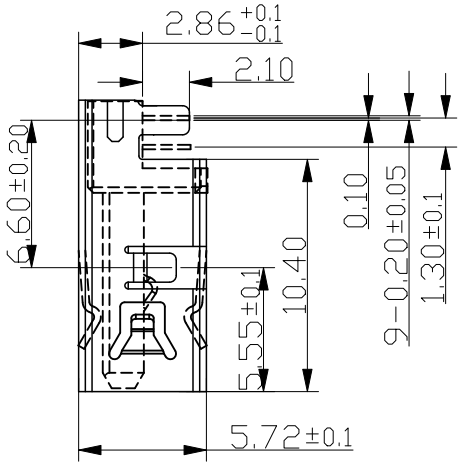
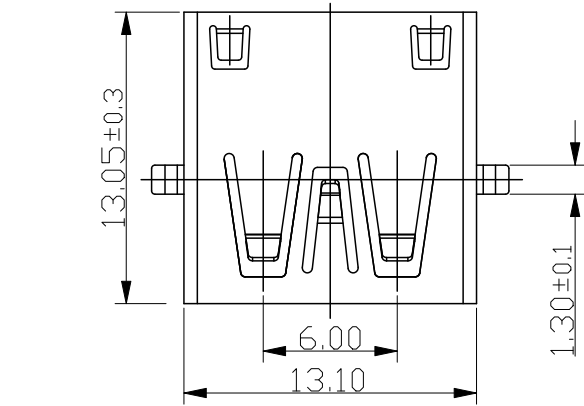

TOLERANCE: ±0.05, THICKNESS: 1.6 mm
RECOMMENDED PCB LAYOUT

Pin NUMBER	SIGNAL NAME
1	VBUS
2	D-
3	D+
4	GND
5	StdA_SSRX-
6	StdA_SSRX+
7	GND_DRAIN
8	StdA_SSTX-
9	StdA_SSTX+
Shell	Shield

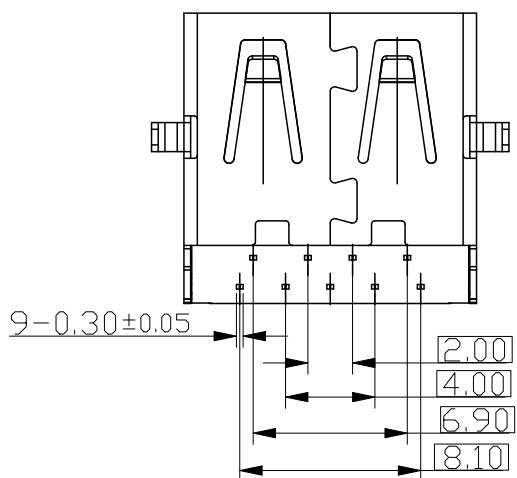

THIS DOCUMENT IS THE SOLE PROPERTY OF **深圳市步步精科技有限公司** (BBJconn Technology Co., Ltd.)

NAME: USB 3.0 AF 四脚插 L=13.05 沉板2.86 端子DIP 端子镀金1u 平口 LCP蓝胶 不锈钢外壳 编带

APPD. JM_Zheng

CHKD. LYX

DR. TSP

PJ. NO.: 127-272-090032-Y4G

SIZE: A4 DRW NO.:

FINISH: SEE NOTES MAT'L.: SEE NOTES

SCALE: N/A REV.: A0 UNIT: mm PAGE: 1/2

REV.	ECN NO.	CONTENT	DATE	ENGINEER
AO		Initial release		LYX

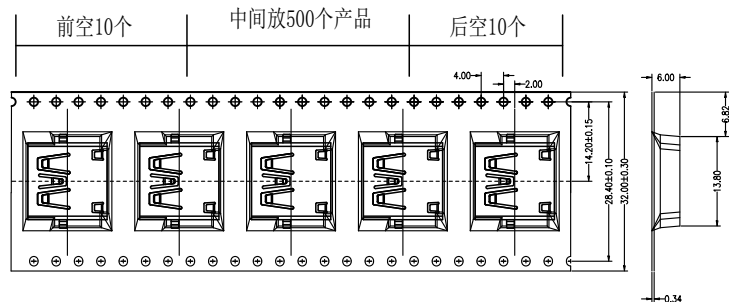

- 1: 材料: 透明PS料, 符合ROHS环境管理物质.
- 2: 所有尺寸符合EIA-481-B要求.
- 3: 厚度: $0.35 \pm 0.05\text{mm}$.
- 4: 使用 $\phi 330\text{mm}$ 胶盘, 包装零件数量: 500PCS/10.4M
- 5: 保护带: 透明PS材料.

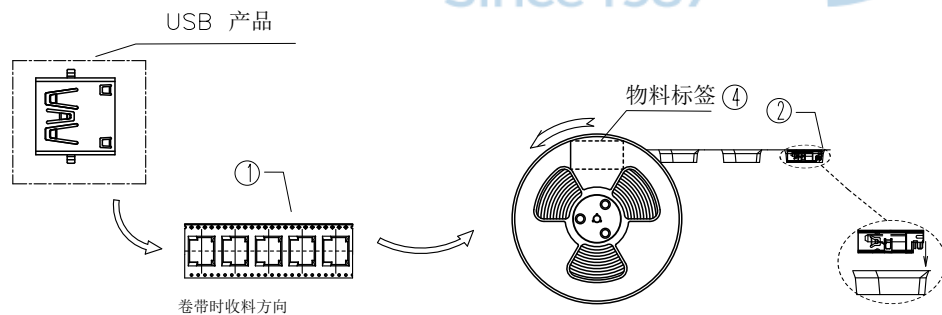

- 二:
- 1) 将机器调试好, 包装时前面先空10个空格, 中间放500个产品, 后面在空10个空格.
 - 2) 边放产品边用封胶带封口, 注意上带不可盖住下带孔. 1个卷盘放置500个产品, 并且中间不能有空格;
 - 3) 包完一卷后用皱纹胶纸粘好尾端, 然后在卷一圈保护带
 - 4) 每个卷盘上贴一张物料标签

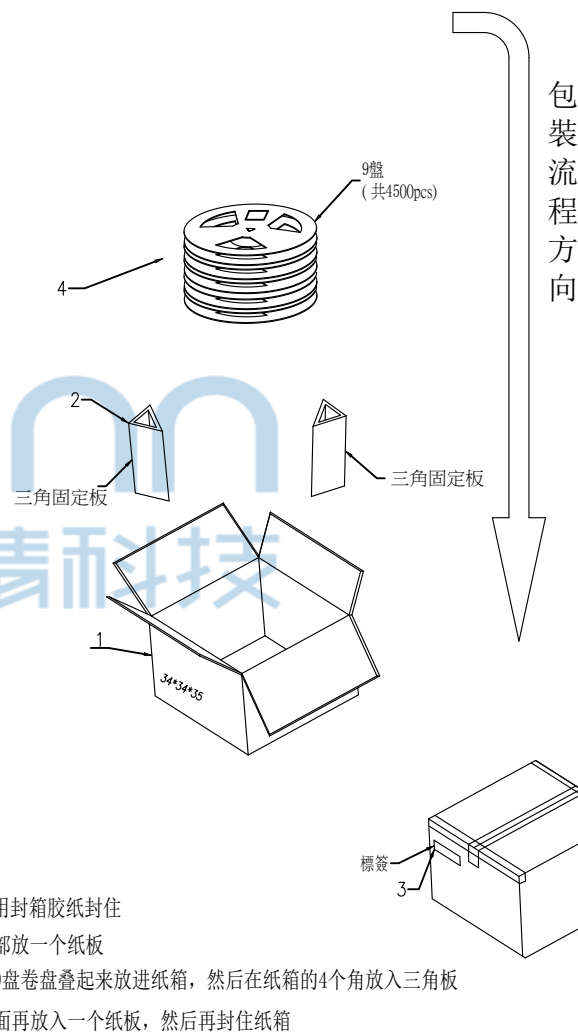

- 三:
- 1) 将纸箱底部用封箱胶纸封住
 - 2) 在纸箱的底部放一个纸板
 - 3) 将打包好的9盘卷盘叠起来放进纸箱, 然后在纸箱的4个角放入三角板
 - 4) 在纸箱的上面再放入一个纸板, 然后再封住纸箱



THIS DOCUMENT IS THE SOLE PROPERTY OF BBJconn Technology Co., Ltd. Corporation AND SHOULD NOT BE USED IN WHOLE OR IN PART WITHOUT PRIOR WRITTEN PERMISSION.		深圳市步步精科技有限公司	
PDWG.NO: 0471-1		NAME: USB 3.0 AF 四脚插 L=13.05 沉板2.86 端子DIP 端子镀金1u 平口 LCP蓝胶 不锈钢外壳 编带	
APPD.	JM_Zheng	PJ. NO.:	127-272-090032-Y4G
CHKD.	Yan	SIZE:	A4 DRW NO.:
DR.	LYX	FINISH:	SEE NOTES
		MAT'L.:	SEE NOTES
		SCALE:	N/A
		REV.:	AO
		UNIT:	mm
		PAGE:	2/2