

REV.	ECN NO	CONTENT	DATE	ENGINEER
A0		Initial release	/	TSP

- NOTE:
- MATERIAL:
 - INSULATOR: HIGH TEMPERATURE PLASTIC UL 94 V-0;
 - CONTACT: COPPER ALLOY(T=0.2mm)
 - SHELL: SUS201(T=0.30mm)
 - ELECTRICAL CHARACTERISTICS:
 - CONTACT RESISTANCE: 30m MAX.
 - CONTACT CURRENT RATING: 1.5A
 - DIELECTRIC WITHSTANDING VOLTAGE: 500 V R.M.S.
 - INSULATION RESISTANCE 100 MEGOHMS M
 - OPERATING TEMPERATURE: -55°C~85°C
 - RATE VOLTAGE: 30V DC
 - MECHANICAL CHARACTERISTICS:
 - MATING FORCE: 10 N Min INITIAL; 8 N Min AFTER TEST
 - UNMATED FORCE: 35 N Max
 - DURABILITY: 5,000 CYCLES
 - PLATING
 - TERMINAL CONTACT: GOLD PLATING ALL OVER
50u" MIN NICKEL AND 80u" MIN Matte Tin
NICKEL IN SOLDER AREA (SEE TAB)
 - SHELL: 50u" MIN. NICKEL ALL OVER



Pin #	SIGNAL NAME	DESCRIPTION	MATING SEQUENCE
1	VBUS	POWER	SECOND
2	D-	DIFFERENTIAL PAIR	THIRD
3	D+		
4	GND	GROUND FOR POWER RETURN	SECOND
5	StdA_SSRX-	SUPERSPEED RECEIVER DIFFERENTIAL PAIR	LAST
6	StdA_SSRX+		
7	GND_DRAIN	GROUND FOR SIGNAL RETURN	
8	StdA_SSTX-	SUPERSPEED TRANSMITTER DIFFERENTIAL PAIR	
9	StdA_SSTX+		
Shell	Shield	CONNECTOR METAL SHELL	FRIST



THIS DOCUMENT IS THE SOLE PROPERTY OF BBJconn Technology Co., Ltd. Corporation AND SHOULD NOT BE USED IN WHOLE OR IN PART WITHOUT PRIOR WRITTEN PERMISSION.

PDWG.NO: 0471-1

深圳市步步精科技有限公司

NAME: USB 3.0 AF 四脚插 端子DIP 端子镀金1U 反向沉板5.10 L=12.50 平口 LCP蓝胶 不锈钢外壳 编带

APPD. JM_Zheng

CHKD. LYX

DR. TSP

PJ. NO.: 127-272-090036-Y4G

SIZE: A4 DRW NO.:

FINISH: SEE NOTES MAT'L.: SEE NOTES

SCALE: N/A REV.: A0 UNIT: mm PAGE: 1/2



REV.	ECN NO	CONTENT	DATE	ENGINEER
A0		Initial release	/	TSP

38.4
32.4

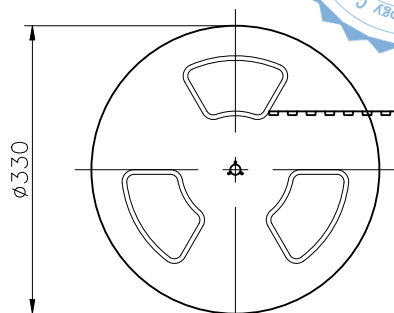

400 MIN. PEELING ANGLE 165° ~ 180°

ABOUT 160 MM LONG UNLOADED SECTION PRODUCT LOADING SECTION ABOUT 160 MM LONG UNLOADED SECTION

USER DIRECTION OF UNREELING

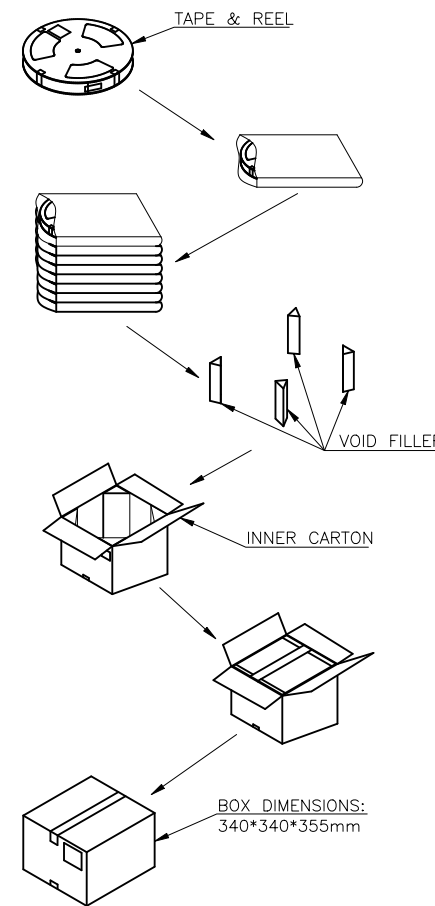
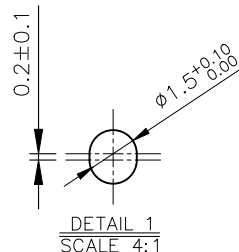
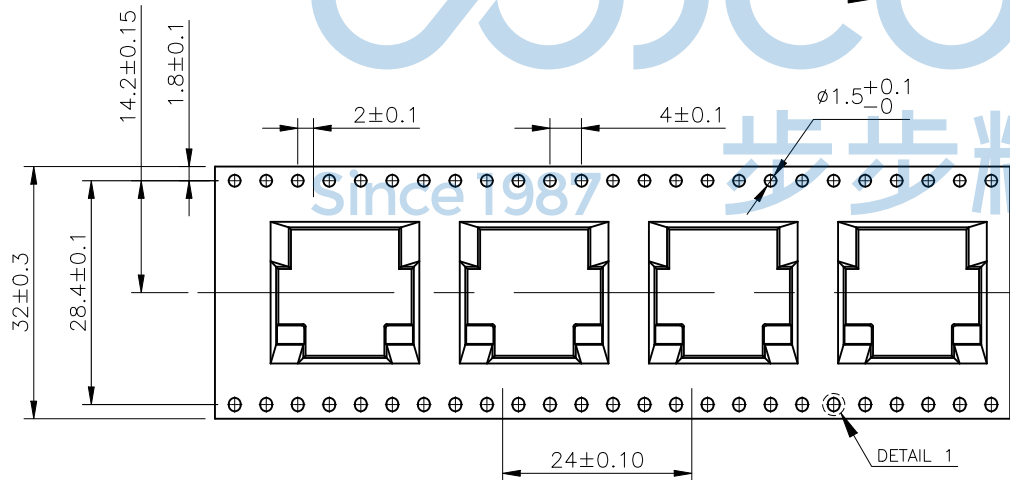

NOTE:

- MATERIAL:**
BOX: FIBREBOARD, CORRUGATED, DOUBLE WALL.
TAPE: POLYSTYRENES, HEAT-RESISTANT TEMPERATURE: 120°C, BLACK COLOR.
REEL: POLYSTYRENES, HEAT-RESISTANT TEMPERATURE: 70°C, BLUE COLOR.
BAG: POLYETHYLENE, HEAT-RESISTANT TEMPERATURE: 100°C.
- PEELING STRENGTH: 0.1 ~ 1.3 N (10 ~ 130 GRAMS)
- PEELING SPEED: 300 mm/min.
- EACH BAG SHALL BE INCLUDED DESICCANT.

450	9	4050 PCS	-- KG	-- KG
PCS/ REEL	REELS/ CARTON	QUANTITY	GROSS WEIGHT	NET WEIGHT

THIS DOCUMENT IS THE SOLE PROPERTY OF BBJconn Technology Co.,Ltd. Corporation AND SHOULD NOT BE USED IN WHOLE OR IN PART WITHOUT PRIOR WRITTEN PERMISSION.		深圳市步步精科技有限公司 .X: ±0.38 .X': ±3" .XX: ±0.25 .X'': ±2" .XXX: ±0.13 .X''': ±1"		NAME: USB 3.0 AF 四脚插 端子DIP 端子镀金1U 反向沉板5.10 L=12.50 平口 LCP蓝胶 不锈钢外壳 编带 PJ. NO.: 127-272-090036-Y4G SIZE: A4 DRW NO.: FINISH: SEE NOTES MAT'L.: SEE NOTES SCALE: N/A REV.: A0 UNIT: mm PAGE: 2/2	
APPD.	JM_Zheng	CHKD.	LYX	DR.	TSP
PDWG.NO:	0471-1				