

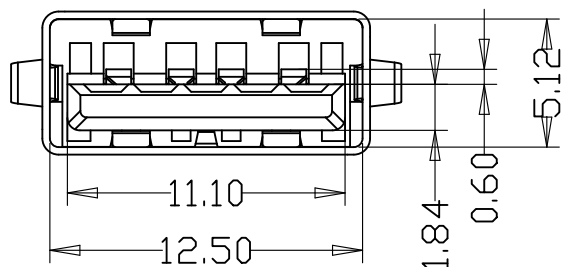

REV.	ECN NO	CONTENT	DATE	ENGINEER
A0		Initial release	/	TSP

NOTE:

1. MATERIAL:
 - 1.1 INSULATOR:PBT & PA9T &LCP
 - 1.2 CONTACT:COPPER ALLOY
 - 1.3 SHELL:BRASS&SPCC&SUS201
2. ELECTRICAL CHARACTERISTICS:
 - 2.1 CONTACTRESISTANCE:40mΩ MAXIMUM
 - 2.2 CONTACT CURRENT RATING:1.5A
 - 2.3 DIELECTRIC WITHSTANDING VOLTAGE:100 V R. M. S.
 - 2.4 INSULATION RESISTANCE 100 MEGOHMS MIN
 - 2.5 OPERATING TEMPERATURE:-20° C ~ 60° C
3. PLATING
 - 3.1 TERMINAL:
 - 50u" MIN NICKEL ALL OVER
 - 100u"MIN Tin ON SOLDER AREA
 - (1~30)u"Au ON CONTACT AREA
 - 3.2 SHELL:80u"MIN.NICEL ALL OVER

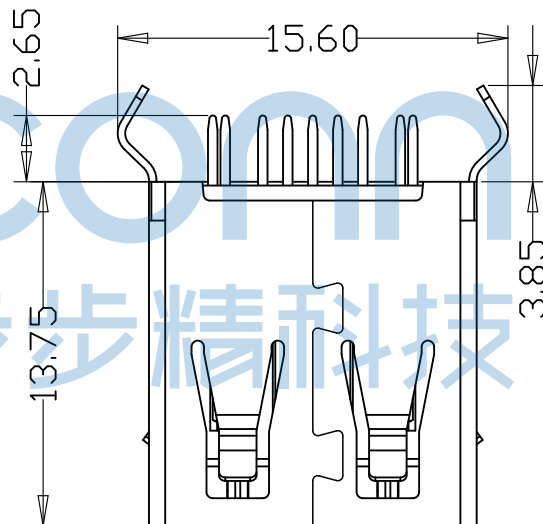
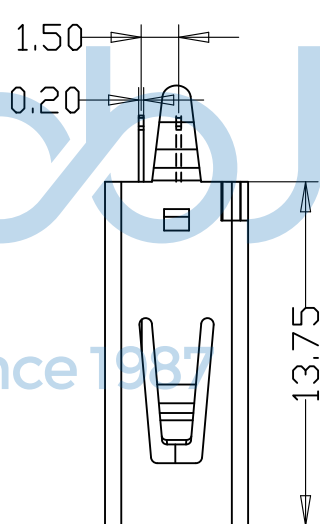
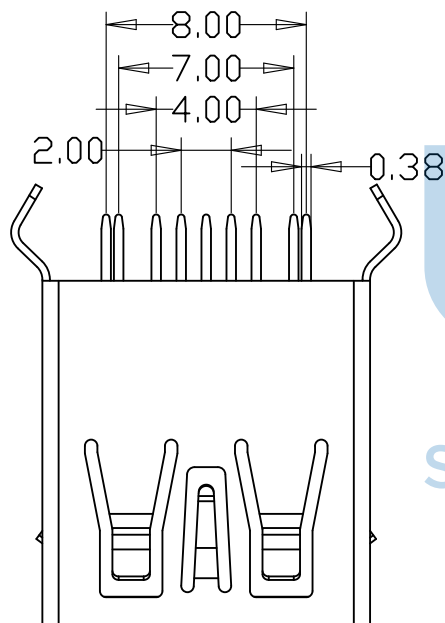
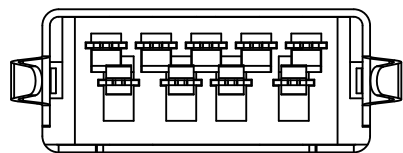

Pin NUMBER	SIGNAL NAME
1	VBUS
2	D-
3	D+
4	GND
5	StdA_SSRX-
6	StdA_SSRX+
7	GND_DRAIN
8	StdA_SSTX-
9	StdA_SSTX+
Shell	Shield

THIS DOCUMENT IS THE SOLE PROPERTY OF BBJconn Technology Co.,Ltd. Corporation AND SHOULD NOT BE USED IN WHOLE OR IN PART WITHOUT PRIOR WRITTEN PERMISSION.		深圳市步步精科技有限公司 工程管理部	
PDWG.NO: 0471-1	DR. TSP	.X: ±0.38 .XX: ±0.25 .XXX: ±0.13 X': ±3' .X': ±2' .XX': ±1'	NAME: USB 3.0 AF 180度 弯脚 H=13.75 LCP蓝胶 铜壳 平口 DIP APPD. JM_Zheng CHKD. LYX PJ. NO.: 127-275-090009-Y4G SIZE: A4 DRW NO.: FINISH: SEE NOTES MAT'L.: SEE NOTES SCALE: N/A REV.: A0 UNIT: mm PAGE: 1/2

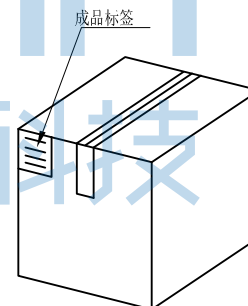
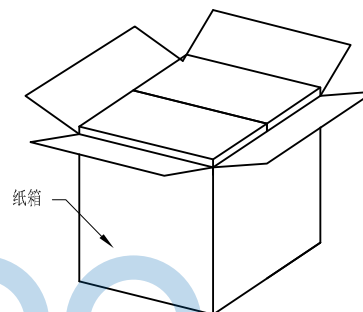
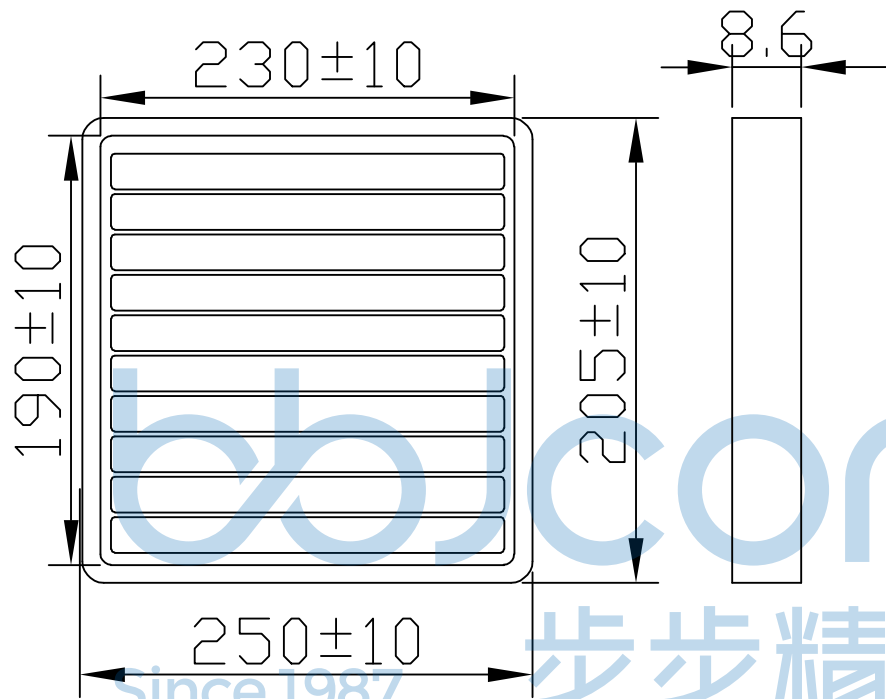

纸箱规格: 350*210*290

1. 包装要求:
- 1.1 每盒吸塑盒包装100pcs;
- 1.2 每20盘放一箱, 共计2000PCS;
- 1.3 纸箱外贴上标签。

THIS DOCUMENT IS THE SOLE PROPERTY OF BBJconn Technology Co.,Ltd. Corporation AND SHOULD NOT BE USED IN WHOLE OR IN PART WITHOUT PRIOR WRITTEN PERMISSION.		深圳市步步精科技有限公司	
.X: ±0.38 .XX: ±0.25 .XXX: ±0.13		X*: ±3* .X*: ±2* .XX*: ±1*	
APPD. JM_Zheng		NAME: USB 3.0 AF 180度 弯脚 H=13.75 LCP蓝胶 铜壳 平口 DIP	
CHKD. LYX		PJ. NO.: 127-275-090009-Y4G	
DR. TSP		SIZE: A4 DRW NO.:	
PDWG.NO: 0471-1		FINISH: SEE NOTES MAT'L.: SEE NOTES	
		SCALE: N/A REV.: A0 UNIT: mm PAGE: 2/2	