

REV.	ECN NO.	CONTENT	DATE	ENGINEER
A0				

规格说明:Specifications:
电气特性:Electrical:

1. 额定电流: Current Rating
1.5A/contact terminal
2. 额定电压: Voltage Rating
30V DC
3. 接触阻抗: Contact Resistance
30 milliohms MAX
4. 耐电压: Dielectric Withstanding Voltage:
500 V AC AT Sea Level
5. 绝缘阻抗: Insulation Resistance:
1000MEGA ohms MIN

1. 插拔力: Connector Mate and Unmate Force
Mate force: 3.57kgf (MAX)
Unmate force: 1.02kgf (MIN)
2. 端子保持力: Terminal Retention
1.0kgf (MIN)

1. 塑胶: Housing:
Hing Temperature Thermoplastics, LCP
2. 端子: Contact: Copper Alloy C2680
3. 外壳: Shell: Copper Alloy SUS201

电镀: Finish:

1. 端子: Contact: Plated Gold in Mating Area;
Tin On Solder Tails
端子四周镀50U" (MIN) 锡, 镀金区域镀100-200U" 镀金1U"
2. 外壳: Shell:
铜壳四周镀80U" (MIN) 锡
Nickel Plating

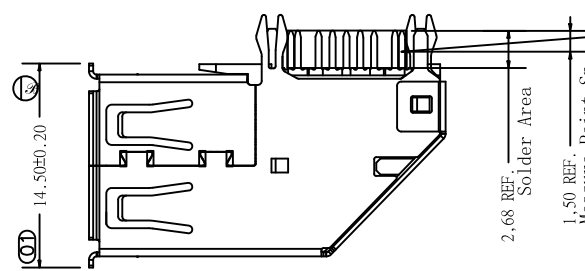
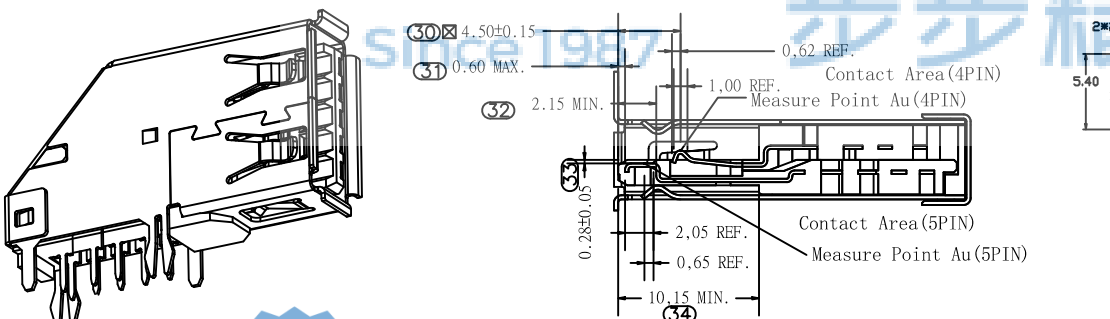
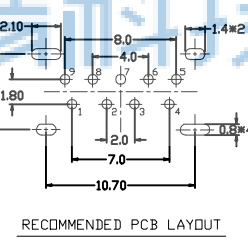
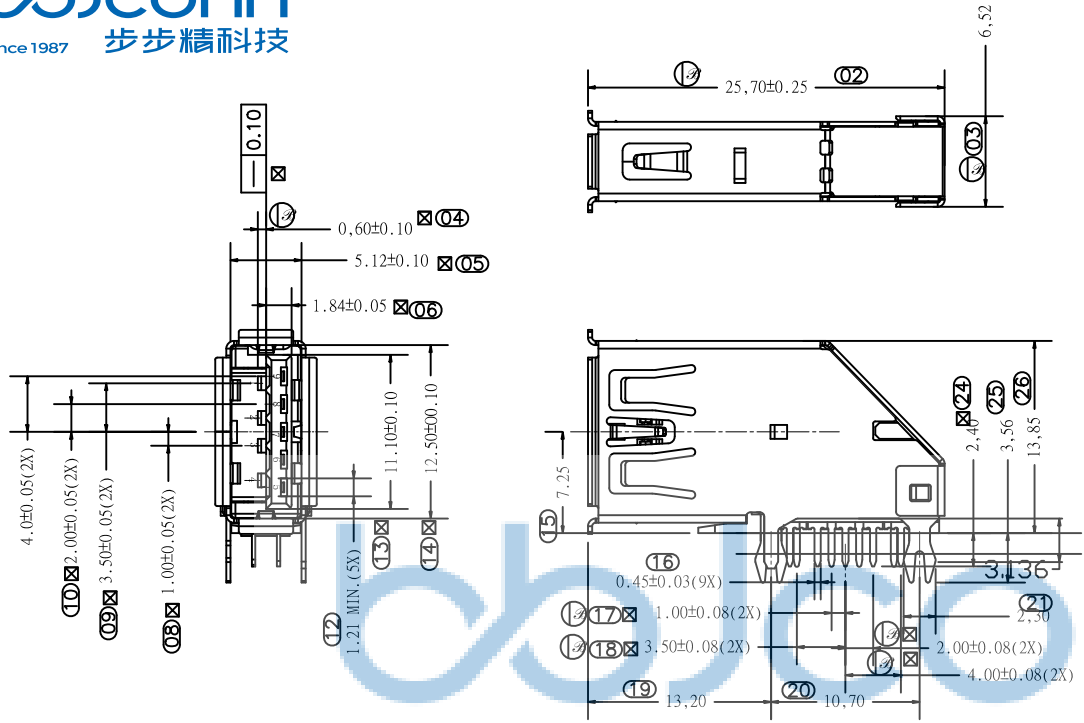

THIS DOCUMENT IS THE SOLE PROPERTY OF BBJconn Technology Co., Ltd. CORPORATION AND SHOULD NOT BE USED IN WHOLE OR IN PART WITHOUT PRIOR WRITTEN PERMISSION.		深圳市步步精科技有限公司	
.X: ±0.38 .XX: ±0.25 .XXX: ±0.13		X': ±3' X'': ±2' .XX': ±1'	
APPD. JM_Zheng	NAME: USB 3.0 AF 90度 侧插 端子DIP L=25.70 鱼叉脚 卷边 LCP蓝胶 不锈钢外壳 端子接触区镀金15u	PJ. NO.: 127-278-090001-Y4G SIZE: A4 DRW NO.:	
CHKD. TSP	FINISH: SEE NOTES	MAT'L.: SEE NOTES	
PDWG.NO: 0471-1	DR. LYX	SCALE: N/A	REV.: A3 UNIT: mm PAGE: 1/2

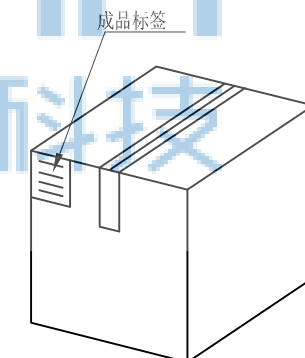
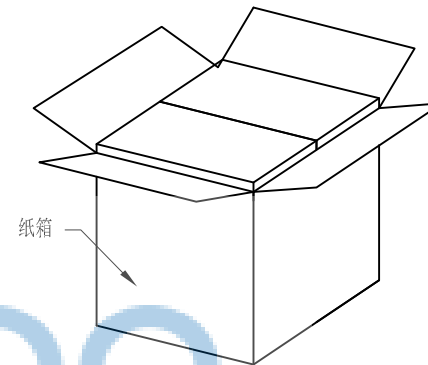
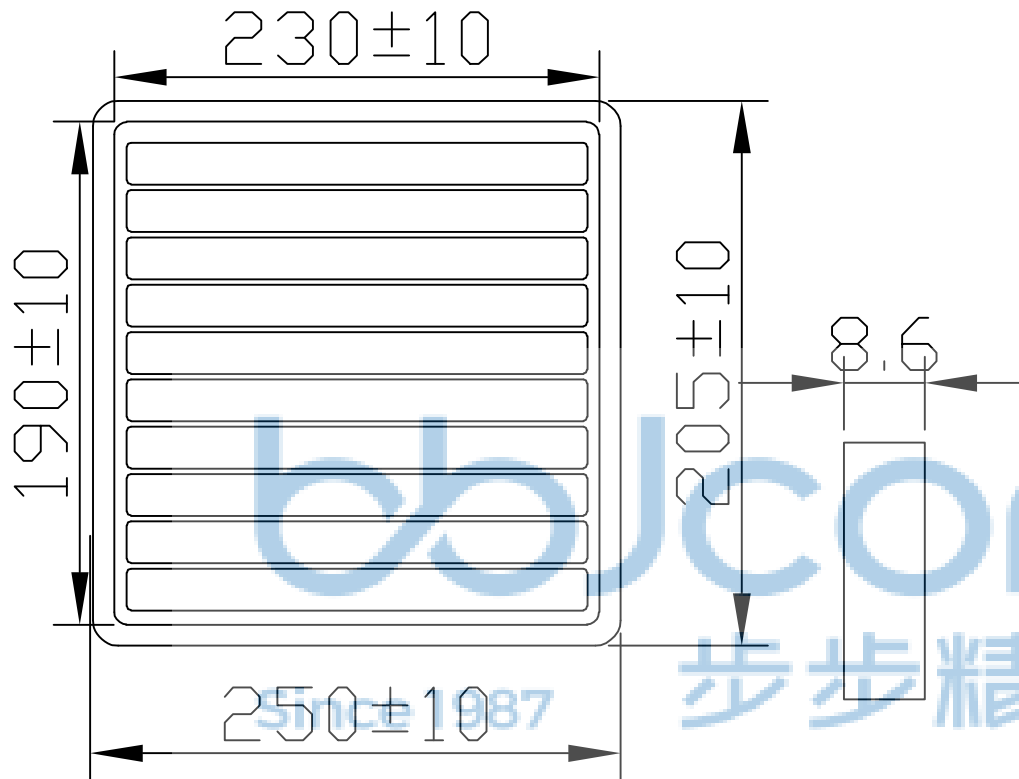

纸箱规格：350*210*290

1. 包装要求:
- 1.1 每盒吸塑盒包装100PCS;
 - 1.2 每20盘放一箱，共计2000PCS;
 - 1.3 纸箱外贴上标签

THIS DOCUMENT IS THE SOLE PROPERTY OF BBJconn Technology Co.,Ltd Corporation AND SHOULD NOT BE USED IN WHOLE OR IN PART WITHOUT PRIOR WRITTEN PERMISSION. PDWG.NO: 0471-1	深圳市步步精科技有限公司		NAME: USB 3.0 AF 90度 侧插 端子DIP L=25.70 鱼叉脚 卷边 LCP蓝胶 不锈钢外壳 端子接触区镀金15u	
	.X: ±0.38	X': ±3'	PJ. NO.: 127-278-090001-Y4G	SIZE: A4 DRW NO.:
	.XX: ±0.25	.X': ±2'		
	.XXX: ±0.13	.XX': ±1'	FINISH: SEE NOTES	MAT'L.: SEE NOTES
	APPD. JM_Zheng	CHKD. TSP	SCALE: N/A	REV.: A3
DR. LYX				PAGE: 2/2