

REV.	ECN NO	CONTENT	DATE	ENGINEER
A0		Initial release	2022.05.17	TSP
A1	EN2310001	由吸塑包装100/盘, 更改为载带包装350/卷	2023.10.09	TSP
A2				
A3				

NOTE:

1. MATERIAL:

- 1.1 INSULATOR:HIGH TEMPERATURE PLASTIC
- 1.2 CONTACT:BRONZE,
- 1.3 SHELL: SPCC (T=0.30mm)

2. ELECTRICAL CHARACTERISTICS:

- 2.1 CONTACT RESISTANCE:30mΩ MAXIMUM
- 2.2 CONTACT CURRENT RATING:1.5A
- 2.3 DIELECTRIC WITHSTANDING VOLTAGE:100 V AC R. M. S.
- 2.4 INSULATION RESISTANCE 100 MEGOHMS MIN
- 2.5 OPERATING TEMPERATURE:-40° C ~ 85° C

3 MECHANICAL CHARACTERISTICS:

- 3.1 MATING FORCE:3.57kgf MAX
- 3.2 UNMATED FORCE:0.82kgf MIN AFTER TEST
- 3.3 DURABILITY MANDATORY:1,500 CYCLES
- 3.4 Salt Spray: 24 hours

4. PLATING

- 4.1 TERMINAL:  
50u" NICKEL ALL OVER  
80u" Tin ON SOLDER AREA  
(1~30)u"Au ON CONTACT AREA
- 4.2 SHELL:50u"NICEL ALL OVER

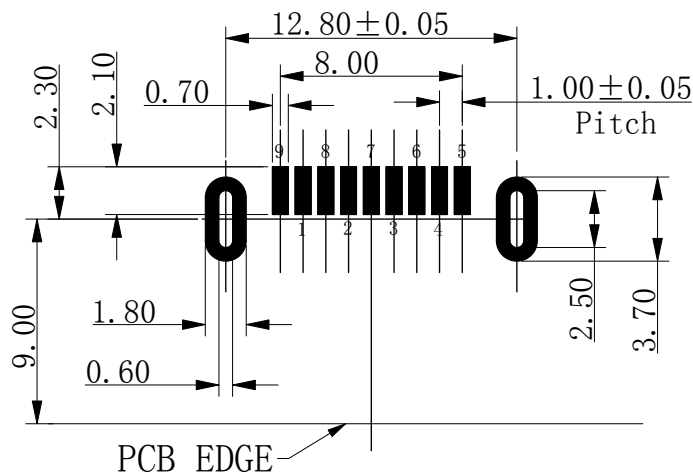

RECOMMENDED PCB LAYOUT  
TOLERANCES: ±0.05

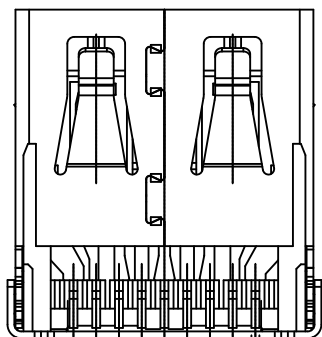
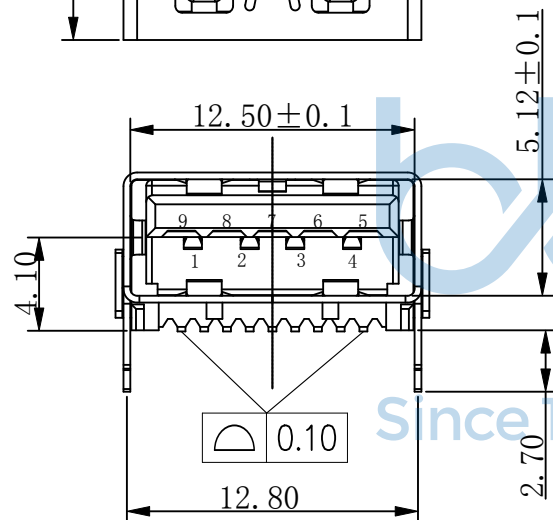
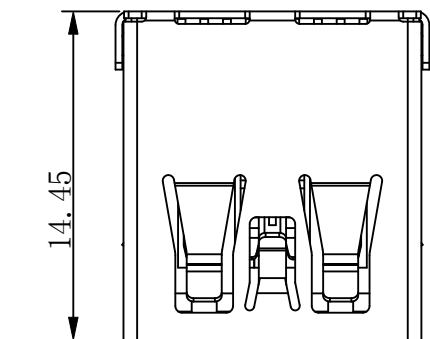
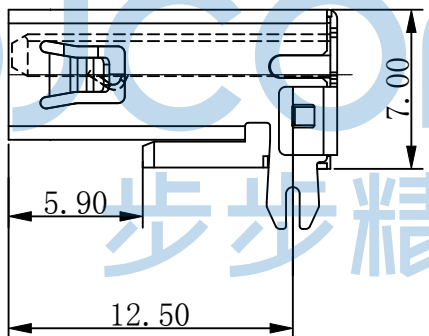

3	SHELL	1	SPCC
2	TERMINAL	9	BRONZE
1	Molding-ASSY	1	LCP
NO.	TITLE	Q'TY	MATERIAL

THIS DOCUMENT IS THE  
SOLE PROPERTY OF  
BBJconn Technology Co.,Ltd.  
Corporation AND SHOULD  
NOT BE USED IN WHOLE  
OR IN PART WITHOUT  
PRIOR WRITTEN PERMISSION.

**深圳市步步精科技有限公司**

.X: ±0.38 X\*: ±3\*  
.XX: ±0.25 .X\*: ±2\*  
.XXX: ±0.13 .XX\*: ±1\*

NAME: USB 3.0 AF 90度 L=14.45 后两脚直插 鱼叉脚  
端子SMT 平口 LCP蓝胶 铁壳 编带

APPD. JM\_Zheng

PJ. NO.: 127-271-090001-0G

CHKD. LYX

SIZE: A4 DRW NO.:

PDWG.NO: 0471-1

FINISH: SEE NOTES MAT'L.: SEE NOTES

DR. TSP

SCALE: N/A REV.: A1 UNIT: mm PAGE: 1/2

REV.	ECN NO	CONTENT	DATE	ENGINEER
A0		Initial release	2022.05.17	TSP
A1	EN2310001	由吸塑包装100/盘, 更改为载带包装350/卷	2023.10.09	TSP
A2				
A3				

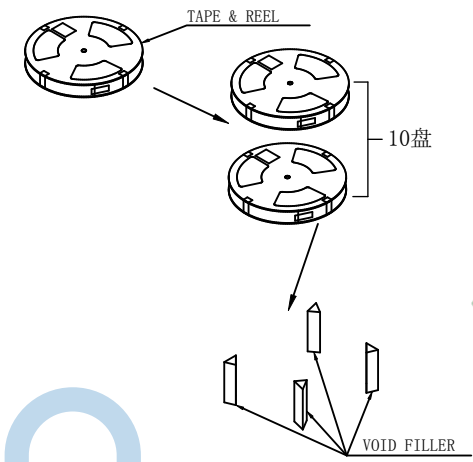
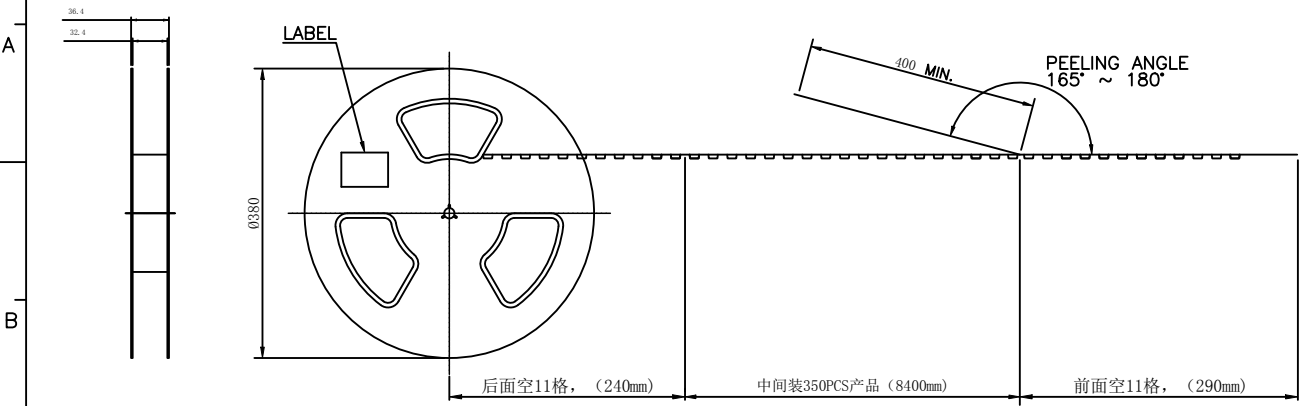

USER DIRECTION OF UNREELING →

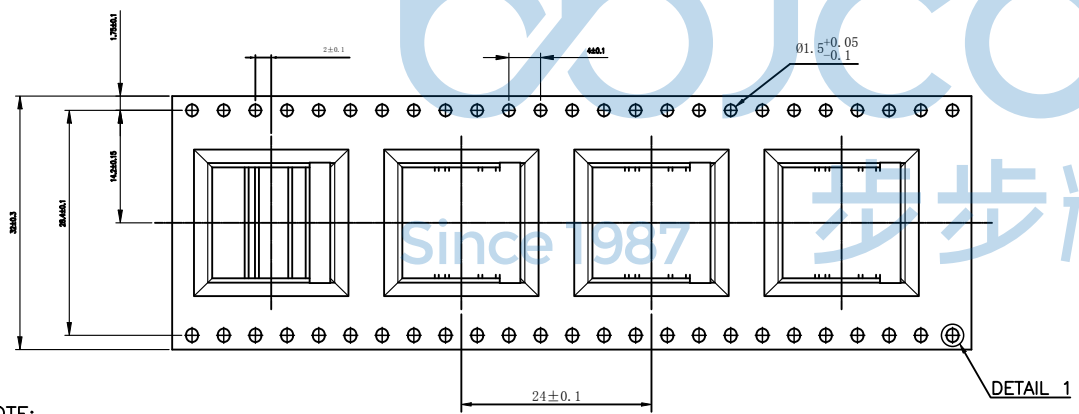

BOX DIMENSIONS: 400 X 400 X 400

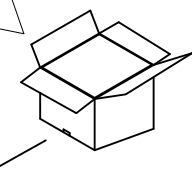
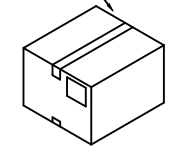

- NOTE:
- MATERIAL:  
BOX: FIBREBOARD, CORRUGATED, DOUBLE WALL.  
TAPE: POLYSTYRENES, HEAT-RESISTANT TEMPERATURE: 120°C, BLACK COLOR.  
REEL: POLYSTYRENES, HEAT-RESISTANT TEMPERATURE: 70°C, BLUE COLOR.  
BAG: POLYETHYLENE, HEAT-RESISTANT TEMPERATURE: 100°C.
  - PEELING STRENGTH: 0.1 ~ 1.3 N (10 ~ 130 GRAMS)
  - PEELING SPEED: 300 mm/min.
  - EACH BAG SHALL BE INCLUDED DESICCANT.



350	10	3500 PCS	-- KG	-- KG
PCS/盘	盘/箱	PCS/箱	GROSS WEIGHT	NET WEIGHT

THIS DOCUMENT IS THE SOLE PROPERTY OF BBJconn Technology Co., Ltd. Corporation AND SHOULD NOT BE USED IN WHOLE OR IN PART WITHOUT PRIOR WRITTEN PERMISSION.

PDWG.NO: 0471-1

DR. TSP

APPD. JM\_Zheng

CHKD. LYX

NAME: USB 3.0 AF 90度 L=14.45 后两脚直插 鱼叉脚 端子SMT 平口 LCP蓝胶 铁壳 带带

PJ. NO.: 127-271-090001-0G

SIZE: A4 | DRW NO.:

FINISH: SEE NOTES | MAT'L.: SEE NOTES

SCALE: N/A | REV.: A1 | UNIT: mm | PAGE: 2/2

**深圳市步步精科技有限公司**