

REV.	ECN NO	CONTENT	DATE	ENGINEER
A0		Initial release	/	TSP

NOIES.
 1.MATERIAL:
 1-1 HOUSING: PA9T, UL 94V-0, COLOR:
 1-2 TERMINAL: C5191 ,T=0.25
 1-3 TERMINAL: C2680 ,T=0.25
 1-4 SHELL:STAINLESS STEEL , T=0.30
 1-5 CAP:LCP UL 94V-0, COLOR:
 2.PLATING:
 2-1 TERMINAL:
 GOLD PLATED G/F ON CONTACT AREA
 AND 2.03 μ m [80 μ "] MIN. MATTE-TIN ON SOLDER TAIL,
 WITH ENTIRE CONTACT UNDERPLATED 1.27 μ m[50 μ "] MIN.NICKEL.
 2-2 SHELL:1.27 μ m [50 μ "] MIN. NICKEL PLATED.
 3.MECHANICAL CHARACTERISTICS:
 3-1 INSERTION FORCE:35N (3.57 Kg) MAX.
 3-2 EXTRACTION FORCE:INITIAL:10N~25N; AFTER:8N~25N.
 3-3 DURABILITY: 5000 CYCLES.

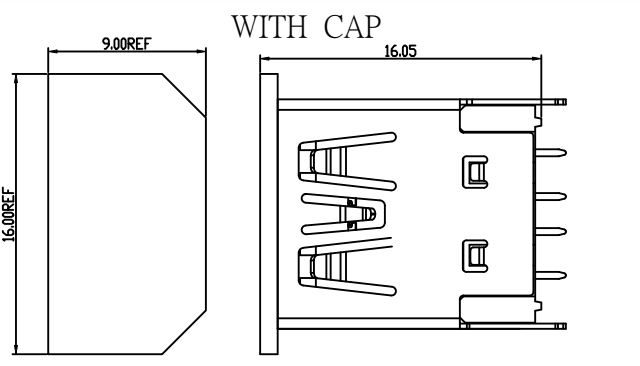
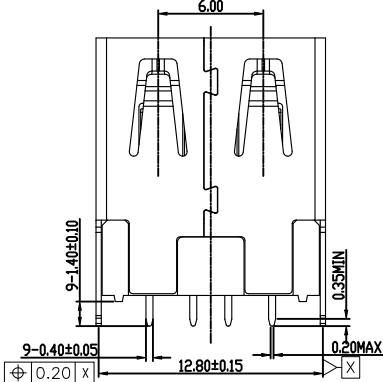
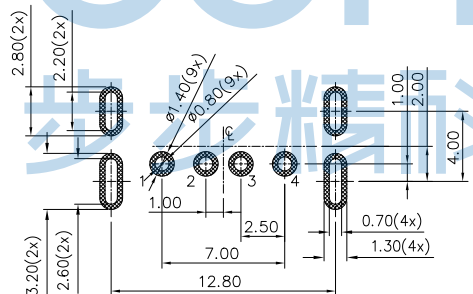
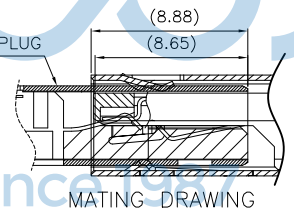
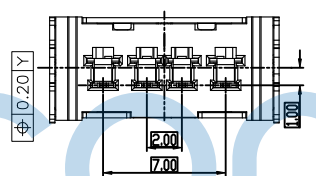
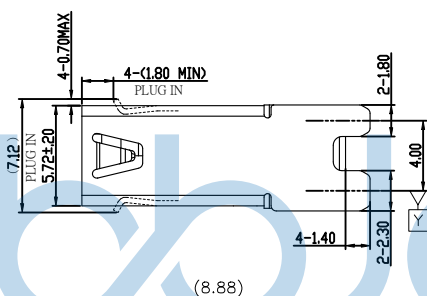
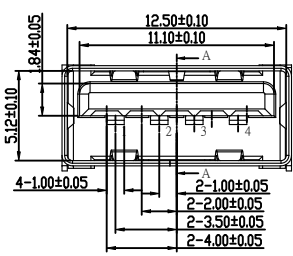
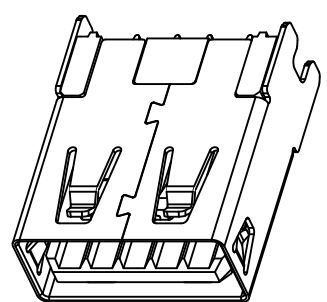
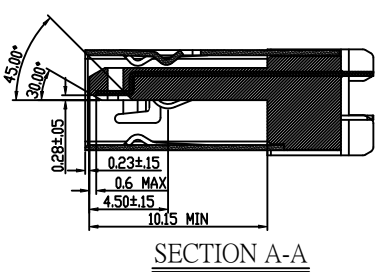
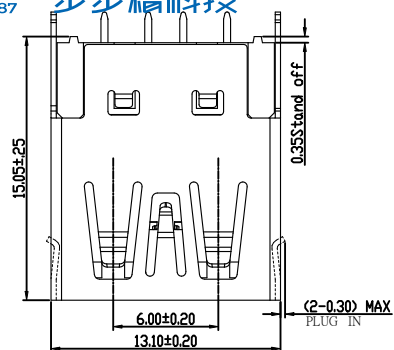

CONTACTS: GOLD	Pin #	SIGNAL NAME
CONTACTS PLATING THICKNESS:G/F~30U" Au	1	VBUS
SOLDERING PLATING: MATTE-TIN	2	D-
SHELL PLATING: NICKEL	3	D+
	4	GND
	5	StdA_SSRX-
	6	StdA_SSRX+
	7	GND_DRAIN
	8	StdA_SSTX-
	9	StdA_SSTX+
	Shell	Shield

THIS DOCUMENT IS THE SOLE PROPERTY OF BBJconn Technology Co.,Ltd. Corporation AND SHOULD NOT BE USED IN WHOLE OR IN PART WITHOUT PRIOR WRITTEN PERMISSION. PDWNG:NO: 0886-1	深圳市步步精科技有限公司 APPROVED 工程 部	深圳市步步精科技有限公司	
		NAME: USB 2.0 A母 180度 DIP 四脚插 平口 不锈钢外壳 PA9T蓝胶 锡脚1.40 H=15.05 加盖编带	PJ. NO.: 127-275-040002-K4G SIZE: A4 DRW NO.: FINISH: SEE NOTES MAT'L.: SEE NOTES SCALE: N/A REV.: A0 UNIT: mm PAGE: 1/2

REV.	ECN NO	CONTENT	DATE	ENGINEER
A0		Initial release	/	TSP

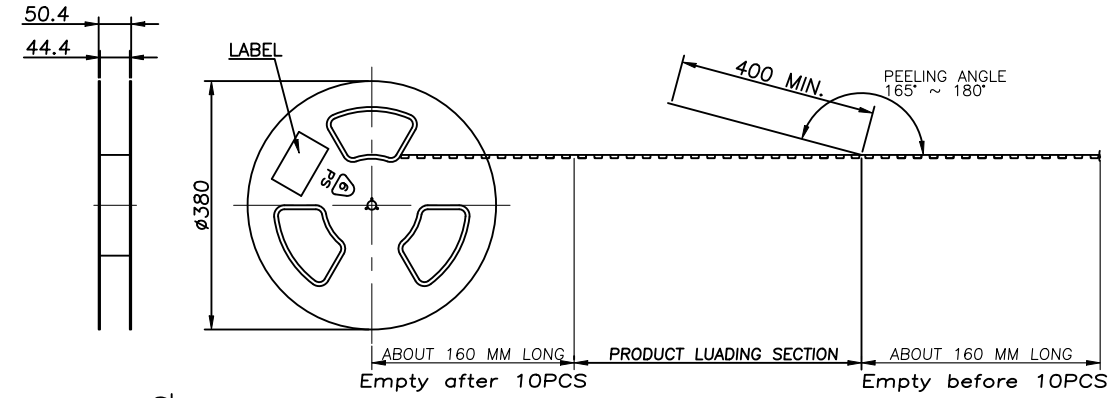

- NOTE:
- MATERIAL:
BOX: FIBREBOARD, CORRUGATED, DOUBLE WALL.
TAPE: POLYSTYRENES, HEAT-RESISTANT TEMPERATURE: 120°C, Transparent COLOR.
REEL: POLYSTYRENES, HEAT-RESISTANT TEMPERATURE: 70°C, BLUE COLOR.
BAG: POLYETHYLENE, HEAT-RESISTANT TEMPERATURE: 100°C.
 - PEELING STRENGTH: 0.1 ~ 1.3 N (10 ~ 130 GRAMS)
 - PEELING SPEED: 300 mm/min.
 - EACH BAG SHALL BE INCLUDED DESICCANT.

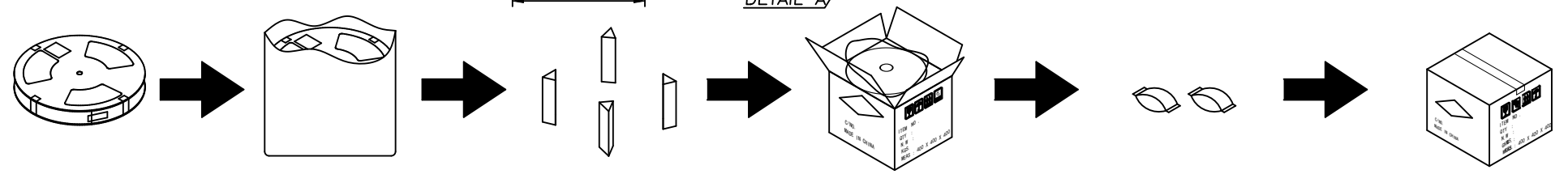
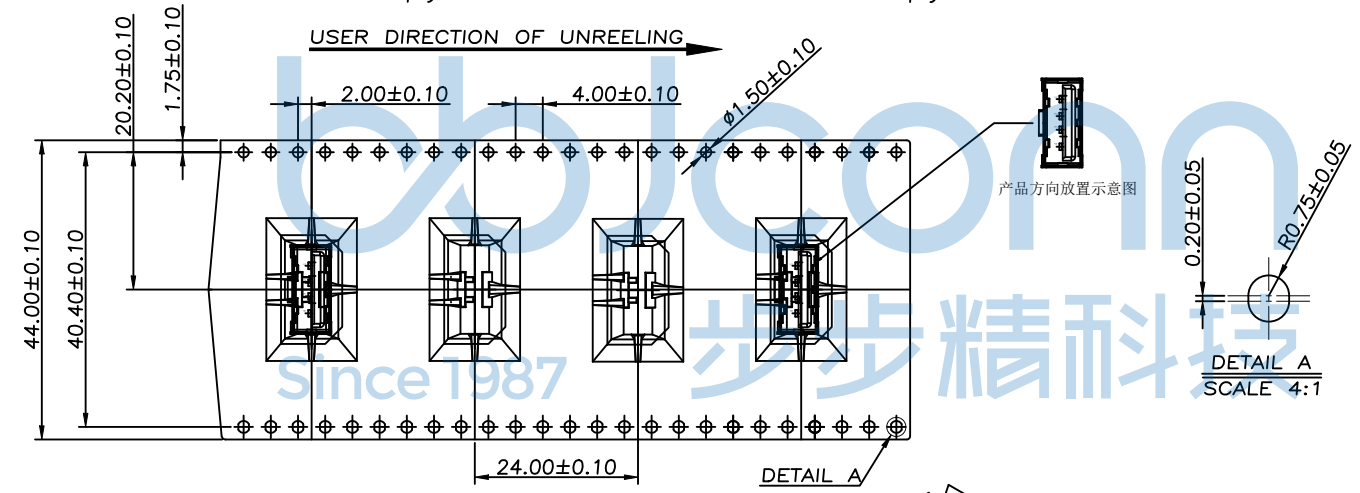

Each reels contains 180 PCS Each bag contains 8 reels Put 4PCS corner protector in each box Put 8PCS rolls in each box Put 2PCS desiccant in each box Box dimensions:400 X 400 X 400

180 PCS	8 R	1440 PCS	-- KG	-- KG
PSC/Reel	Reel/CARTON	QUANTITY	CROSS WEIGHT	NET WEIGHT

THIS DOCUMENT IS THE SOLE PROPERTY OF BBJconn Technology Co.,Ltd. Corporation AND SHOULD NOT BE USED IN WHOLE OR IN PART WITHOUT PRIOR WRITTEN PERMISSION.

PDWG.NO: 0886-1

深圳市步步精科技有限公司

.X: ±0.38	X': ±3'	NAME:	USB 2.0 A母 180度 DIP 四脚插 平口 不锈钢外壳 PA9T蓝胶 锡脚1.40 H=15.05 加盖编带
.XX: ±0.25	.X': ±2'	APPD.	JM_Zheng
.XXX: ±0.13	.XX': ±1'	CHKD.	LYX
		DR.	TSP

PJ. NO.: 127-275-040002-K4G
SIZE: A4 | DRW NO.:
FINISH: SEE NOTES MAT'L.: SEE NOTES
SCALE: N/A REV.: A0 UNIT: mm PAGE: 2/2