

REV.	ECN NO	CONTENT	DATE	ENGINEER
A0		Initial release	/	TSP

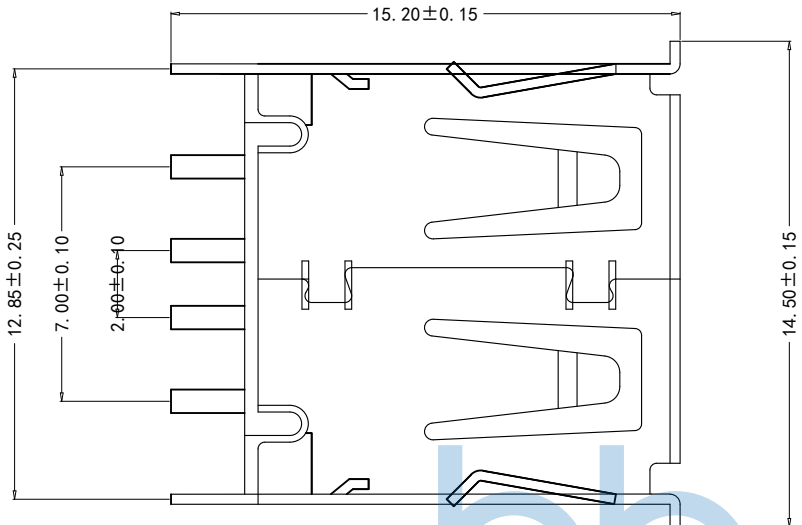

- 备注:
- 材质:
 - 1-1 塑胶: LCP/PBT
 - 1-2 端子: 黄铜C2680
 - 1-3 外壳: BRASS/SPCC
 - 电镀:
 - 端子接触区域: 镀金G/F
 - 端子锡脚: 镀锡80u"min.
 - 端子整个表面: 镀镍40u"min.
 - 铁壳: 镀镍30u"min
 - 电气性能:
 - 3-1 耐电压: 500V 交流电
 - 3-2 接触电阻: 30 毫欧 最大
 - 3-3 绝缘阻抗: 1000 兆欧最小
 - 机械性能:
 - 4-1 插入力: 3.57kgf MAX
 - 4-2 拨出力: 1.02kgf MIN
 - 环境:
 - 温度范围: -55° C TO +85° C
 - 电镀 Finish:
 - 端子: Contact:Plated Gold in Mating Area; Tin/on Solder Tails
 - 接触点镀金 脚镀锡
 - 外壳: Shell: Nickel Plating 镀镍

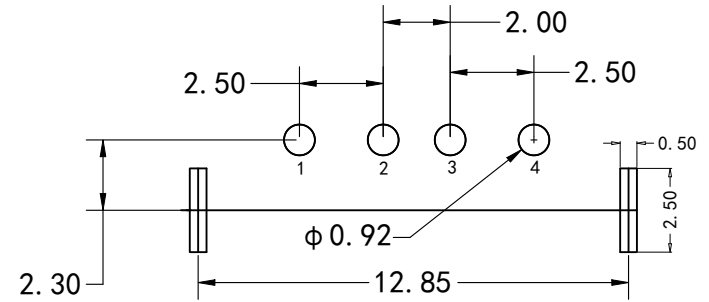
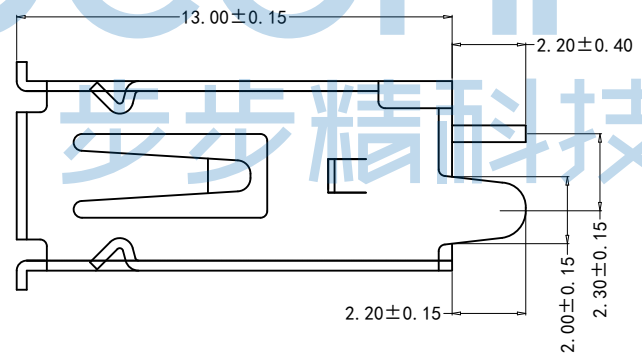
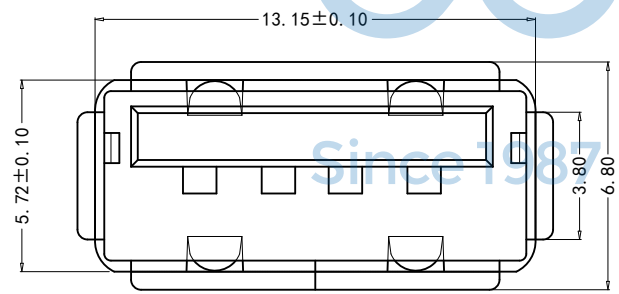

Recommended P.C.B Layout (±0.05)

THIS DOCUMENT IS THE SOLE PROPERTY OF BBJconn Technology Co.,Ltd. Corporation AND SHOULD NOT BE USED IN WHOLE OR IN PART WITHOUT PRIOR WRITTEN PERMISSION.		深圳市步步精科技有限公司 .X: ±0.38 .XX: ±0.25 .XXX: ±0.13 X*: ±3" .X*: ±2" .XX*: ±1"		NAME: USB 2.0 AF 180度 直插直脚 H=13.0 端子DIP 卷边 LCP黑胶 铁壳 P脚和插脚长2.2mm 加盖编带 APPD. JM_Zheng CHKD. LYX DR. TSP	
PDWG.NO: 0383-1		PJ. NO.: UB.01.11-11-V010 SIZE: A4 DRW NO.: FINISH: SEE NOTES MAT'L.: SEE NOTES SCALE: N/A REV.: A0 UNIT: mm PAGE: 1/2			

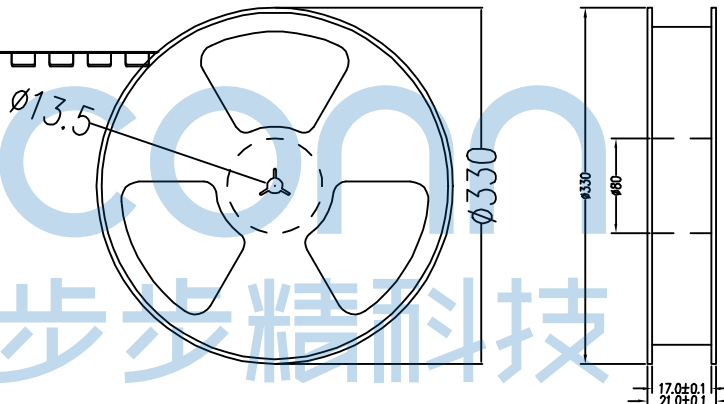
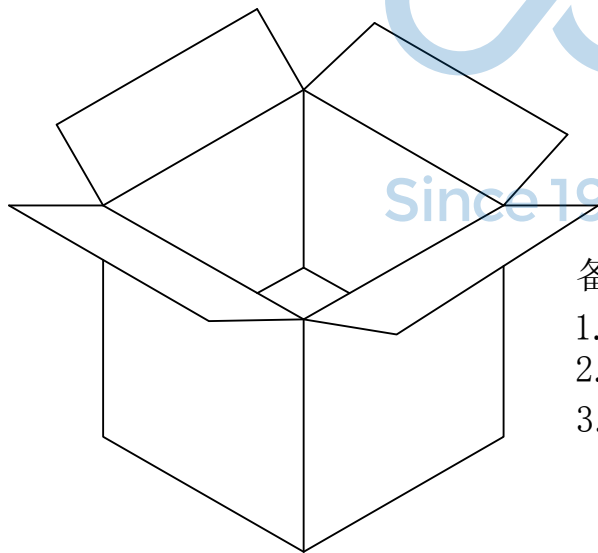
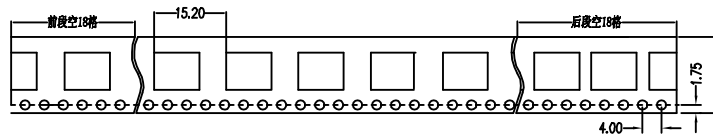
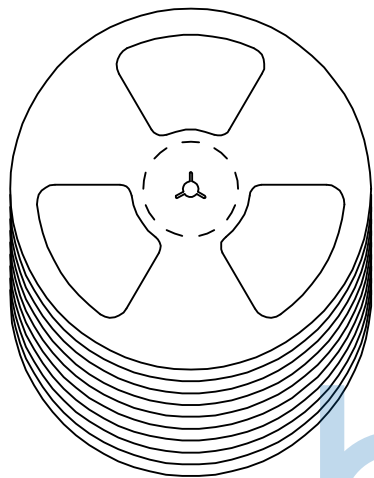

备注:

1. 包装数量: 300/PCS/卷, 10卷/箱。
2. 包装袋长度: 每卷前后各空10-20个空格, 中间包装。
3. 材质:
载体: 聚丙烯 (PS),
上带: 聚乙烯 (PET),
卷盘: 聚苯乙烯。

纸箱规格: 345*345*23MM

纸箱规格: 345*345*35MM

THIS DOCUMENT IS THE SOLE PROPERTY OF BBJconn Technology Co.,Ltd. Corporation AND SHOULD NOT BE USED IN WHOLE OR IN PART WITHOUT PRIOR WRITTEN PERMISSION.		深圳市步步精科技有限公司	
.X: ±0.38 .XX: ±0.25 .XXX: ±0.13		X': ±3" X'': ±2" XX': ±1"	
APPD.	JM_Zheng	NAME: USB 2.0 AF 180度 直插直脚 H=13.0 端子DIP 卷边 LCP黑胶 铁壳 P脚和插脚长2.2mm 加盖编带	
CHKD.	LYX	PJ. NO.: UB.01.11-11-V010	
DR.	TSP	SIZE: A4 DRW NO.:	
PDWG.NO:	0383-1	FINISH: SEE NOTES MAT'L.: SEE NOTES	
		SCALE: N/A REV.: A0 UNIT: mm PAGE: 2/2	